

# GREAT DESIGNS IN **STEEL**

## **Exploring the Latest Lightweight Design: STAF (Steel Tube Air Forming)**

Ryuichi Funada

Sumitomo Heavy Industries, USA Inc.

Specialist of Sales Engineering

- 1 . Introduction of STAF
- 2 . Positioning of STAF
- 3 . STAF's advantages
- 4 . Case study I & II
- 5 . STAF's application

- 1 . Introduction of STAF
- 2 . Positioning of STAF
- 3 . STAF's advantages
- 4 . Case study I & II
- 5 . STAF's application

# 1. Introduction of STAF

- Form **high strength and high rigidity** auto parts in one-pack.
- Form flanges, **drastically the assembly processes are reduced.**

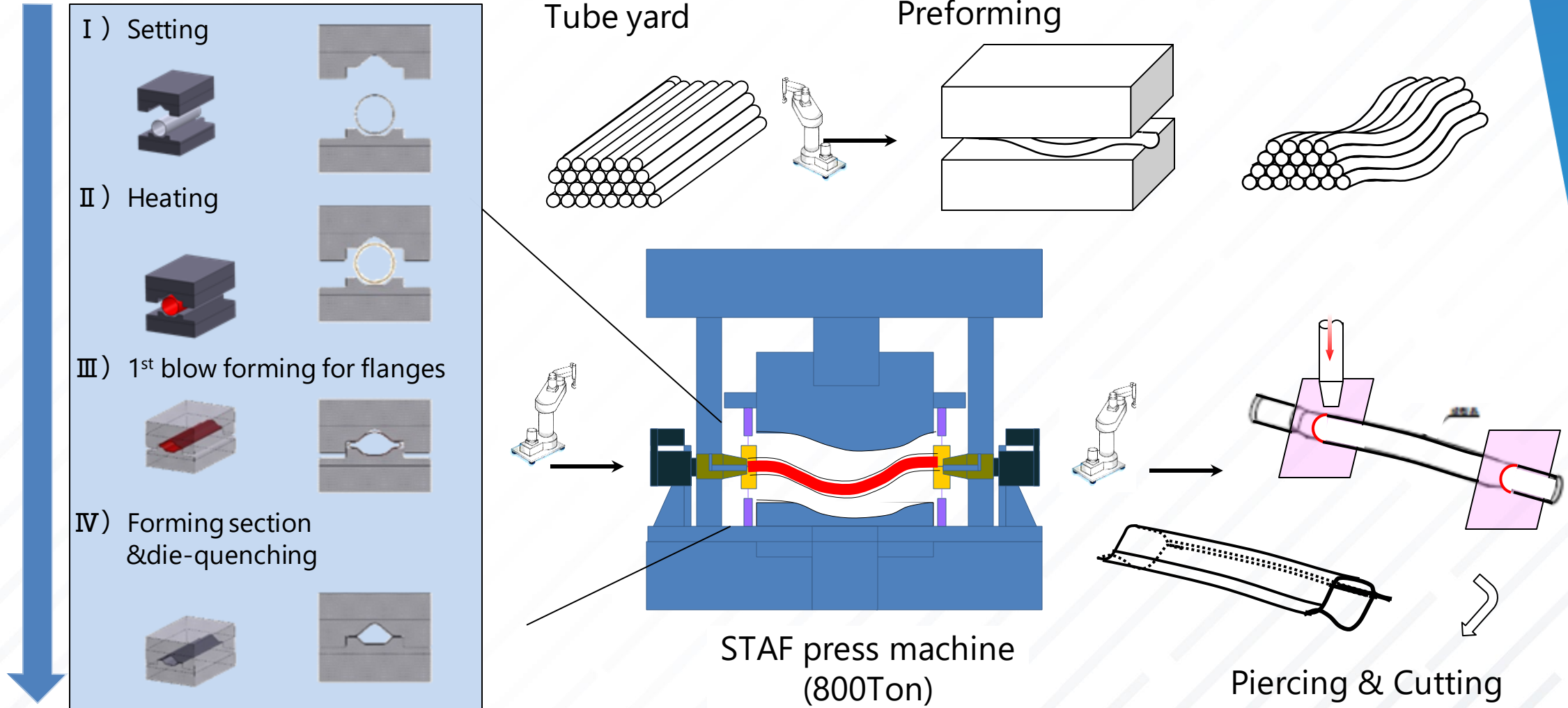

# 1. Introduction of STAF



- 1 . Introduction of STAF
- 2 . Positioning of STAF**
- 3 . STAF's advantages
- 4 . Case study I & II
- 5 . STAF's application

# 2. Positioning of STAF

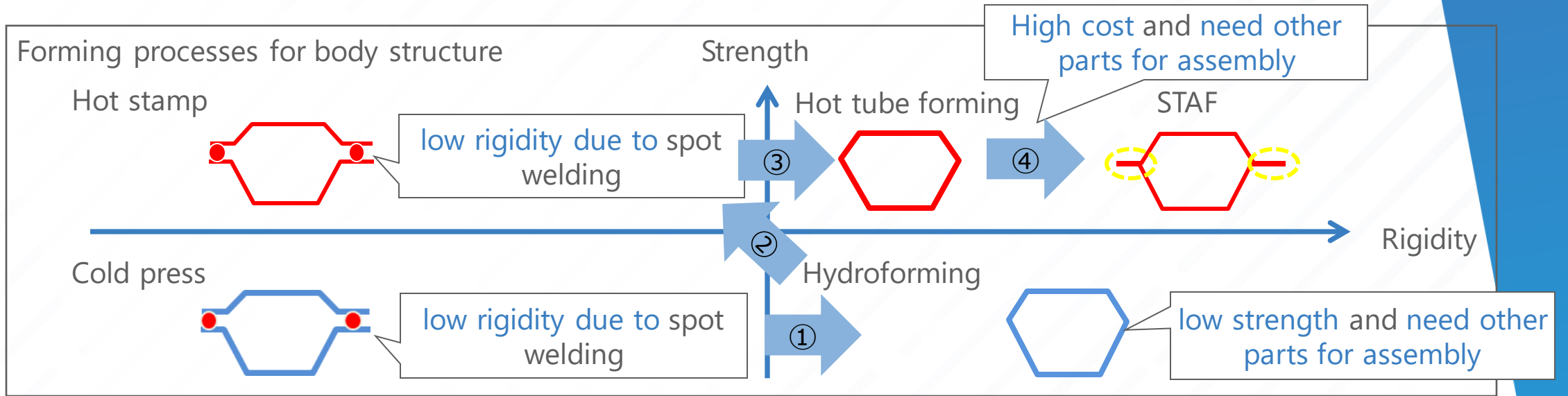

★ Invented    ■ Developed    ■ Promoted    ■ Adopted    ■ To be conventional

Flow of development		1940s	1950s	1960s	1970s	1980s	1990s	2000s	2010s	2020s	2030s
Forming processes	Cold press	Improved material yield, elongation and tension performance									
	Hydroforming		★								
	Hot stamping				★						
	Hot tube forming							★			
	STAF								★		

# 3. Advantages of STAF

- ① Drastic weight reduction
- ② Adjustability  
Performance can be controlled with flexible flanged STAF design
- ③ Cost reduction  
STAF process can integrate surrounding components into STAF  
Equipment for STAF is compact and ecofriendly

① Drastic weight reduction

② Adjustability

③ Cost reduction

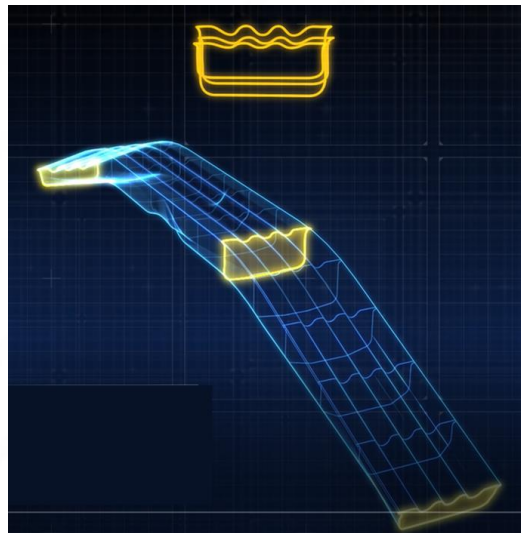
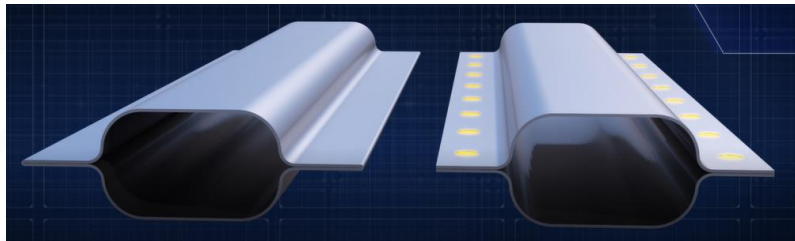

# 3. Advantages of STAF

① Drastic weight reduction; Improved basic performance

■ Drop weight test

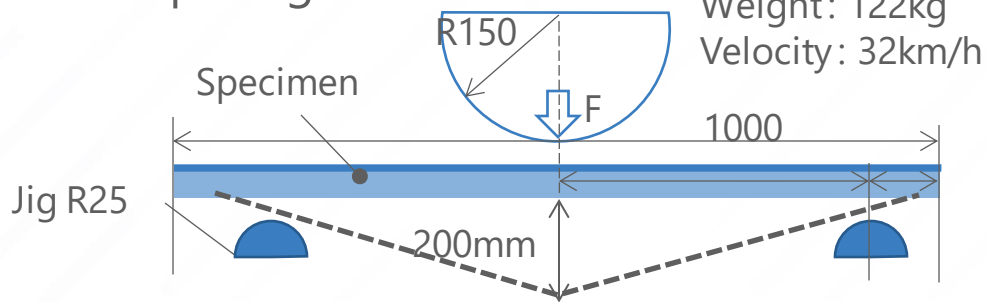

■ Specimen's Cross section



■ After collision

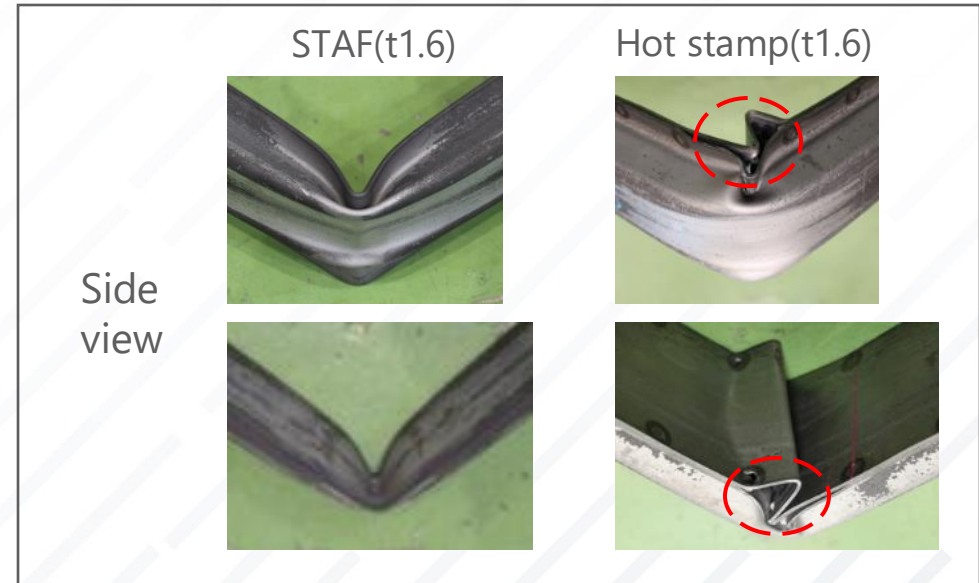

■ Test result

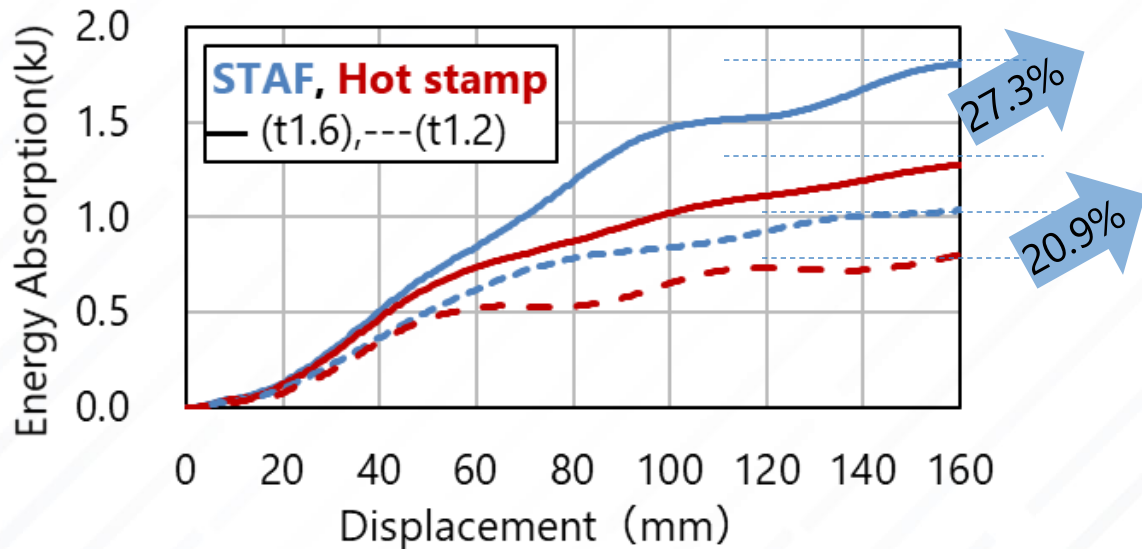

# 3. Advantages of STAF

① Drastic weight reduction; Improved basic performance

■ Drop weight test-2

■ Test movie

■ Specimen's Cross section

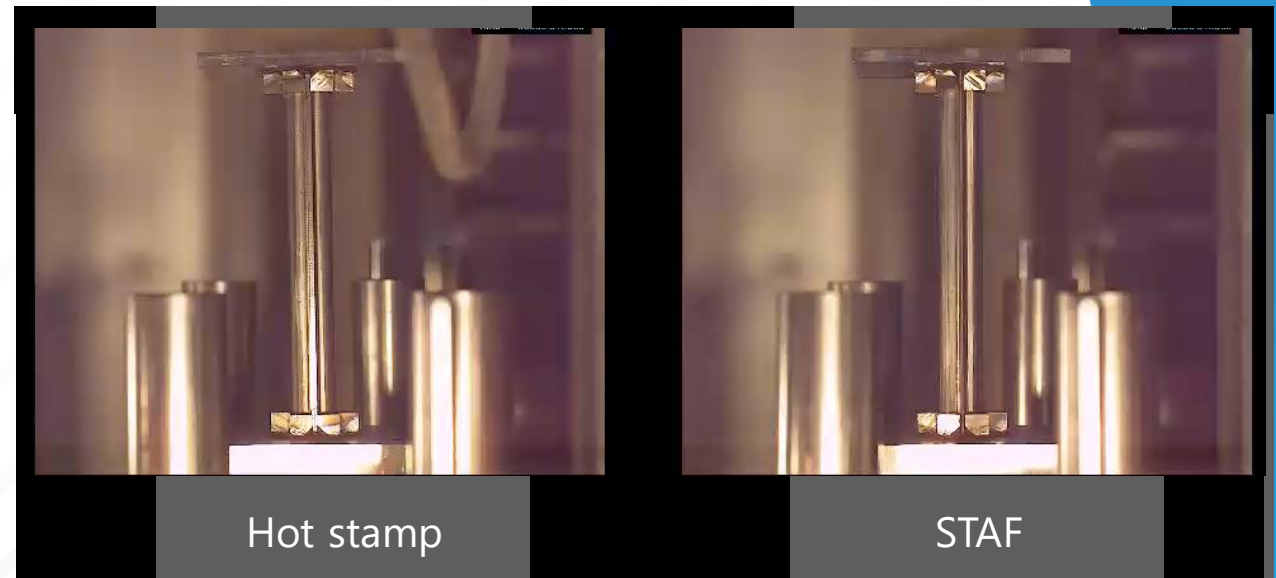
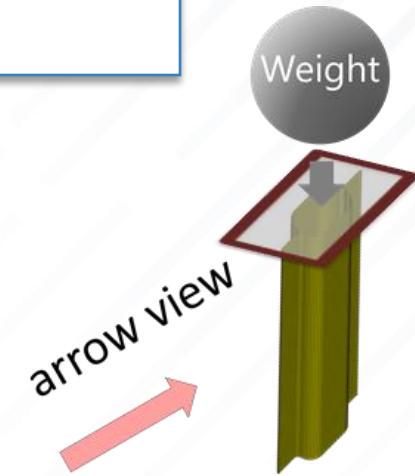
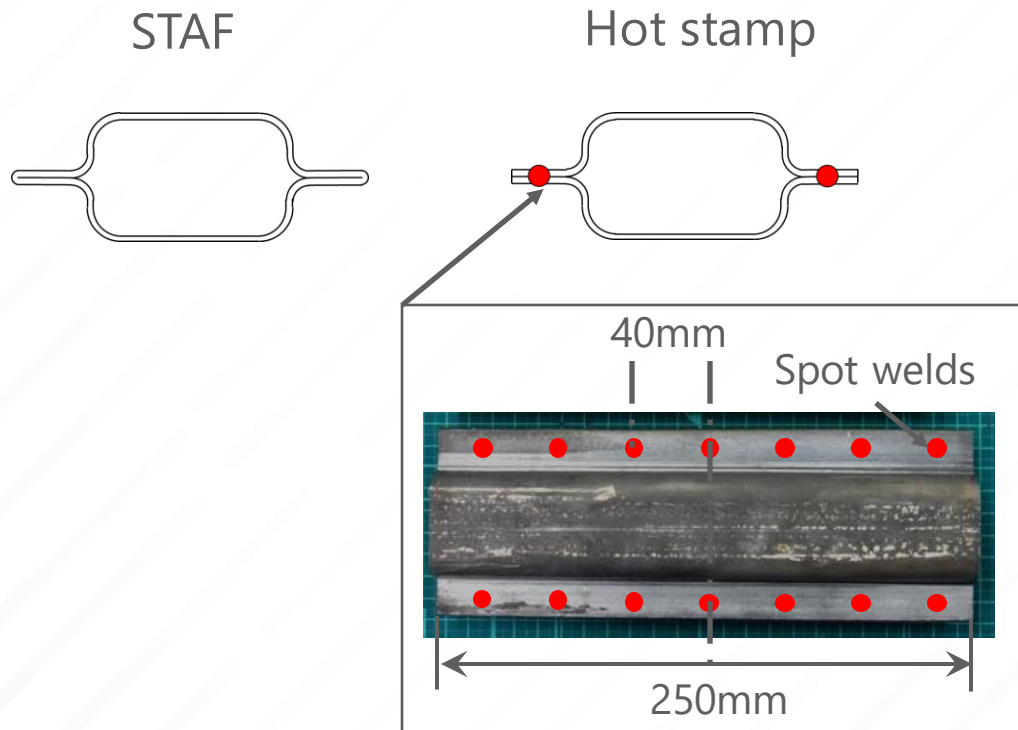

# 3. Advantages of STAF

- ① Drastic weight reduction; Improved basic performance

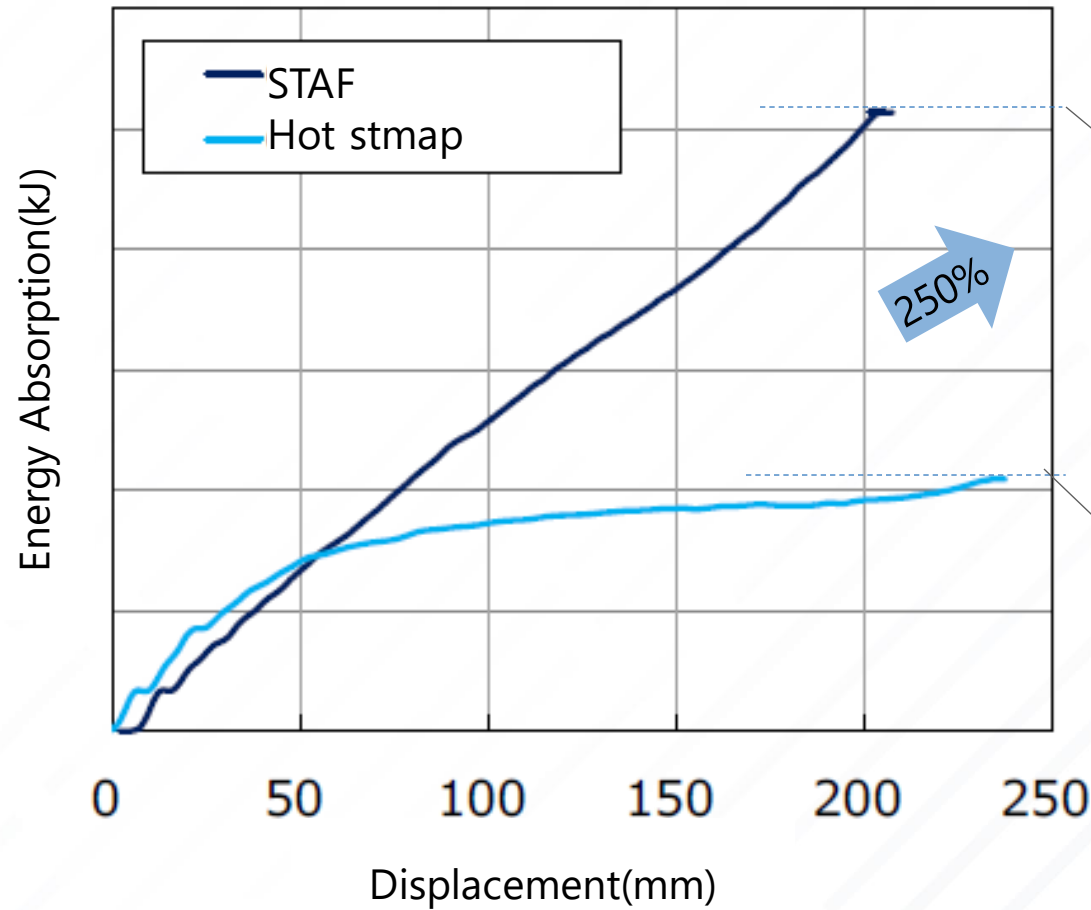

# 3. Advantages of STAF

② Adjustability Performance control with sectional variations and flanges

Models	No Flanged model		Minimum Flanged model	
Criteria Cross-section				
Stroke 20mm				
Stroke 40mm				
Stroke 60mm				

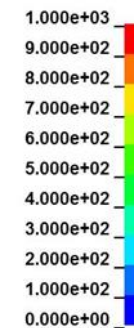

# 3. Advantages of STAF

② Adjustability Adaptation to design layout and performance adjustments

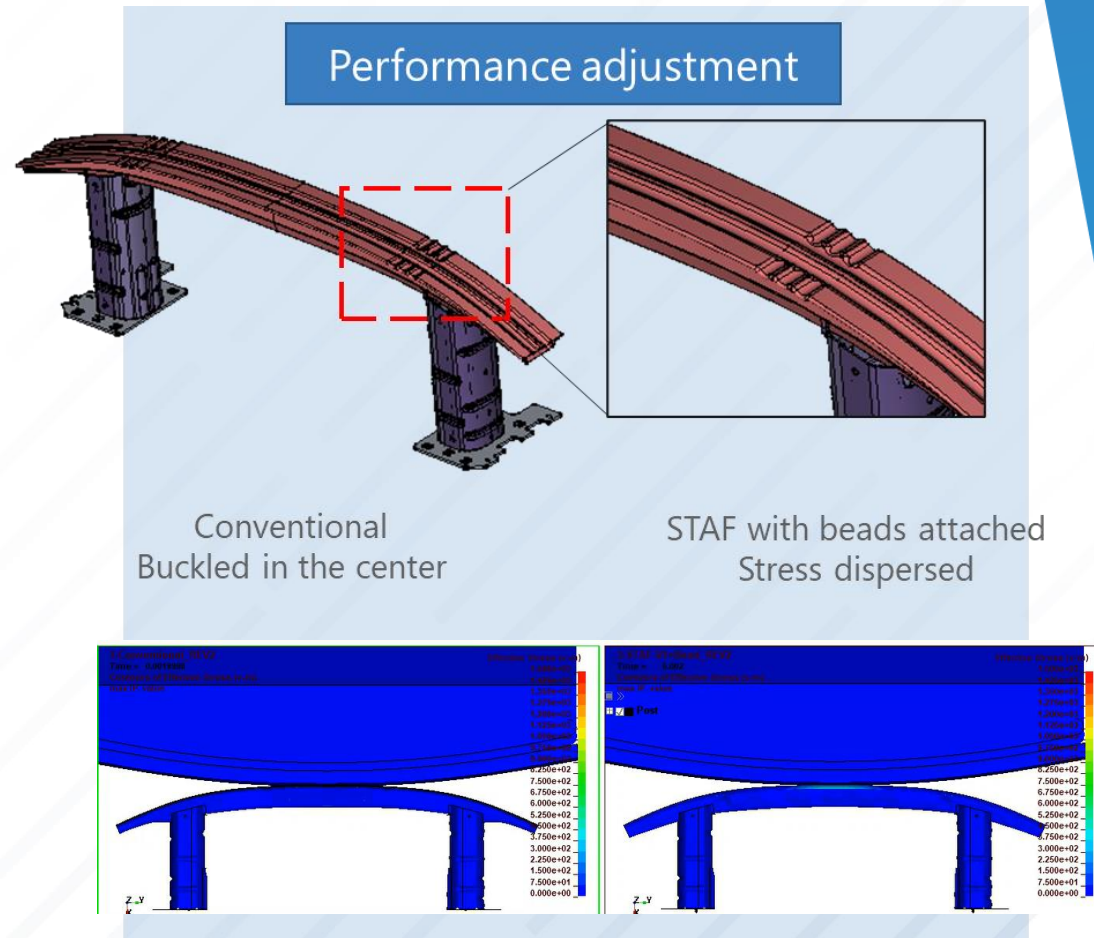
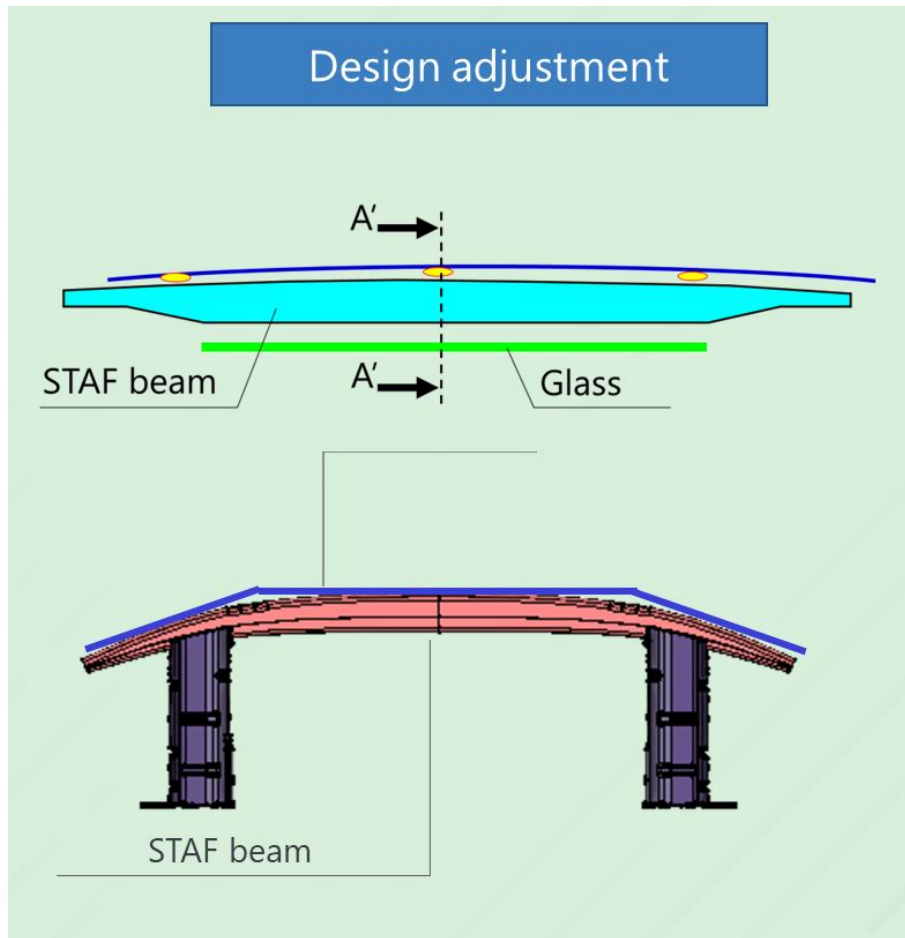

# 3. Advantages of STAF

- Simplification (Integration and optimized equipment)

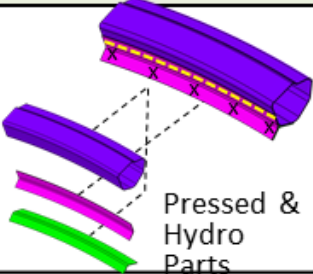
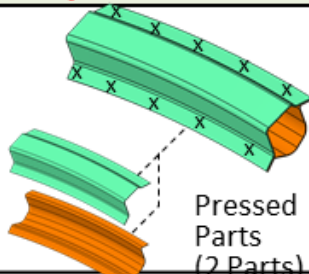
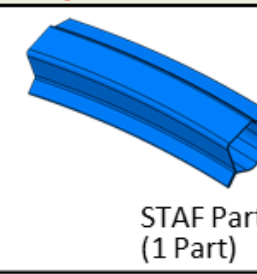
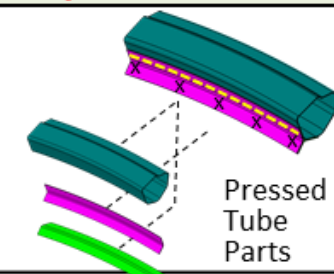
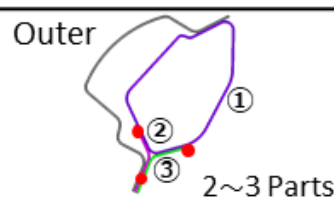
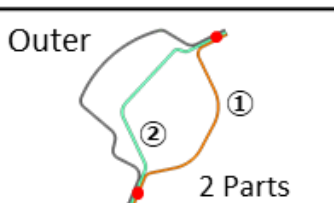
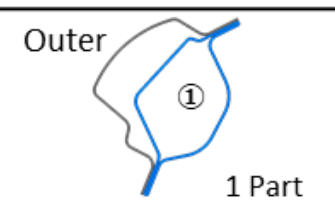
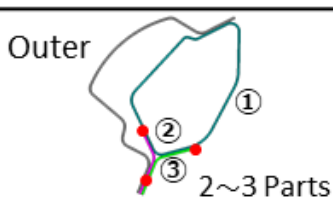
	Hydroforming	Hot stamping	STAF	Hot gas forming
Strength	~980MPa	<b>1,500MPa~</b>	<b>1,500MPa~</b>	<b>1,500MPa~</b>
Parts construction	 <p>Pressed &amp; Hydro Parts</p>	 <p>Pressed Parts (2 Parts)</p>	 <p>STAF Part (1 Part)</p>	 <p>Pressed &amp; Tube Parts</p>
	2~3 Parts	2 Parts	1 Part	2~3 Parts
Cross section image	 <p>Outer 2~3 Parts</p>	 <p>Outer 2 Parts</p>	 <p>Outer 1 Part</p>	 <p>Outer 2~3 Parts</p>
Process	<p>5 processes</p> <ul style="list-style-type: none"> <li>➢ Preforming</li> <li>➢ Hydroforming (3000Ton~)</li> <li>➢ Laser cutting</li> <li>➢ Press forming</li> <li>➢ Welding(ass'y)</li> </ul>	<p>5 processes</p> <ul style="list-style-type: none"> <li>➢ Blanking</li> <li>➢ Heating furnace</li> <li>➢ Hot stamping (2 Sheets &amp; 2 Dies)</li> <li>➢ Laser cutting</li> <li>➢ Welding(ass'y)</li> </ul>	<p><b>3 processes</b></p> <ul style="list-style-type: none"> <li>➢ Preforming</li> <li>➢ STAF form (800Ton~)</li> <li>➢ Laser cutting</li> </ul>	<p>6 process</p> <ul style="list-style-type: none"> <li>➢ Preforming</li> <li>➢ Heating furnace</li> <li>➢ Gas forming</li> <li>➢ Laser cutting</li> <li>➢ Press forming</li> <li>➢ Welding(ass'y)</li> </ul>

- 1 . Introduction of STAF
- 2 . Positioning of STAF
- 3 . STAF's advantages
- 4 . Case study I & II**
- 5 . STAF's application

# **CASE STUDY. I FOR BUMPER REINF. VERIFICATION OF STAF'S BENEFITS**

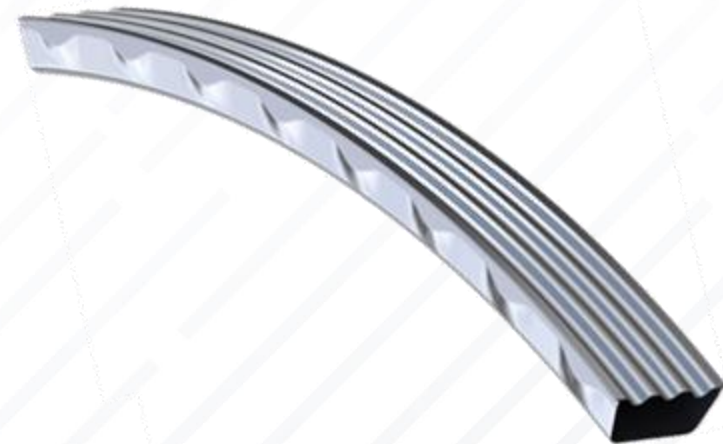

# 4. Case study I

■ Baseline bumper

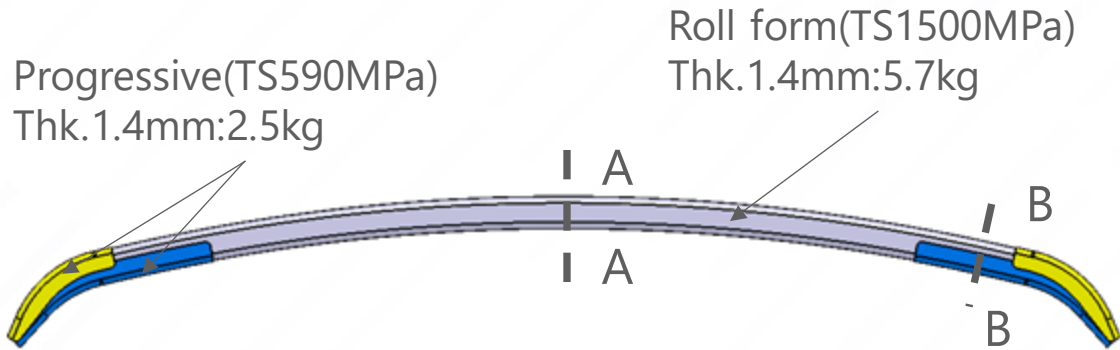

■ STAF

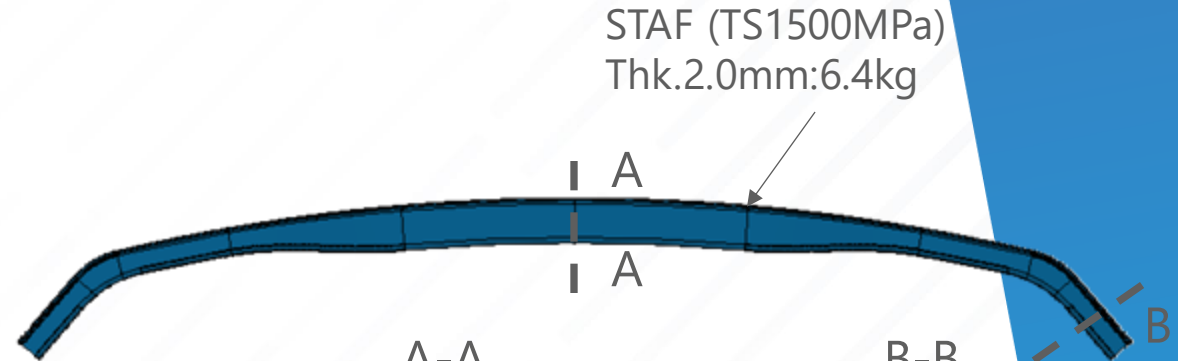

■ Design layout of section from baseline

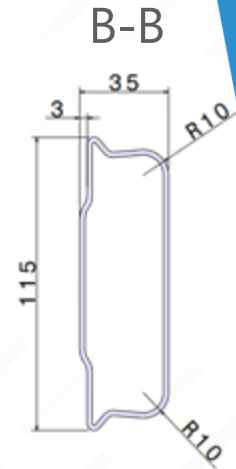
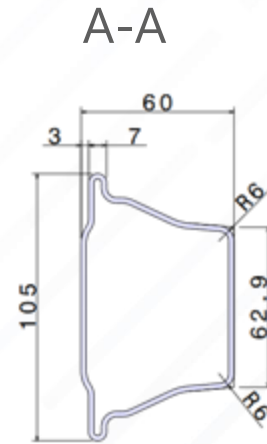
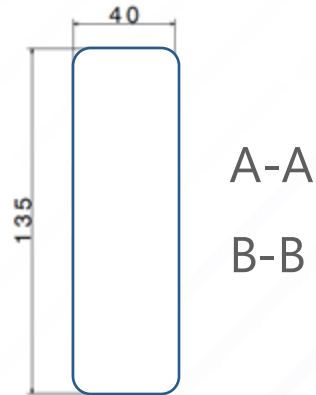

\* The section has been simplified for presentation purposes.

Model	Market	STAF
Pipe Dia.	—	Φ90.0mm
Thk.	1.4mm	2.0mm
Weight	ASSY:8.2kg/Beam:5.7kg	<b>6.4kg(-22%)</b>

# 4. Case study - I

■ Evaluation: We have studied various requirements as below. We have confirmed equivalent performance of STAF. In order to prove the basic performance of STAF, I will explain the performance of 3-point bending.

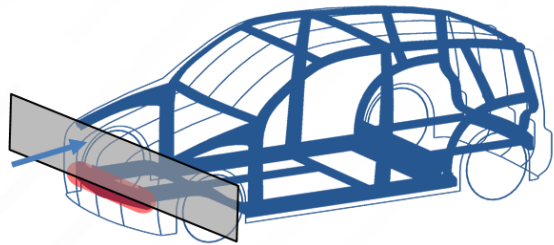

Frontal Crush(50%Overlap)

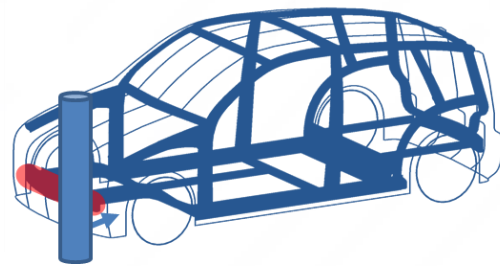

SOL

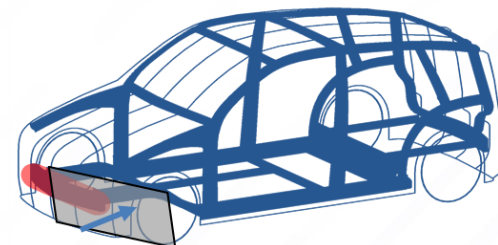

Oblique Crush

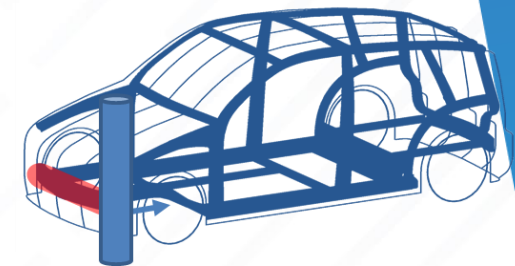

Cantilever

## ■ 3-point bending test(CAE)

Solver : LS-DYNA

Stroke velocity:1.0mm/sec

Stroke amount:150mm

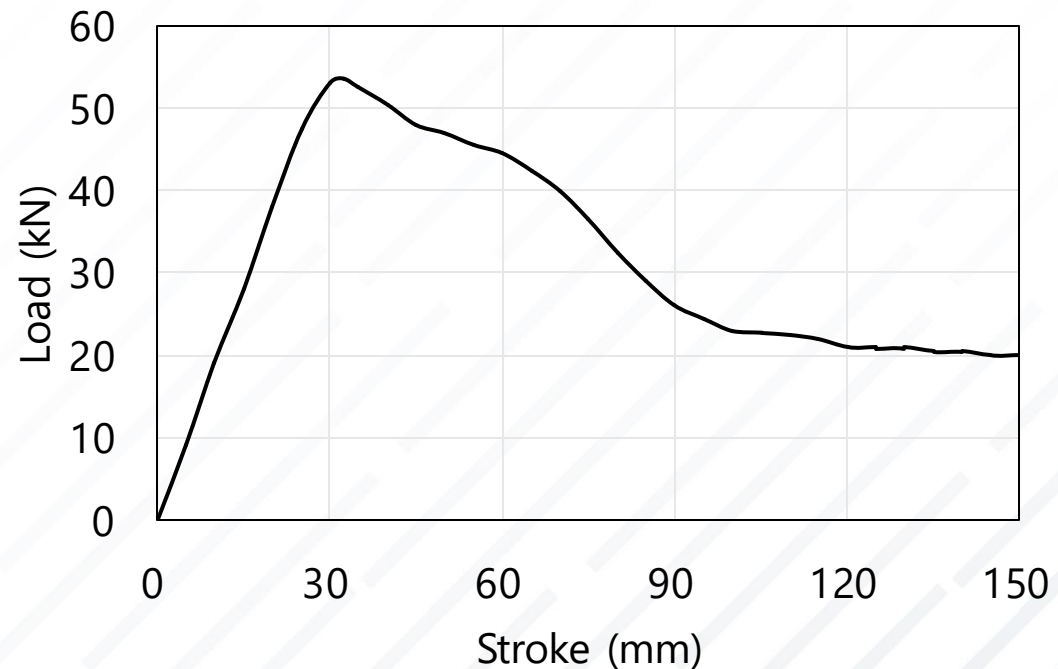
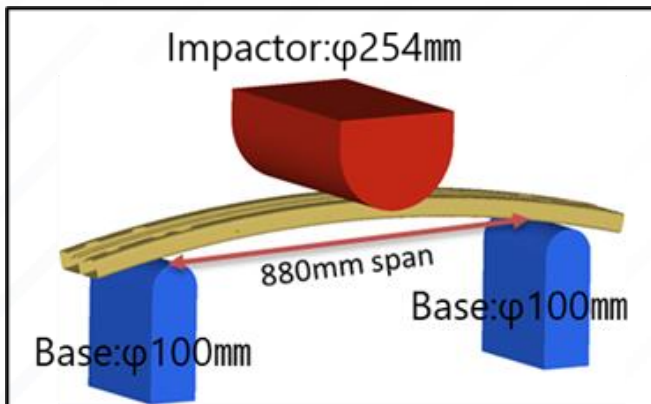

# 4. Case study I

■ Test result (3-point bending)

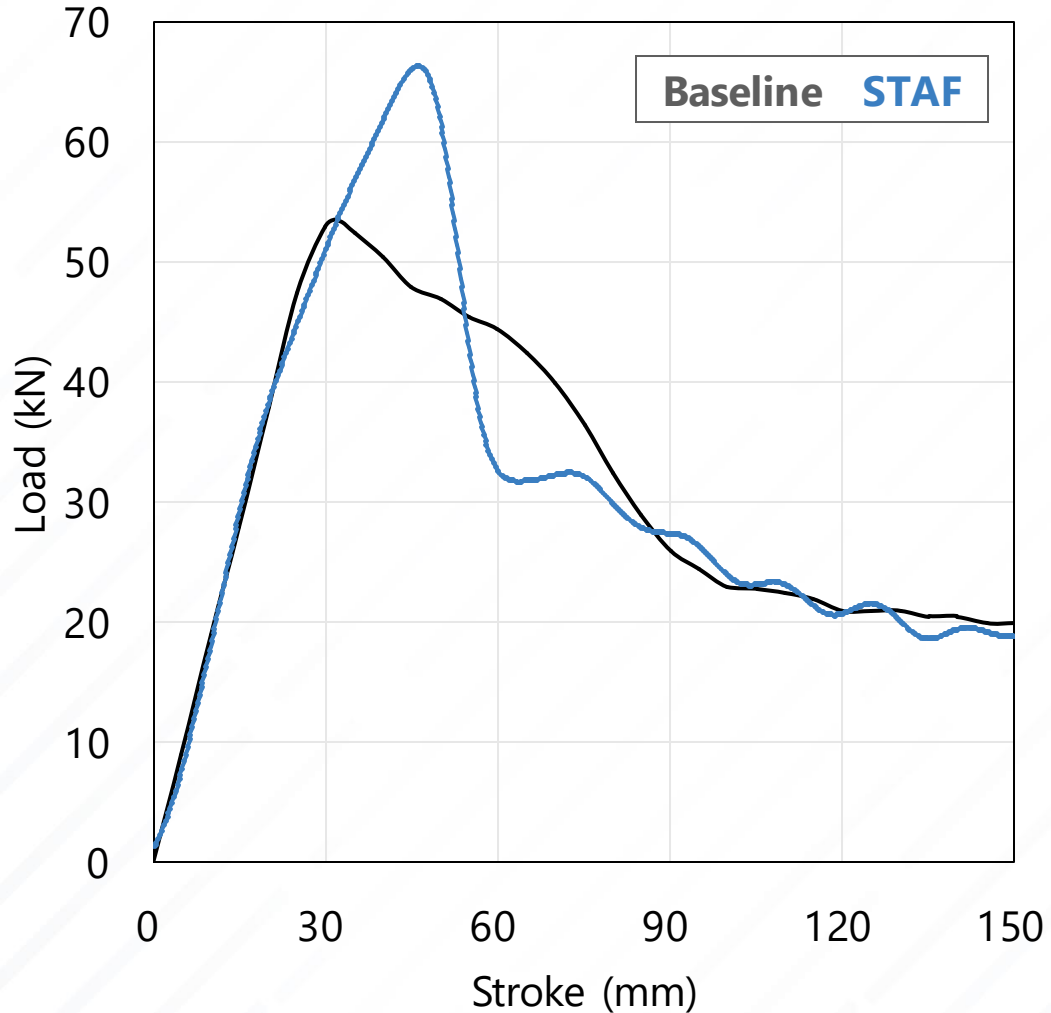

## Deformation mode

Initial stroke	Mid stroke	Final stroke
Top surface is deformed. With the effect of reinforce beads and flanges, reaction force is increased.	The base of the flanges hits the belly wall and receives the load at the cross-sectional body.	The belly wall beads suppress the deformation of section and increase energy absorption.

Model	Market	STAF
Pipe Dia.	—	Φ90.0mm
Material Property	TS1500MPa	TS1500MPa
Thk.	1.4mm	2.0mm
Num. of parts	5 parts	<b>1 part</b>
Weight	ASSY:8.2kg/Beam:5.7kg	<b>6.4kg(-22%)</b>

## 4. Case study I

### ■ Summary

#### STAF applicability to Bumper beam

1. In various test conditions, it is possible to reduce **the weight by 22%**, compared with the baseline bumper. (Apple to Apple comparison within same design constraints)
2. By **reducing the number of parts, tools and welding assembly processes**, manufacturing cost will be reduced.
3. Realize localized shape changes and tight bending configurations, creating flanged shapes that are **not achievable with other manufacturing processes**.

# **CASE STUDY. II** FOR DOOR BEAM VERIFICATION OF STAF'S BENEFITS

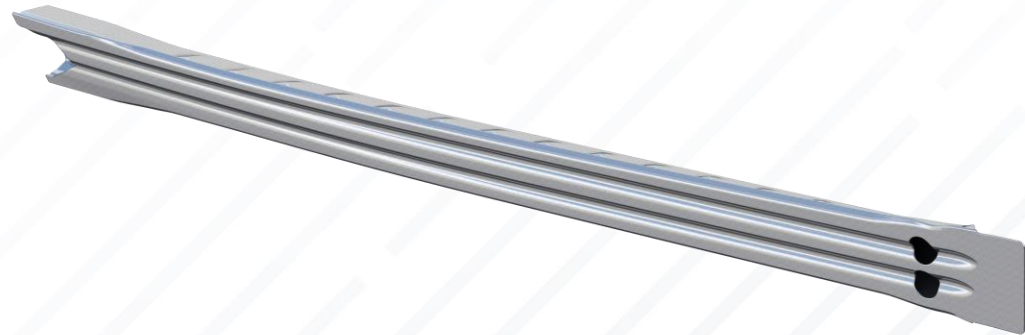

# 4. Case study II

■ Baseline door beam: Select a door beam installed on front doors of commercially available vehicles that have obtained a GOOD rating in the IIHS SIDE IMPACT TEST. We developed this as a benchmark target.

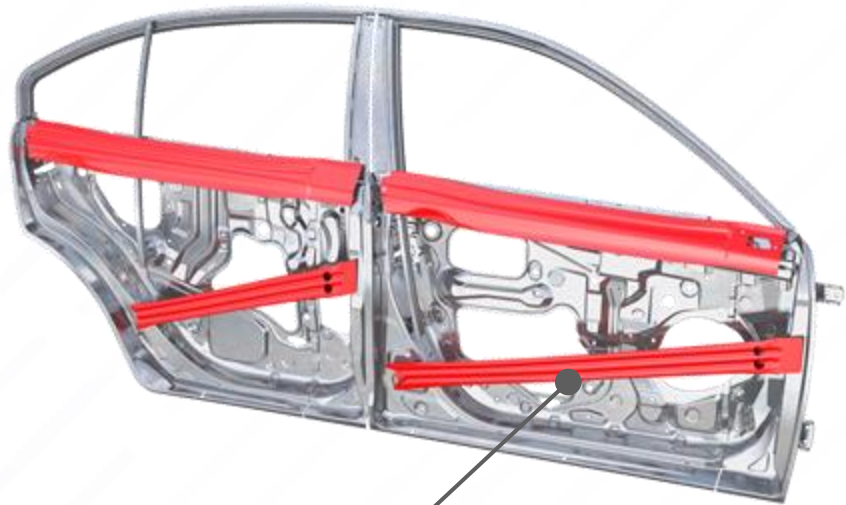

Material / Weight of Market Door Beam

Part	Material	Weight
Pipe Beam (Fai35.0mm / t3.2)	Steel (*TS=1800MPa)	2.6kg
Side Bracket Fr	Steel	0.7kg
Side Bracket Rr	Steel	
Bracket a	Steel	
Bracket b	Steel	
Bracket c	Steel	
①Target Weight :2.8kg (-15%)		

# 4. Case study II

■ Evaluation: 3-point bending test

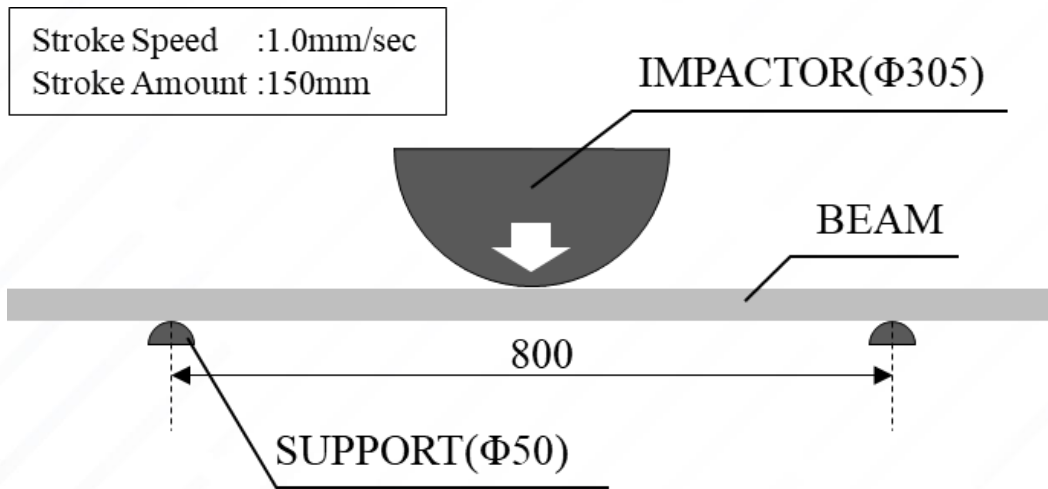

Test Conditions for Static 3-point Bending Test

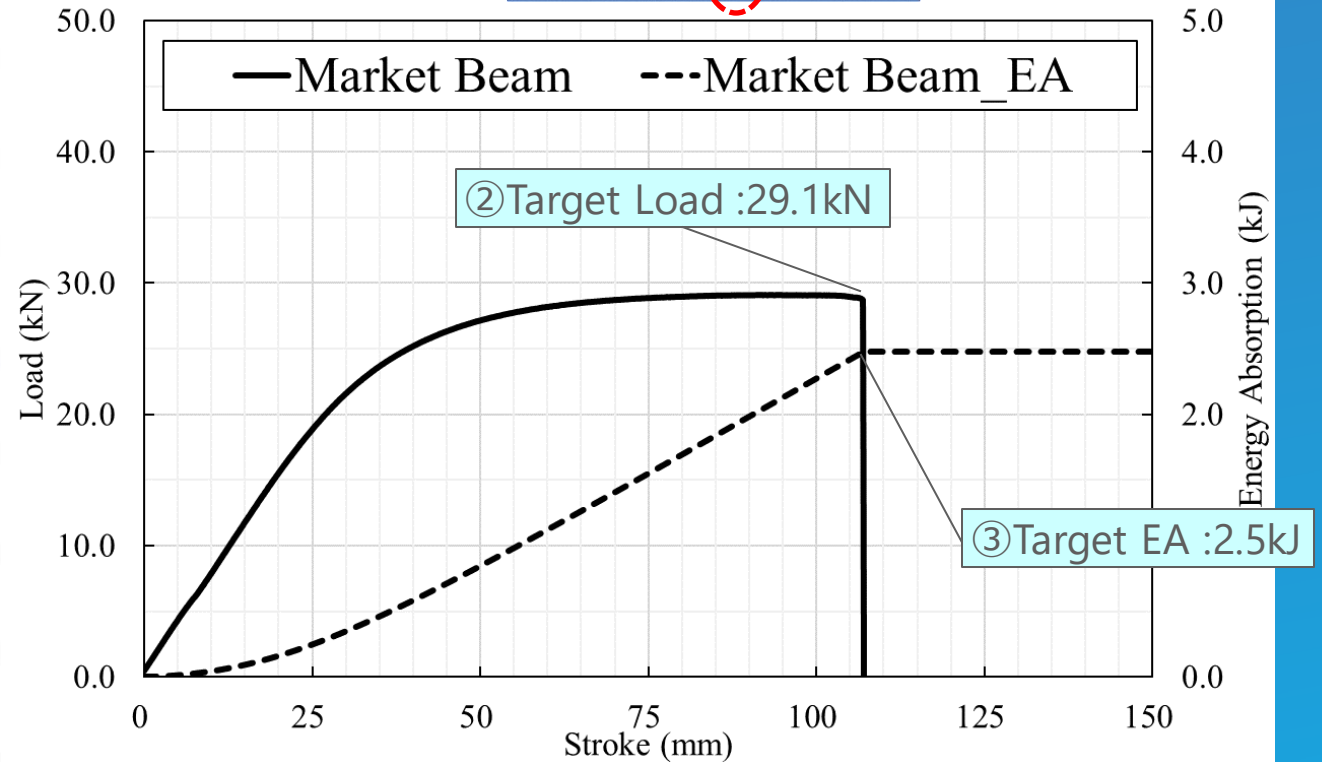
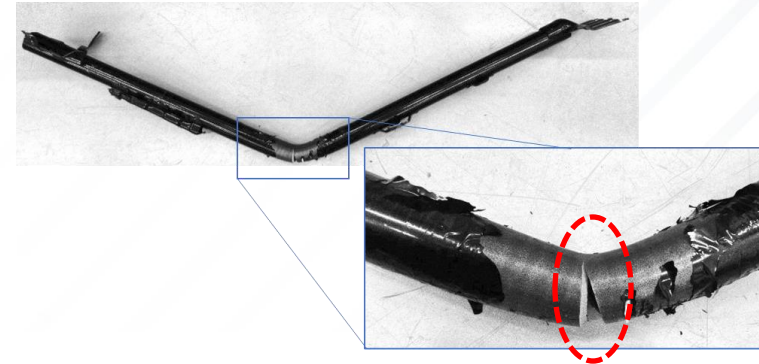

Test Result for Market Door Beam

# 4. Case study II

- Characteristic features of the STAF design shape-1
- ❖ The cross-section flexibly changes its shape at each position

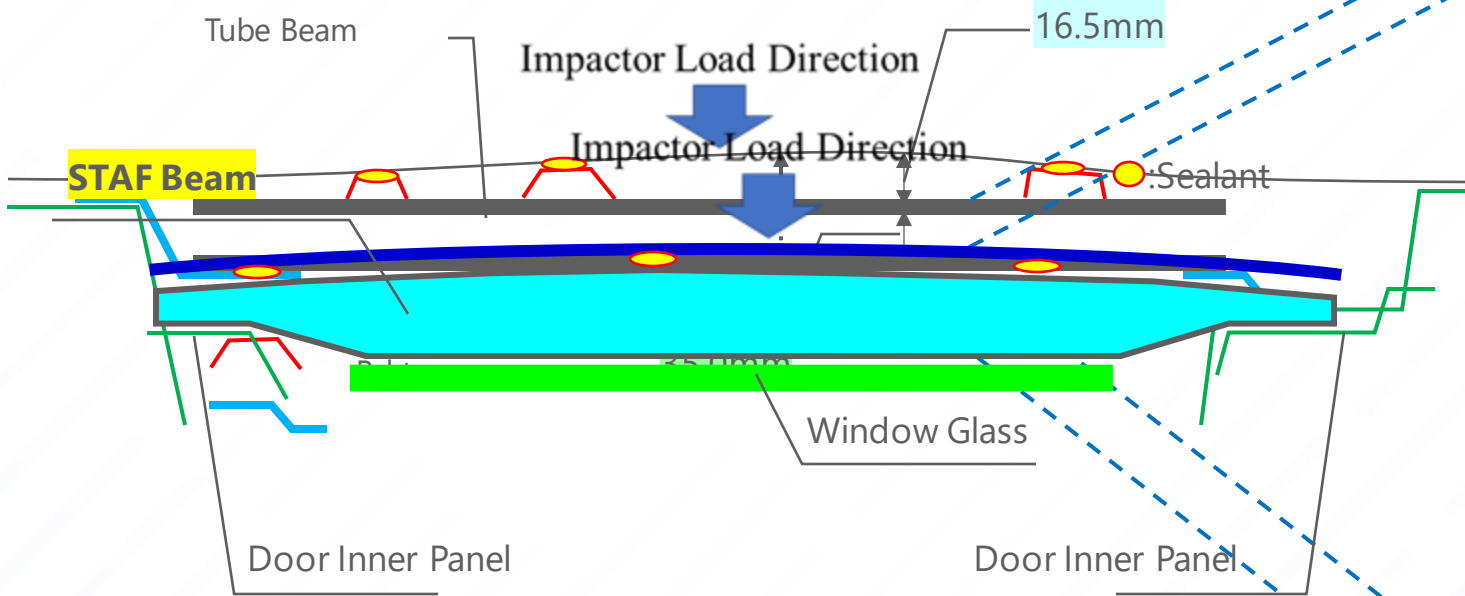

Layout of door beams

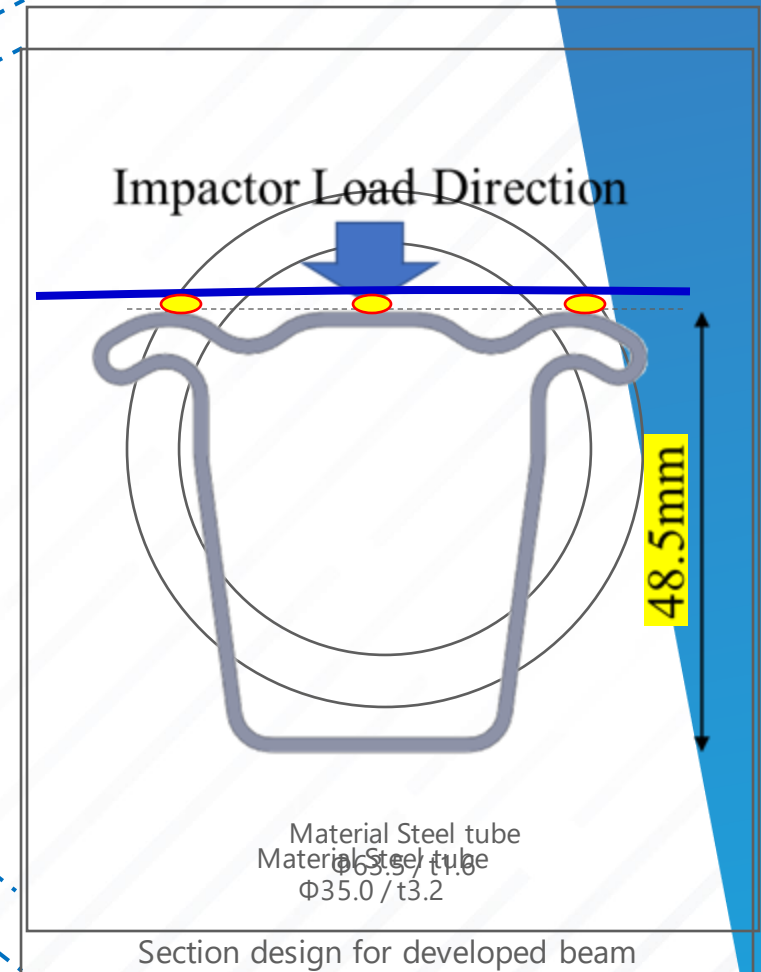

Section design for developed beam

$$\text{Section Height} : \underset{\text{Clearance}}{16.5\text{mm}} + \underset{\text{Beam Height}}{35.0\text{mm}} - \underset{\text{Min Clearance}}{3.0\text{mm}} = \underset{\text{Total Height}}{48.5\text{mm}}$$

# 4. Case study II

- Characteristic features of the STAF design shape-2
- ❖ Trigger Bead Shape to Avoid Buckling

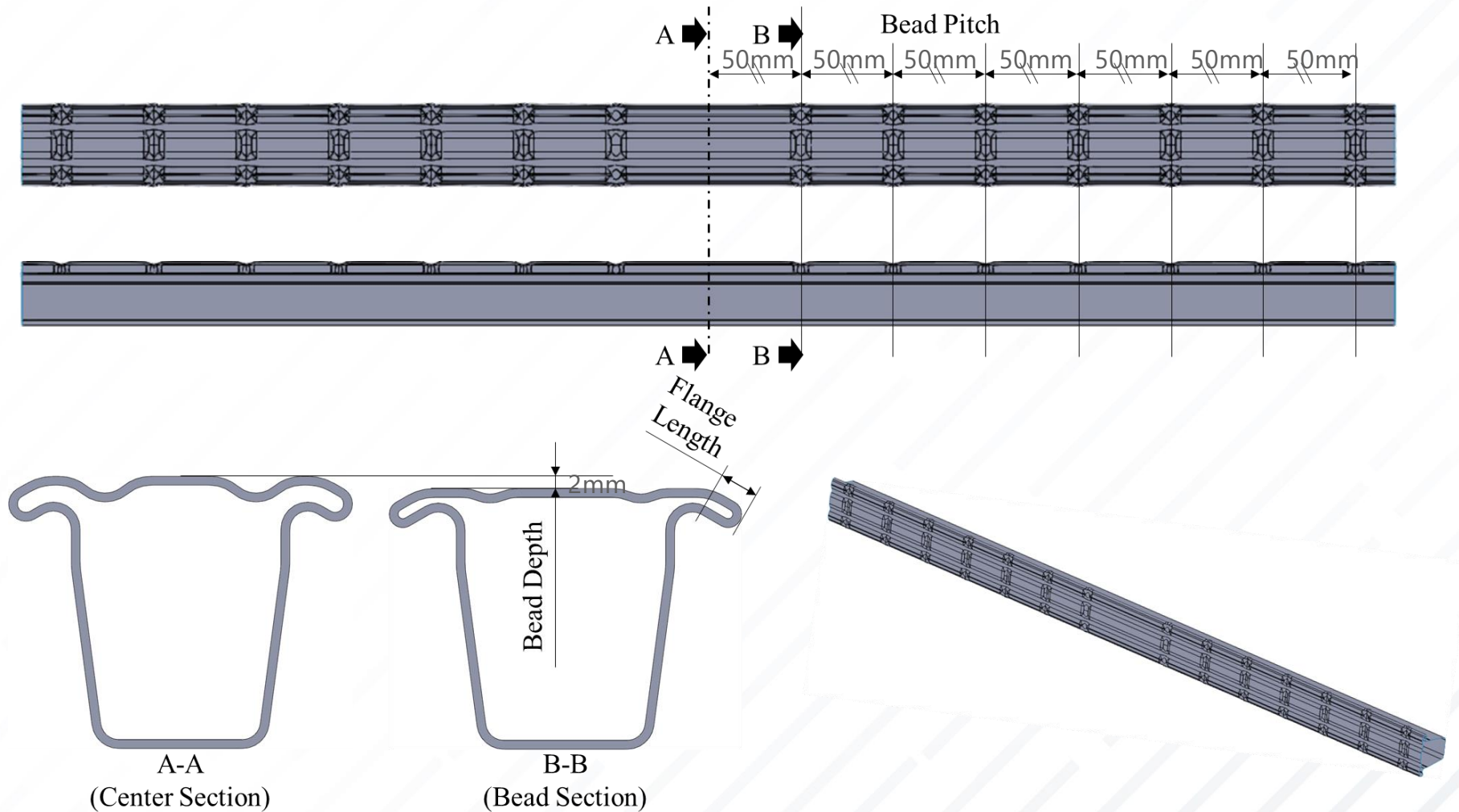

# 4. Case study II

## Evaluation results

STAF with trigger beads

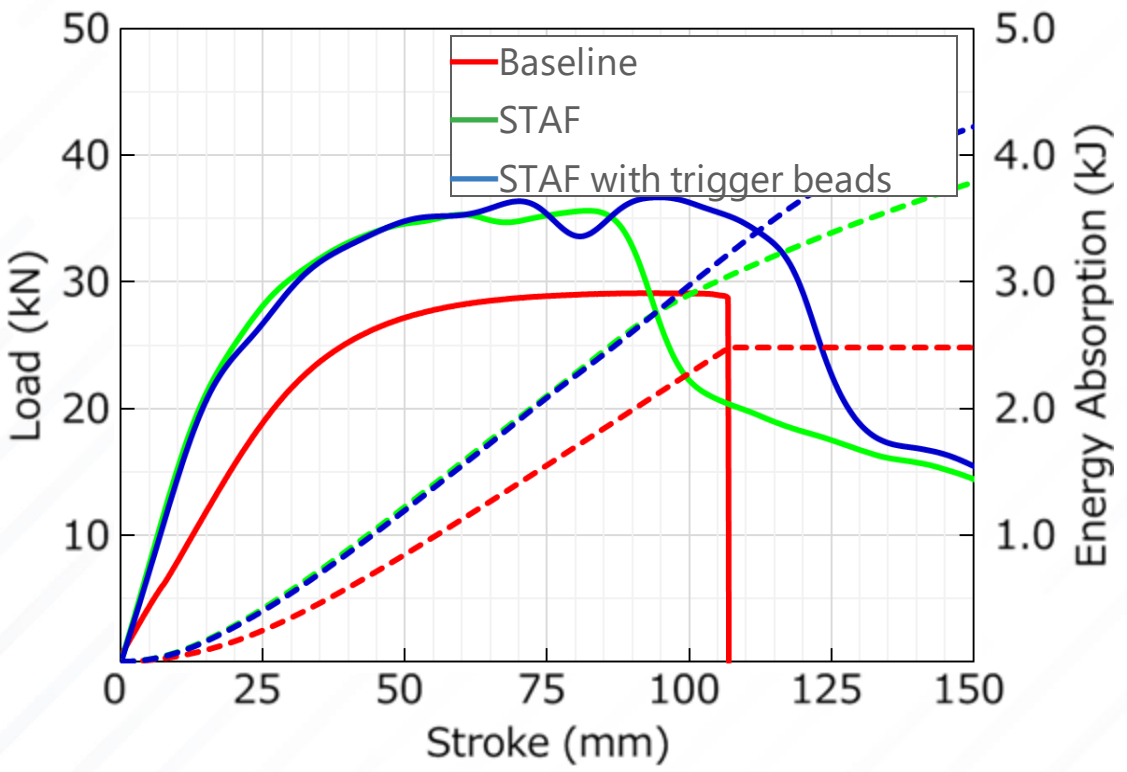
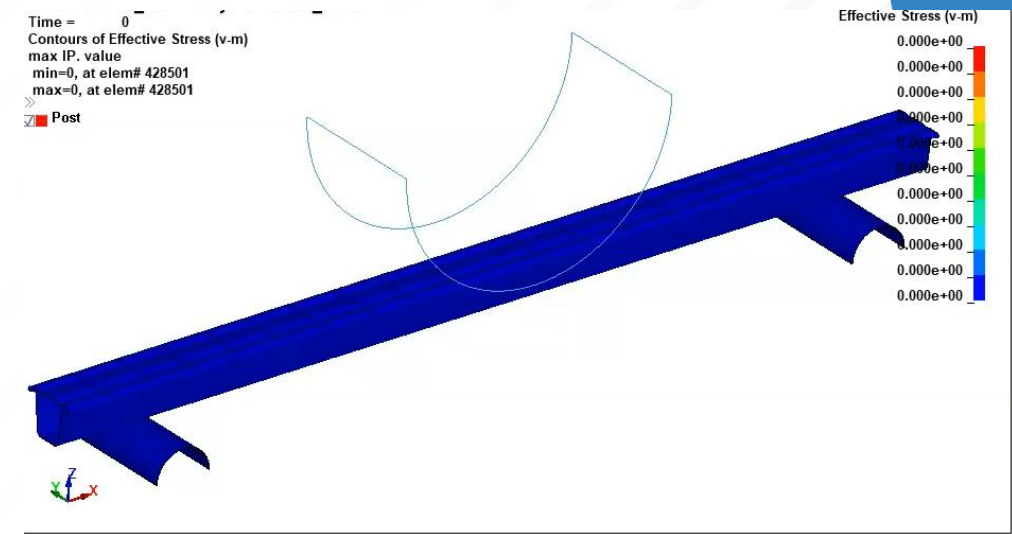

CAE result for STAF beam with bead shape

Model	Baseline	STAF
Pipe Dia.	Φ35.0mm	Φ63.5mm
Material Property	TS1800MPa	TS1500MPa
Thk.	3.2mm	1.6mm
Num. of parts	6 parts	<b>1 part</b>
Weight	3.3kg	<b>2.8kg(-15%)</b>
Fmax(kN)	29.1	<b>36.3(+25%)</b>
EA@110mm(kJ)	2.5	<b>3.3(+30%)</b>

## 4. Case study II

### ■ Summary

#### STAF applicability to A-pillar test

1. The STAF beam has a flanged closed cross-section structure, and the expansion of the cross-section size by **utilizing most of the layout space** can perform high strength and energy absorption.
2. The STAF beam can avoid buckling of the beam by alleviating the stress concentration in the center of the beam with **the characteristic trigger bead shape**.
3. The STAF beam achieves **15% weight reduction, 25% increase in peak load, and 30% improvement in energy absorption** compared to the commercial pipe beam.

# 5. Application for STAF

The parts below are just examples of the prototype parts that we are studying with our customers(OEMs and Tier1 suppliers). We have verified that compared with conventional body frame parts, STAF's unique high-strength tubular flanged components can make joining easier, performance higher, manufacturing cost lower.

**Red:** Body frame parts to which STAF is applicable



# 5. Application for STAF

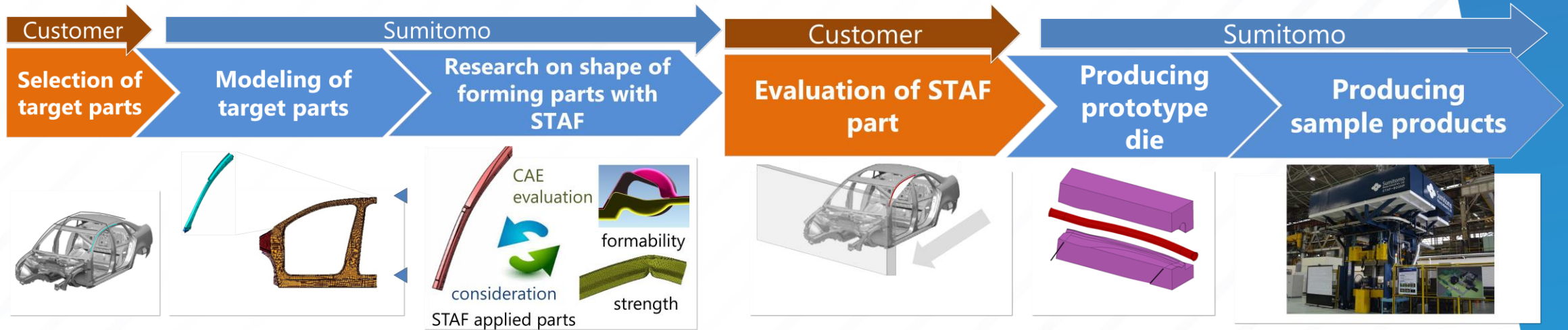

Through these activities, Sumitomo can provide the technical know-how in the feasibility and strength confirmation CAE that have already been verified, and the confirmation results such as the weldability, formability and corrosion protection of STAF product, etc., The adoption of STAF by OEMs and Tier1 suppliers can be strongly promoted.

## 5. Application for STAF

- In 2022, we installed STAF equipment at Topiac Co., Ltd. In this case, the existing press machine was modified and utilized for STAF. From 2023, we began accepting orders for STAF parts. Currently, it is in operation as a subcontractor for prototyping and producing body frame parts.



Confidential Only

STAF manufacturing equipment at TOPIA

STAF manufacturing equipment at SHI

# For more information

Thank you all for listening!

If you are interested in STAF and like to hear more details, please feel free to contact us at:



---

Ryuichi Funada (FD)

Sales Engineering

STAF Project

Advanced Technology of Plasticity - SBU

mail:ryuichi.funada@shi-g.com

cell:(614)896-0282

cell:+81-(0)80-8072-7350

 **Sumitomo Heavy Industries (USA), Inc.**

Office

5100 Parkcenter Ave Dublin, OH 43017

---