

GREAT DESIGNS IN **STEEL**

Steel E-Motive: Steel-Intensive Ride Sharing Vehicle Concepts Deliver Sustainable and Affordable Mobility Solutions

George Coates and Russ Balzer

WorldAutoSteel

Agenda

- Introduction to WorldAutoSteel and Steel E-Motive
- Project Motivation
- Steel E-Motive Body Concepts and Innovations
- Costing Calculations
- Sustainability Assessment
- Question and Answer

STEEL E-MOTIVE

IN PARTNERSHIP WITH



www.steelemotive.world



WorldAutoSteel's Motivation for Steel E-Motive



Global Net-Zero Emissions ambitions.



Urbanization and waning interest in vehicle ownership point to new transport opportunities in megacities.



Extensive research over a five-year period revealed global investment and growth in autonomous MaaS fleet ownership.



Demonstration that steel can be a significant enabler for reaching Net Zero Emissions with safe, sustainable, and affordable mobility solutions.

Steel E-Motive: Advanced High-Strength Steel Body Structures For New, Fully Autonomous "Mobility as a Service" Electric Vehicles

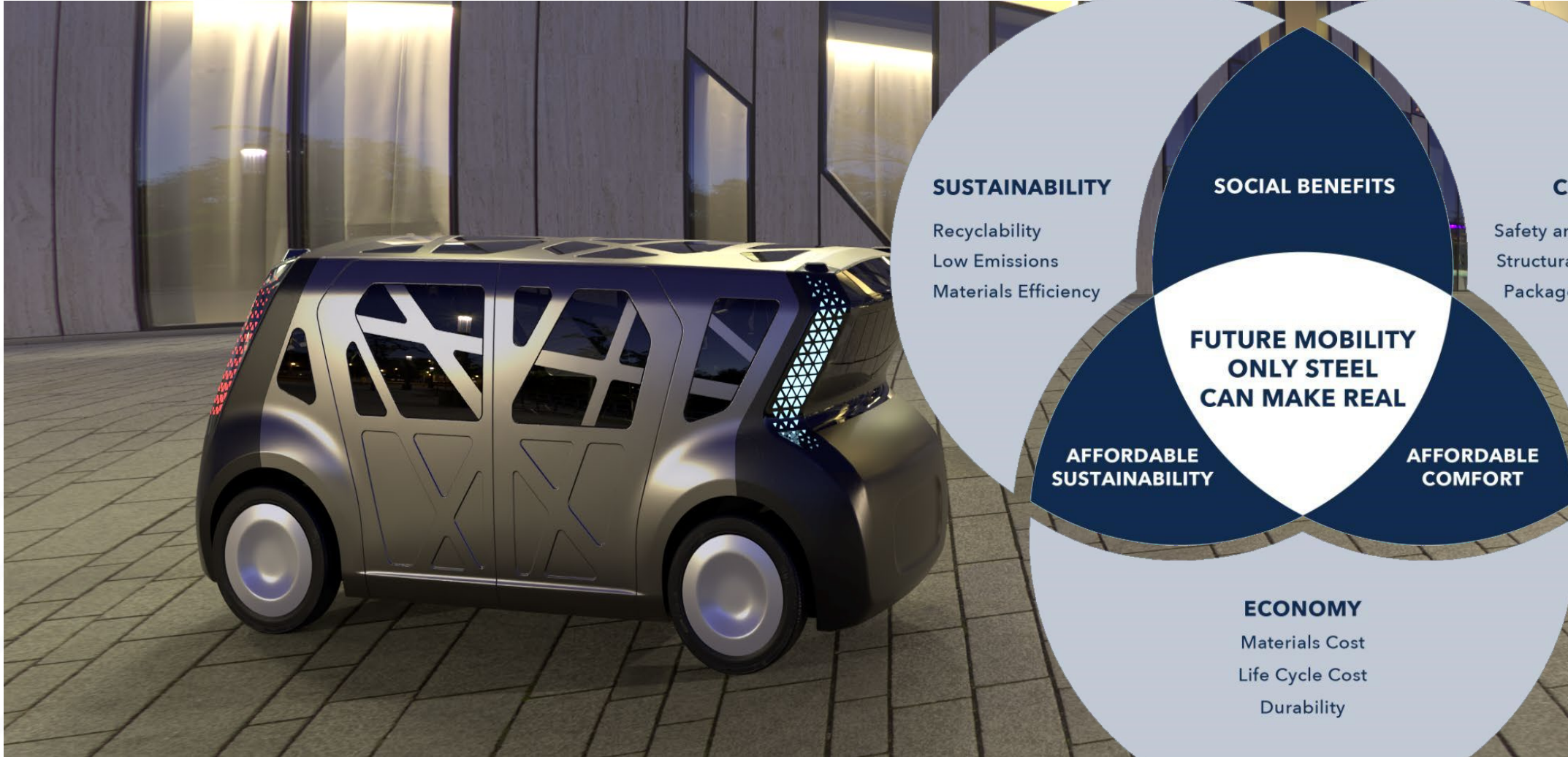

SUSTAINABILITY

Recyclability
Low Emissions
Materials Efficiency

SOCIAL BENEFITS

**FUTURE MOBILITY
ONLY STEEL
CAN MAKE REAL**

COMFORT

Safety and Strength
Structural Solutions
Package Efficiency

**AFFORDABLE
SUSTAINABILITY**

**AFFORDABLE
COMFORT**

ECONOMY

Materials Cost
Life Cycle Cost
Durability

Two Steel E-Motive Vehicle Concepts: One Shared Platform, Intended for Urban and Extra-urban Mobility Services

SEM1

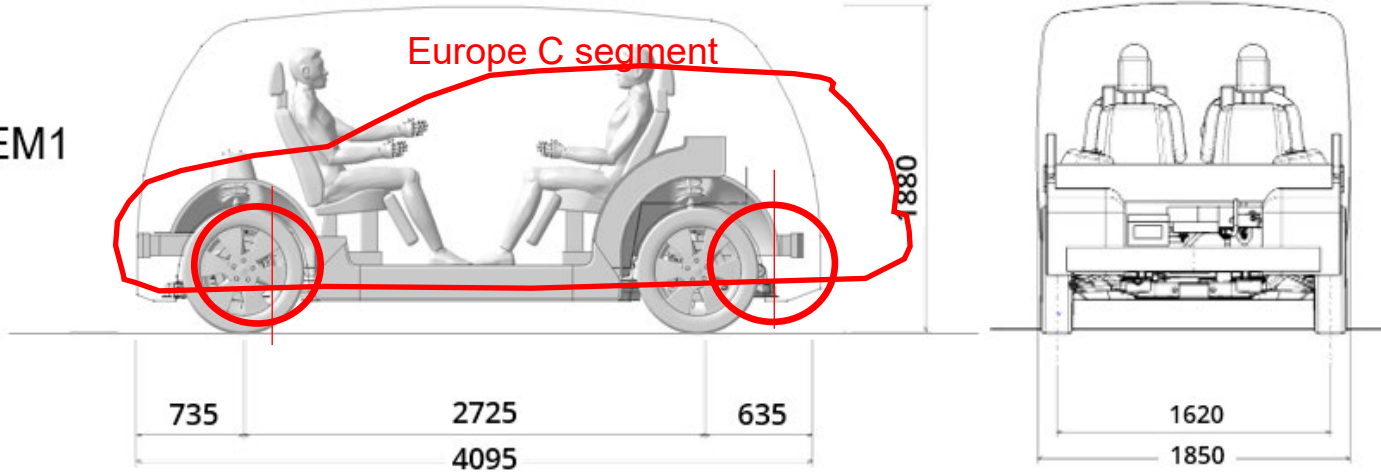

- 4 passengers, urban (city) mobility operations
- 75kWh battery
- Front electric motor
- 500 km range on single charge
- Vmax = 120 kph
- Level 5 autonomy
- 1512 kg kerb weight

SEM2

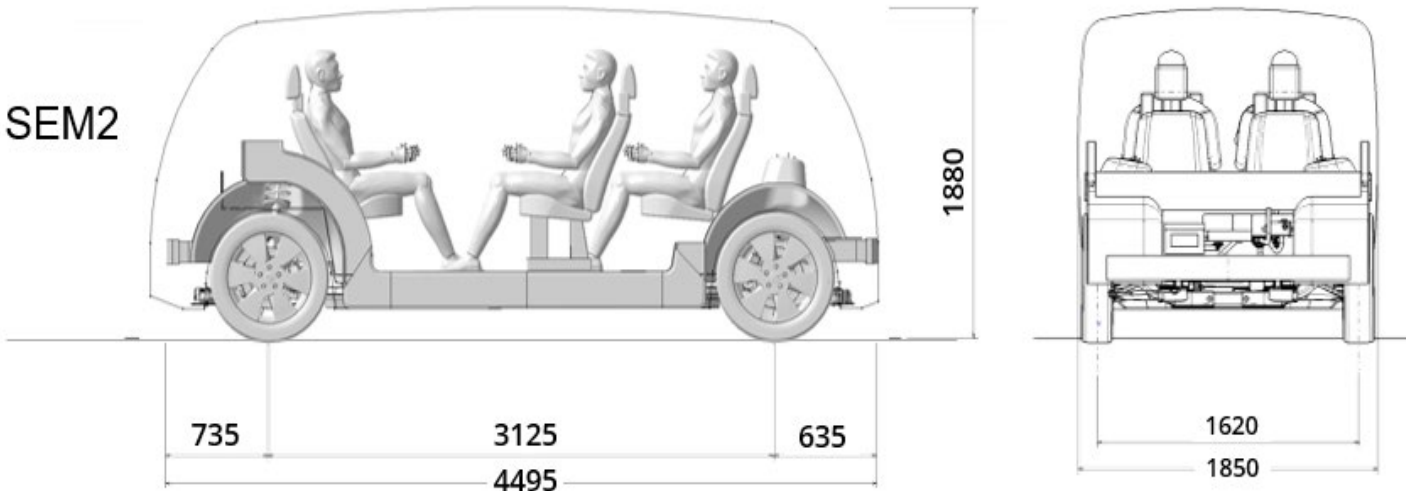

- 6 passengers, intra-city mobility
- 96kWh battery
- Front and rear electric motor, 4-wheel steer
- Maximum commonality SEM1-SEM2. 400mm wheelbase stretch
- Vmax = 120 kph
- Level 5 autonomy
- 1873 kg kerb weight

Steel E-Motive SEM1 Body in White: Advanced High-Strength Steel Grade Utilization



- Purpose-designed BIW for fully autonomous vehicle. B pillar is in the side closures
- Stamped, fabricated, high-volume solution. 204 parts
- AHSS portfolio allows the right steel grade and gauge in the right place
- 66% Gigapascal steels (> 1000 MPa tensile strength); allow lightweighting without sacrificing performance
- (“Alternative grades” specification also developed, demonstrating breadth of AHSS application)

BIW weight = 282kg

Avg. Tensile Strength = 1259 MPa

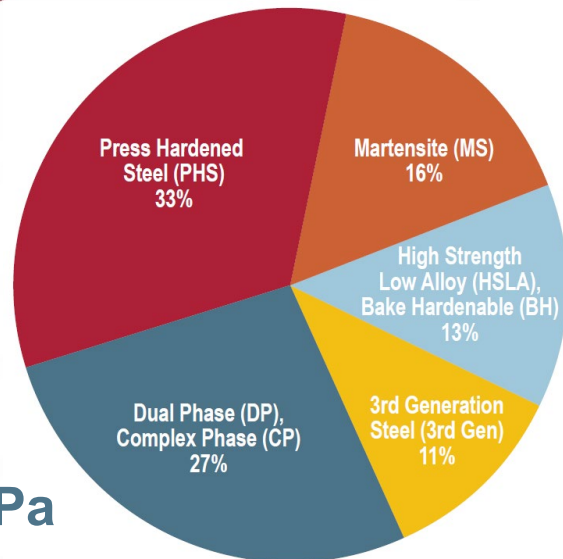

Steel E-Motive: Seven Key Steel Innovations

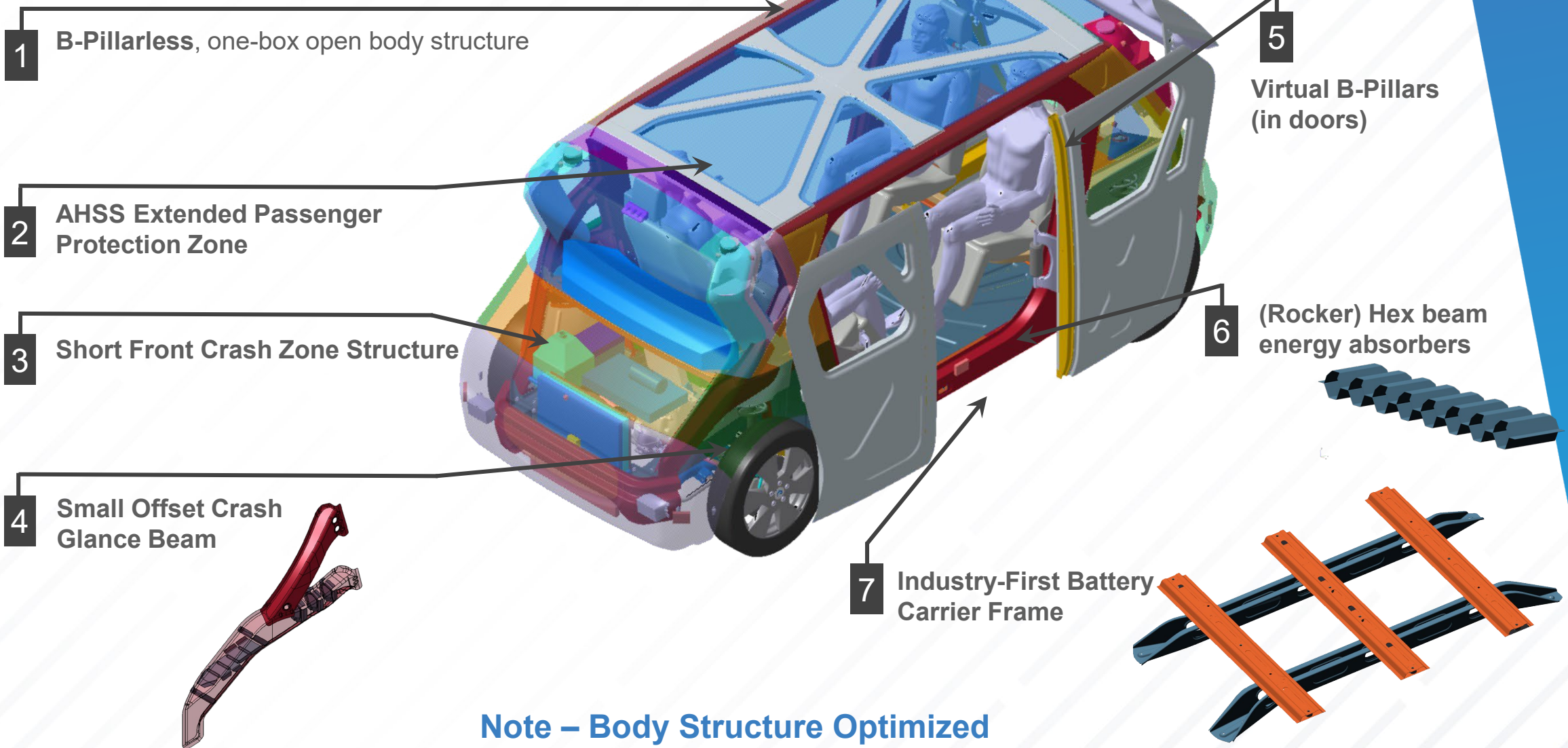

Note – Body Structure Optimized for Inward Facing Occupants

SEM1 Vehicle Cost Evaluation (Inputs)

SEM1 BoM Cost input

- MIT full vehicle costing tool developed for WorldAutoSteel's FutureSteelVehicle (FSV) program.
- Updates completed for Steel E-Motive program reflecting 2023 Steel grades / pricing.
- Costs defined for BIW, battery, bumper beams and closures (247 parts)

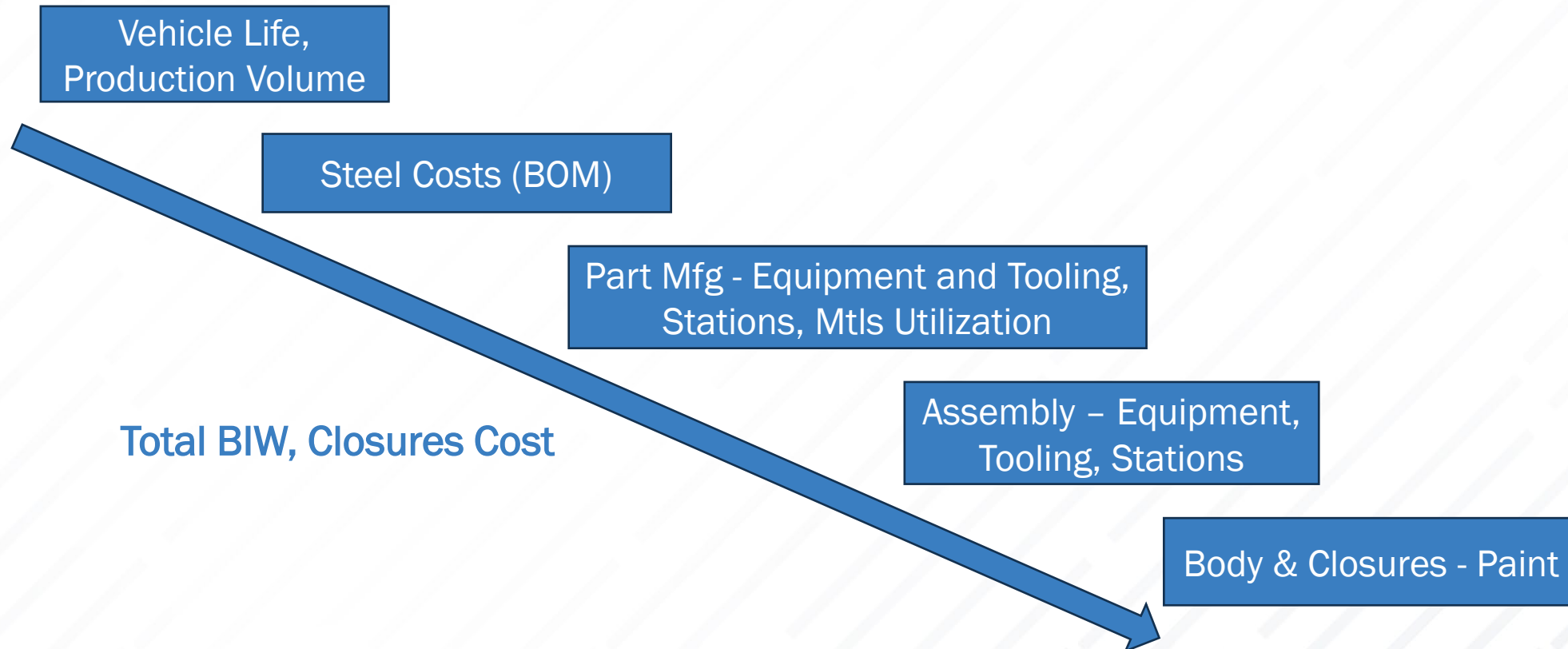

SEM1 BIW Part Costs

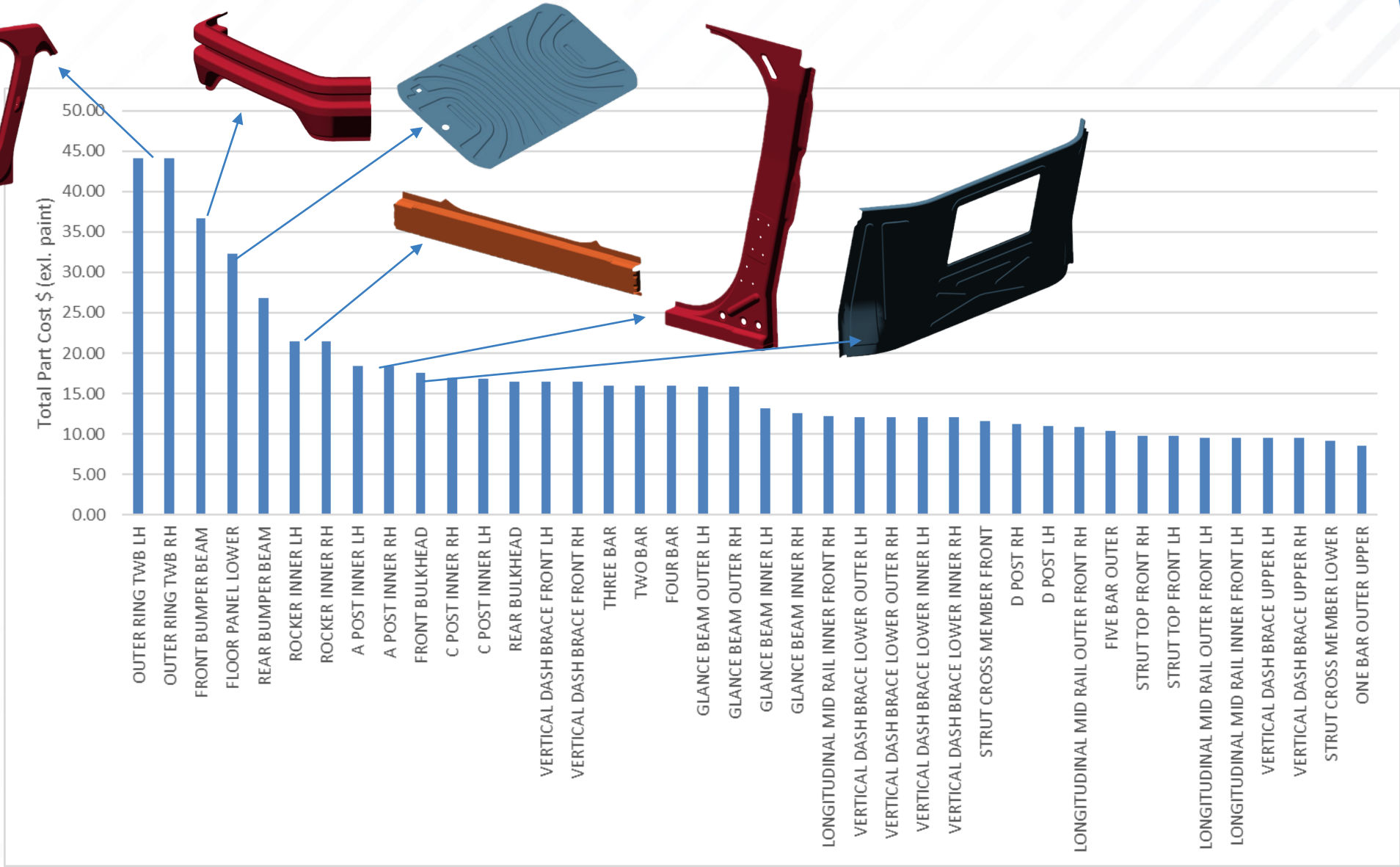

Engineered To Reduce Manufacturing Costs and TCO

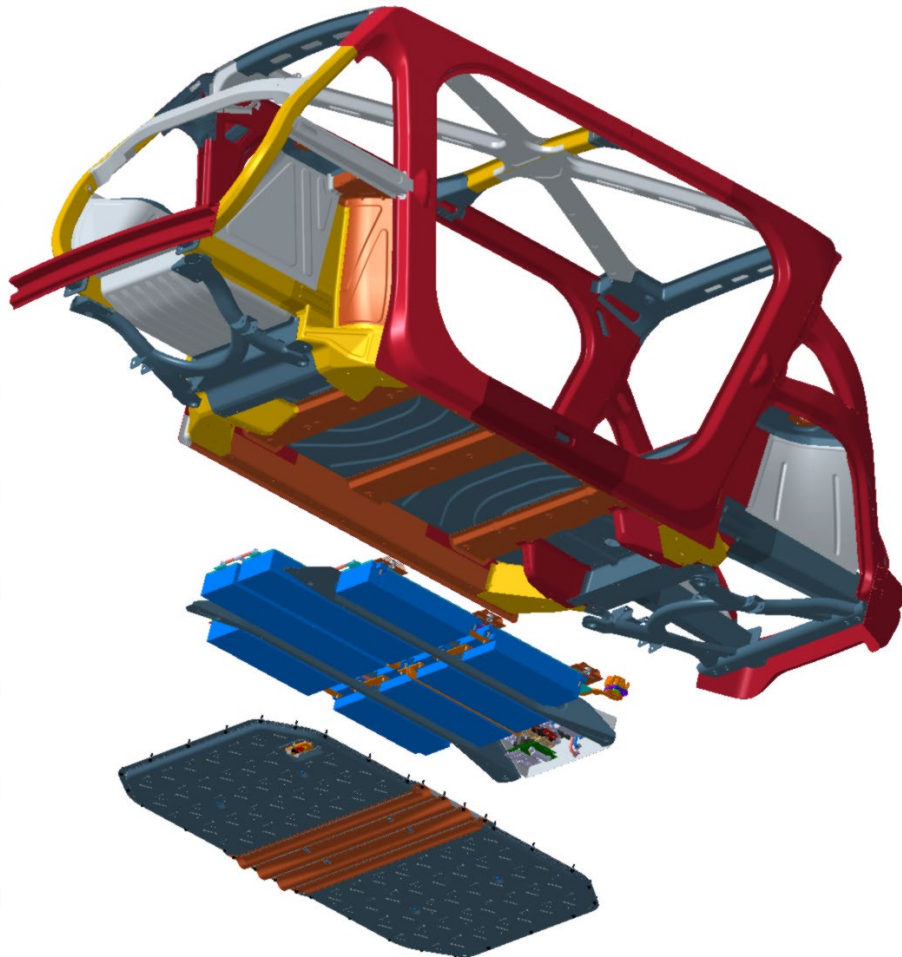

- Gauge optimization: overall thicknesses (1.2mm average)
- Expanded use of high material utilization processes (45%) – less material produced = lower costs
- Part integration (ex. TWB) and the elimination of body side outer and conventional B-Pillar
- Elimination of traditional battery box
- Production capable using existing manufacturing infrastructure

Total SEM1 BIW Cost - Projected vs. Actual (MIT Model Results)

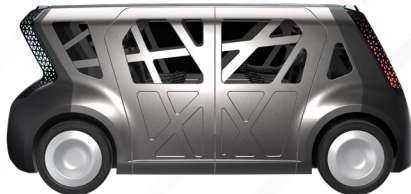

FutureSteelVehicle vs SEM1 BIW Cost (US\$)

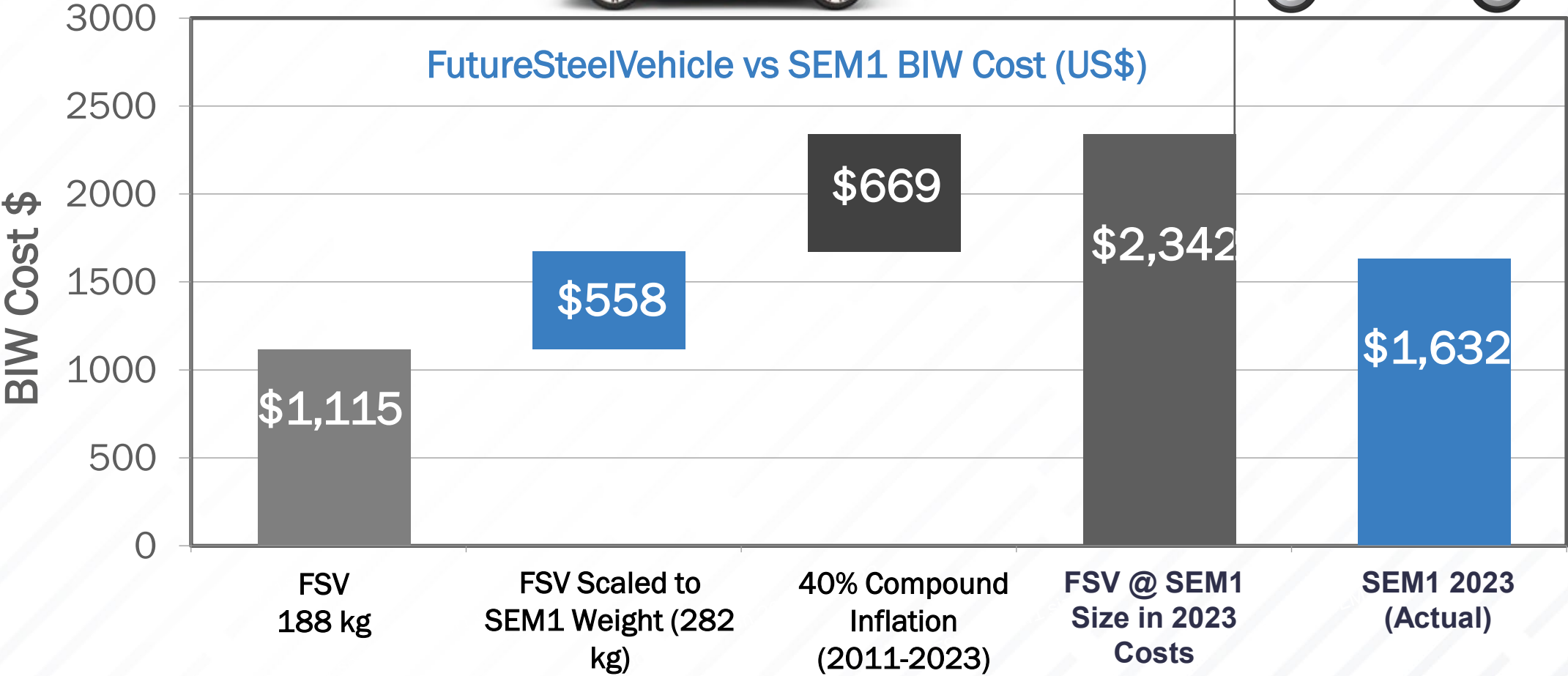

Steel E-Motive Life Cycle Assessment of Future Mobility Scenarios



Steel E-Motive Engineering Report

Figure 9.4.2 lifecycle analysis GHG CO₂ calculations (CO₂ equivalent per passenger-kilometers)

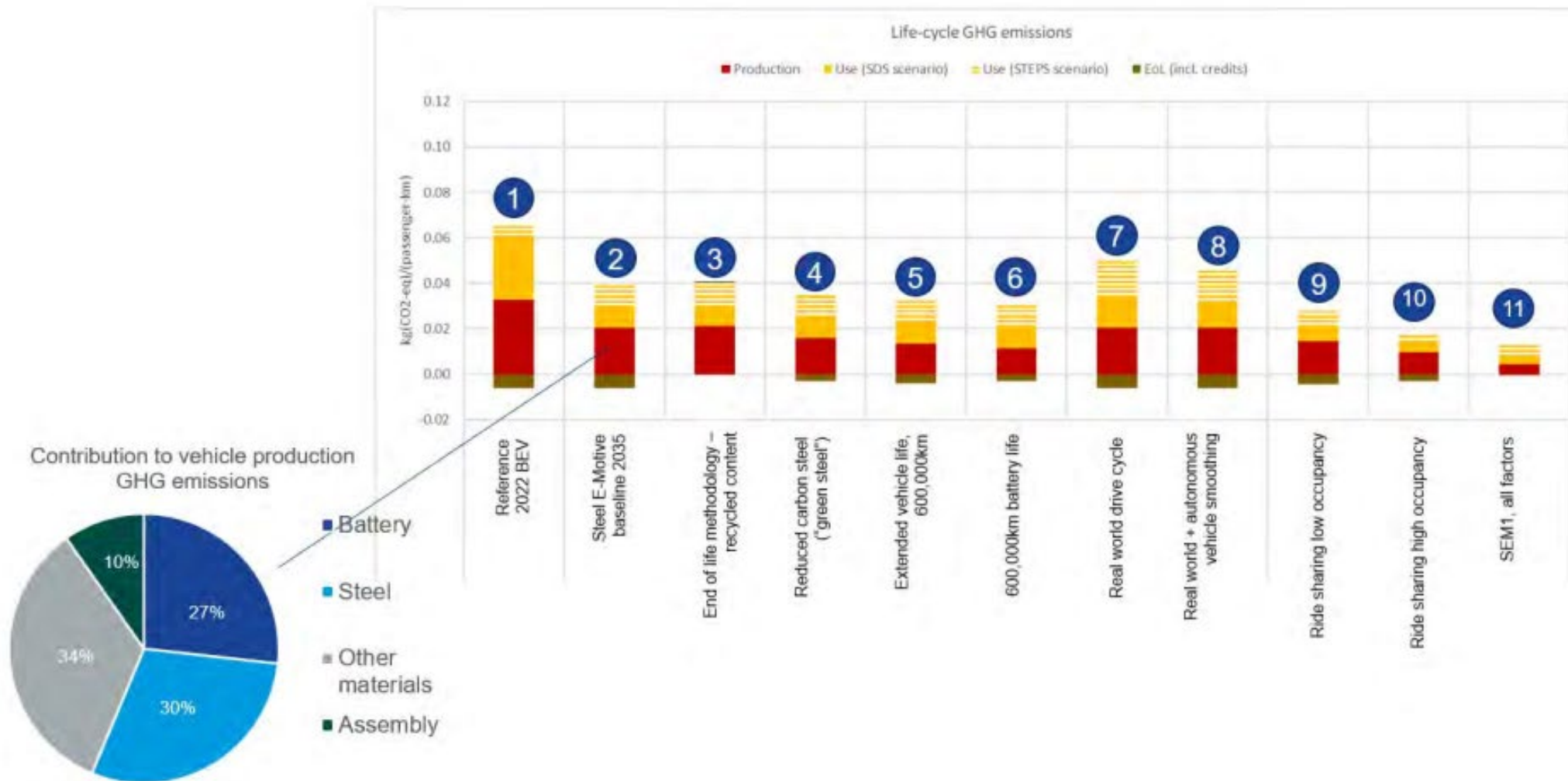

City of London and London Boroughs – Vehicle ‘Production Impacts’ – Sensitivity Scenarios

37% - 87% CO₂ savings based on EU Production scenario

2030

Year of Production

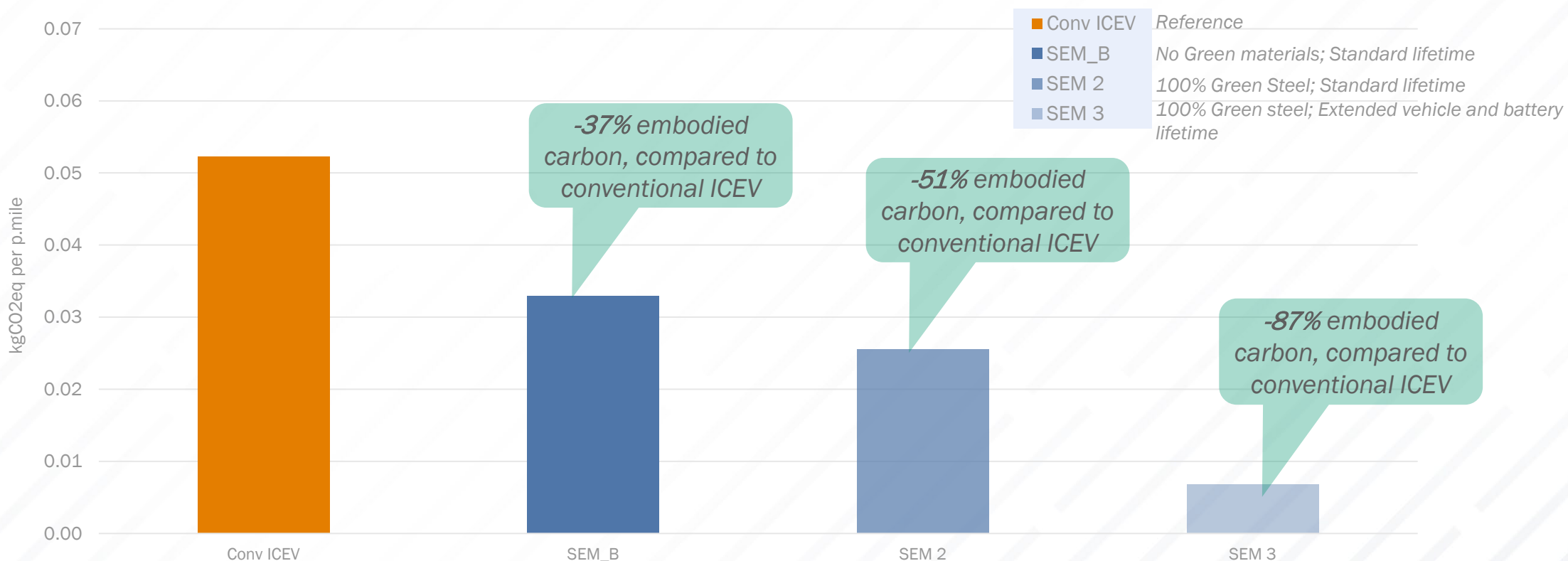

Source: Steel E-Motive Engineering Report, 2023 | Note: Maximum technical potential assumed for SEM scenarios

Setting the Net Zero scene: City of London and London boroughs

27 million TCO₂e

Overall GHG emissions in year 2021

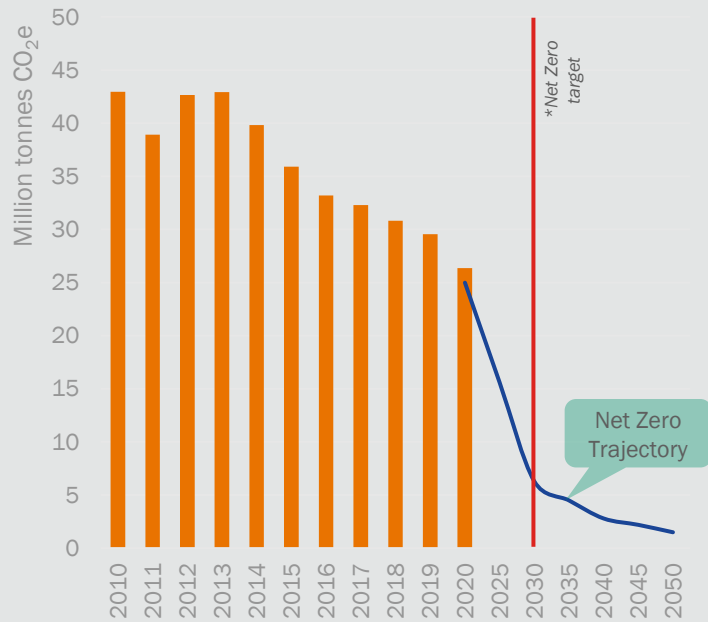

London Boroughs Net Zero by 2040 Target

6.6 million TCO₂e

Total Transport GHG emissions in year 2021,

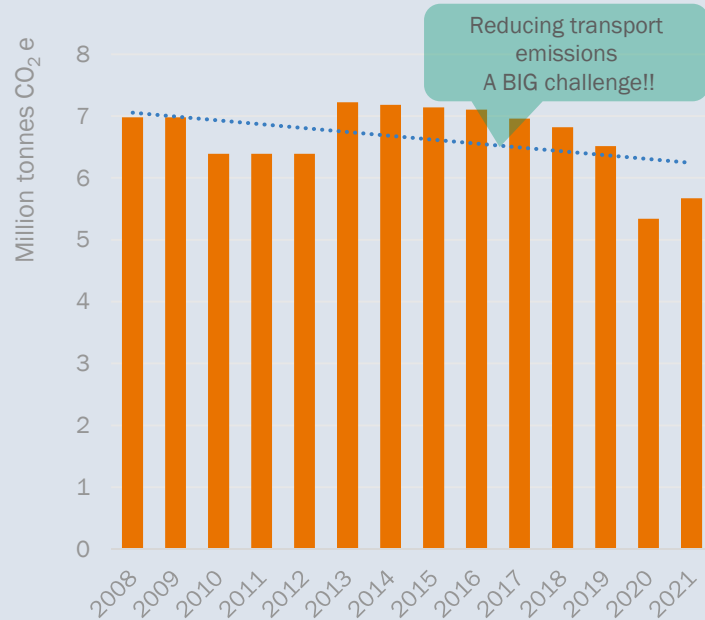

Reduction in transport emissions by 18.5% observed since 2008

5.6 million TCO₂e

Emissions from all road transport in year 2021

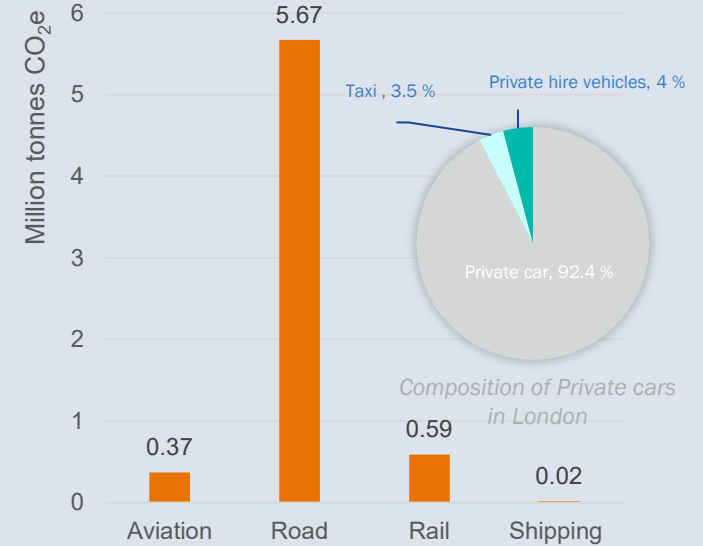

Cars alone contributed 52% of overall transport emissions. | Source: Department for Transport, UK, 2021

Source: Net Zero trajectory from [London Net Zero 2030 pathway, 2022](#)

GHG Savings from Steel-E Motive Concept Implementation – City of London and London boroughs

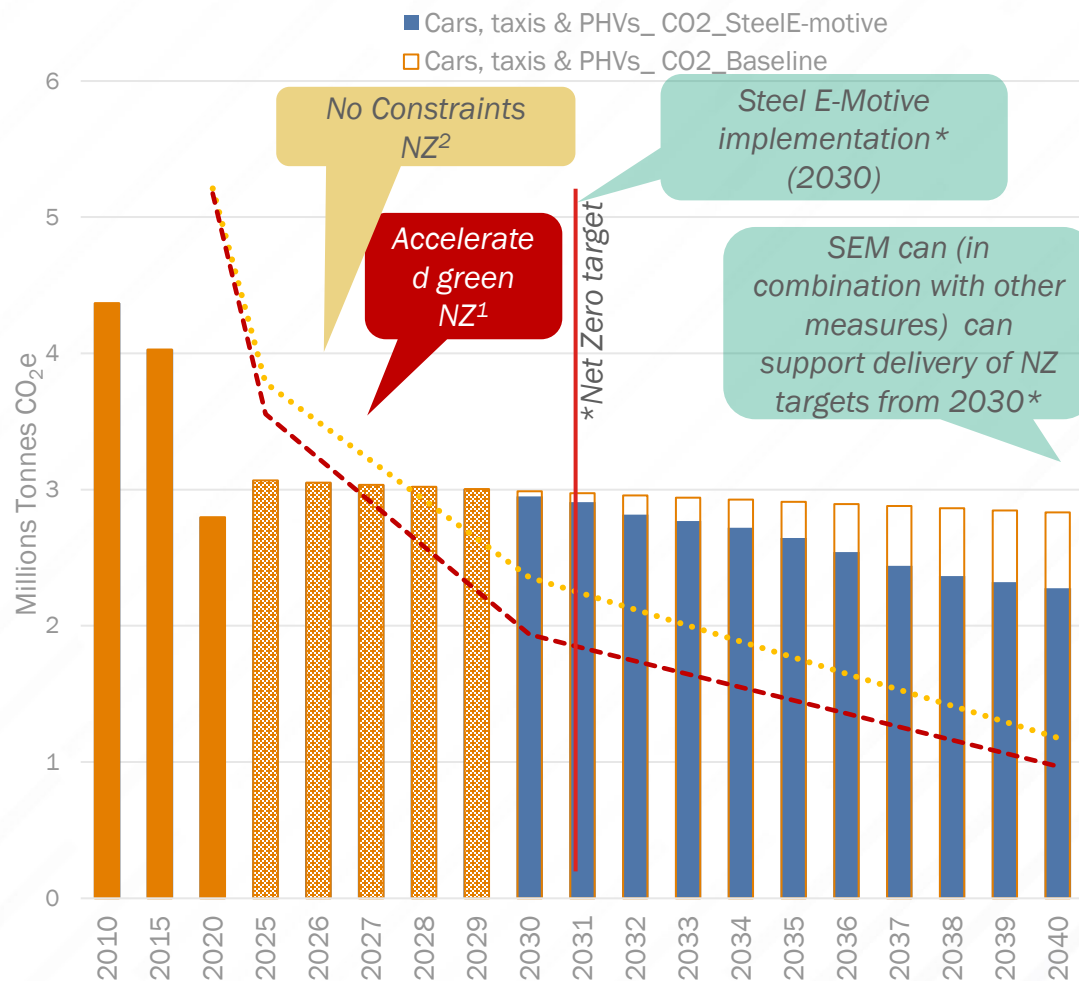

3.3 million TCO₂e
cumulative savings in Car, Taxi, PHVs emissions from roll out of Steel E-Motive from 2030-2024

¹ Accelerated NZ pathways: Reduction in car kms by 27% by 2030; Source Net Zero trajectory from [London Net Zero 2030 pathway, 2022](#)

² No Constraints NZ pathway: Reduction in car km by 40% by 2030; Source Net Zero trajectory from [London Net Zero 2030 pathway, 2022](#)

* Assuming variable annual SEM implementation rates and 20% new vehicle turnover rates.

City of London and London Boroughs – Vehicle ‘Use-case’ variations – Sensitivity Scenarios

3.2 to 7.4 million TCO₂e savings to Car, Taxis and PHVs CO₂ emissions after implementation of different “use-case” scenarios to Steel E-Motive implementation

2030-2040
Steel E-Motive Implementation

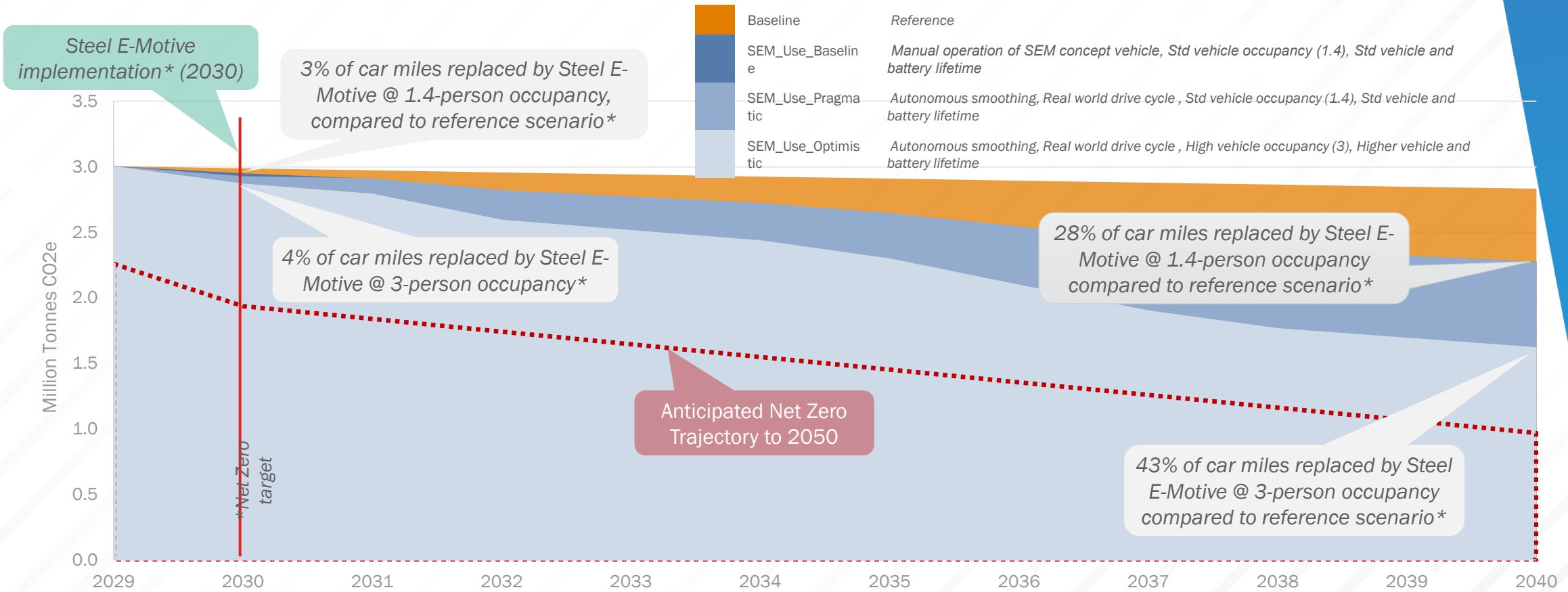

Scenario modelling assuming fixed rate of SEM vehicles replacing reference vehicles, which then should increasingly replace conv. ICEV miles (1.4x or 3x depending on occupancy rates of SEM) from 2030-2040 | Maximum technical potential assumed for scenarios | *Assuming variable annual SEM implementation rates, accounting for 20% of new vehicles.

Steel E-Motive – Summary

- The Steel E-Motive program has engineered innovative vehicle and body structure concepts for ride sharing, taking into consideration the freedoms and challenges offered by full autonomy
- Through application of the complete steel grade portfolio, the Steel E-Motive concept demonstrates:
 - Exceptional levels of occupant comfort, accessibility and safety
 - Cost-effective design, suitable for global high-volume production while leveraging existing manufacturing infrastructure
 - A clear path and contribution to net zero emissions

Engineering report freely available at <https://steelemotive.world> or here.



IN PARTNERSHIP WITH

