

Great Designs in

STEEL

Optimal Design Solutions for Two Side SORB using Bumper Design Space

(One Piece Design and Two Piece Design)

Rajasekaran Mohan

SMDI Bumper Group - Detroit Engineered Products



Scope Of the Project

- ❖ To study the IIHS 25% Small Overlap Rigid Barrier Impact (Driver and Passenger side) and Low Speed Performance of Baseline (Honda Accord Full Vehicle 2009) Model.
- ❖ Extend the Bumper outboard and design a Load Path to achieve the SORB performance for both Driver and Passenger side.
- ❖ Optimize the Bumper Section using Meshworks shape parameterization to achieve lighter design meeting the performance.
- ❖ To have alternative design with One Piece and Two Piece concepts meeting the targets.

Baseline Vehicle Performance

SORB Performance

Measurement Locations	Target (mm)	Baseline	
		Driver Side Hit	Passenger Side Hit
		Intrusion (mm)	Intrusion (mm)
Lower Hinge Pillar	<150	97.2	115
Foot Rest	<150	41.4	57.6
Toe Pan(Hit Side)	<150	45	57.1
Brake Pedal	<150	45.1	NA
Rocker Panel (Lateral)	<50	24.9	12.0
Steering Column (Longitudinal)	<50	17.9	3.7
Upper Hinge Pillar	<50	66.7	66
Upper Dash	<75	25.1	104
IP (Hit side)	<75	42.9	29.7

Baseline design is not meeting the 25% offset performance on

- ❖ Driver side at the Upper Hinge Pillar.
- ❖ Passenger side not meeting the Upper Hinge Pillar and the Upper Dash.

Baseline meets the Low Speed Impact performance ensuring the protection of adjacent subsystems

Low Speed Impact

Executive Summary	Baseline
Max Energy Bumper Can Absorb (J)	3115.8
Bumper Beam Force (kN)	19.34
Other Subsystems Damage Protection During Impact	No damage to Hood and CRFM

Background - Bumper Load Path Study

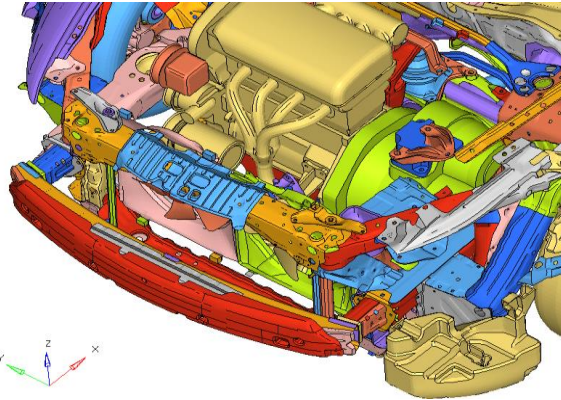

- ❖ Initial Load path assessment was performed with various Load path concepts like blocker inline with the SORB Barrier and angled connecting to the Rails.
- ❖ Iterations concluded directionally that the Inline Blocker performing better for the SORB performance.
- ❖ Angled blocker kinks the rails and not achieving the desirable energy absorption in the initial stage of the crash event.

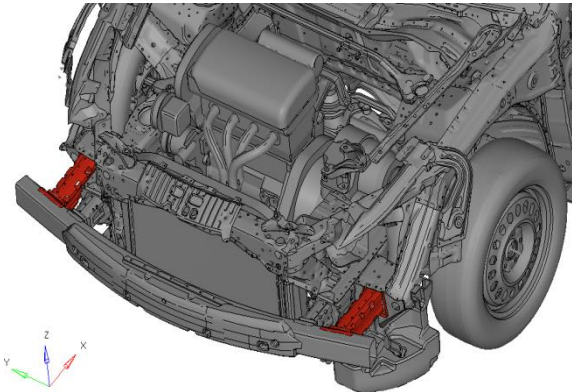

Barrier Inline Load Path

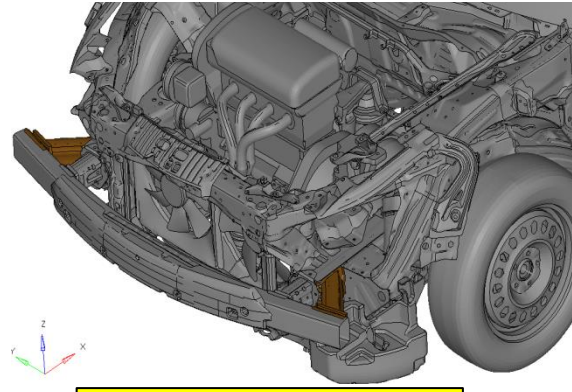

Barrier Inclined Load Path

Bumper Design - Packaging

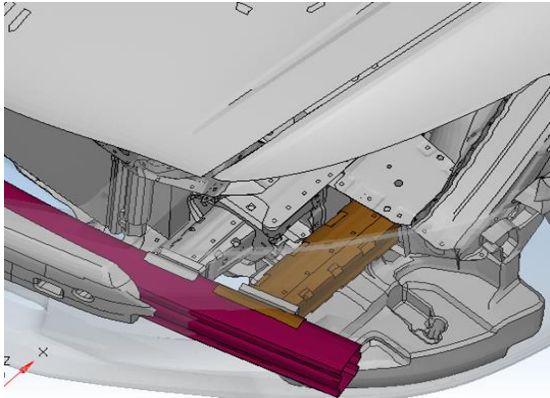
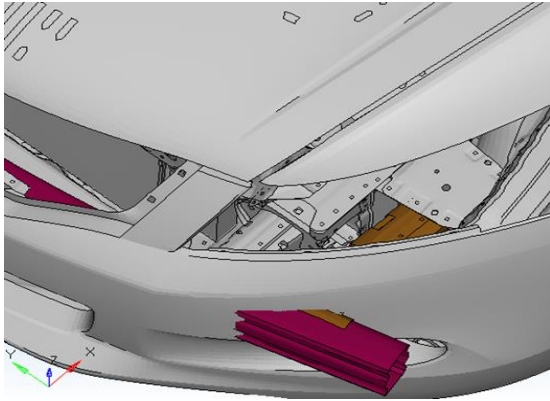

- ❖ Bumper Beam design was extended to the Design Space in the initial assessment.
- ❖ Bumper concept was morphed and packaged into the Fascia design.

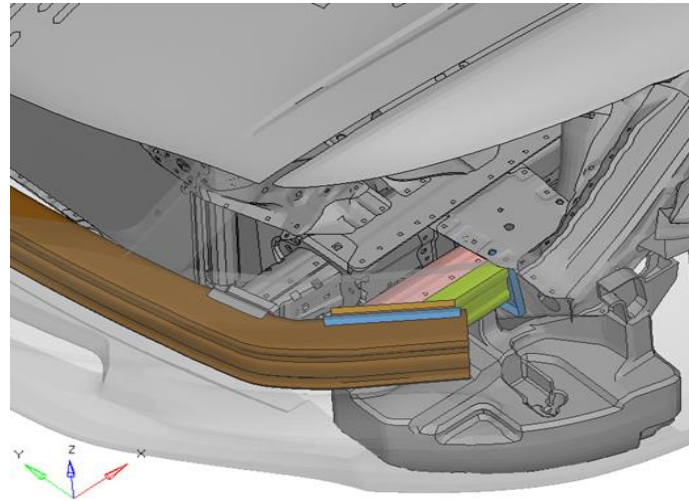

Bumper Beam Section Parameterization

All Dimensions are in mm

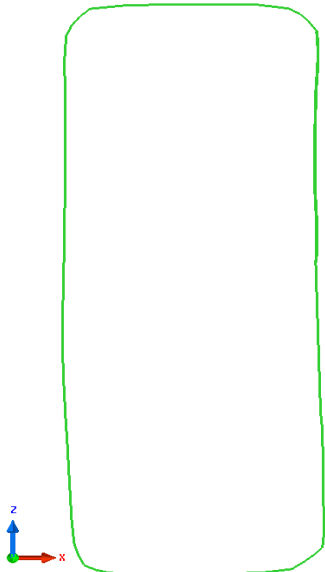

Bumper Section Morphing

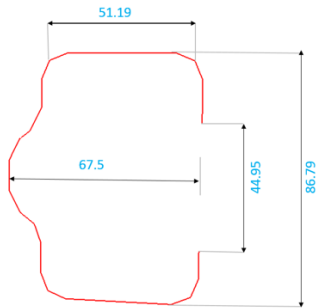

Baseline

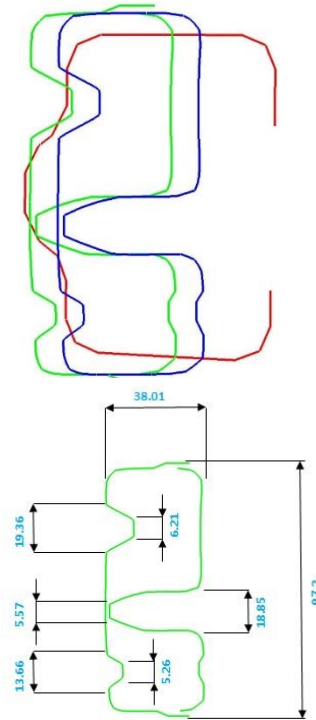

Two Piece

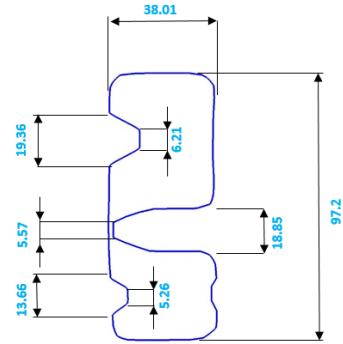

One Piece

Baseline
Two Piece
One Piece

Bumper Top View Comparison

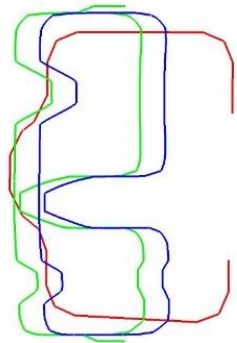

Section View

Baseline

Two Piece

One Piece

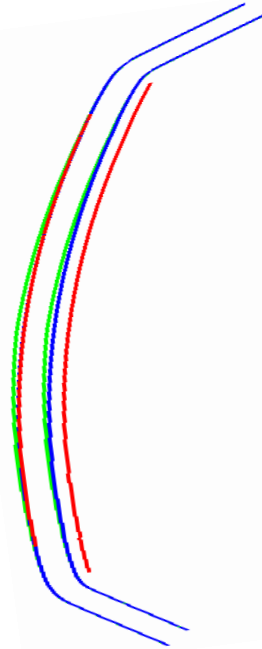

Overlay Plot



Baseline

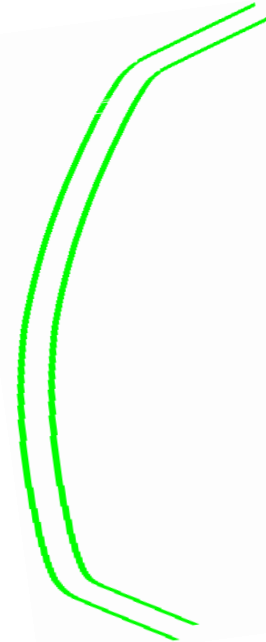

Two Piece

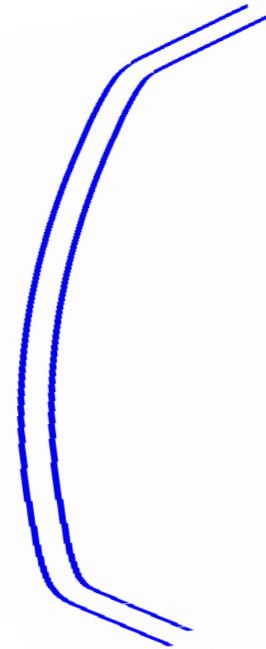

One Piece

Small Overlap Rigid Barrier Impact (Driver and Passenger Side)

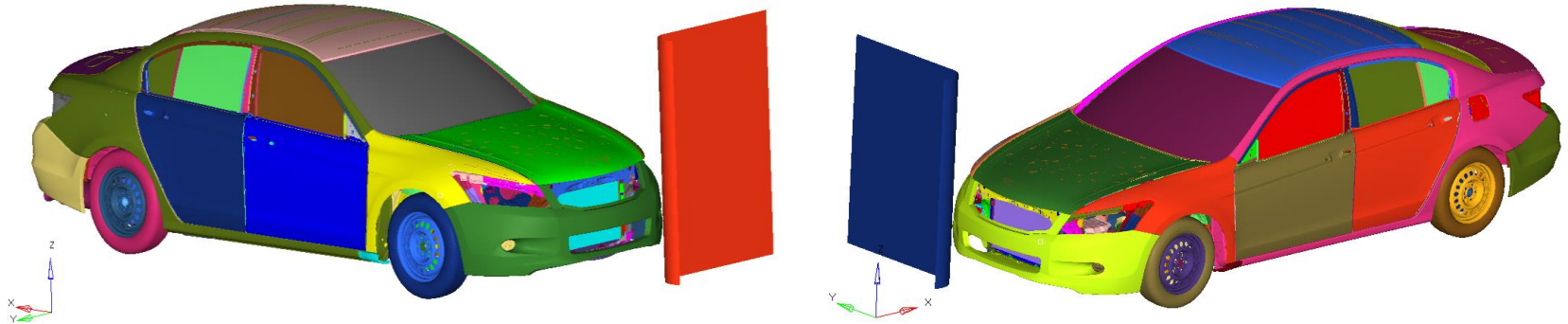

25 % SORB Model Setup

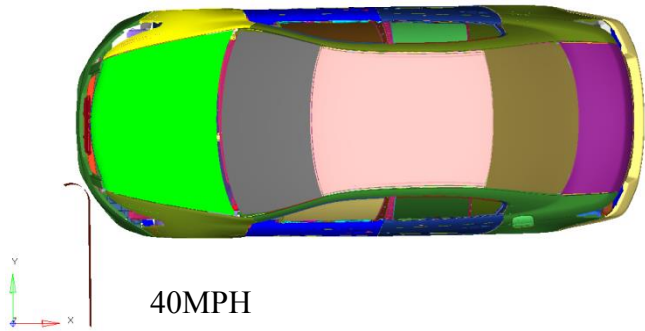

Driver Side

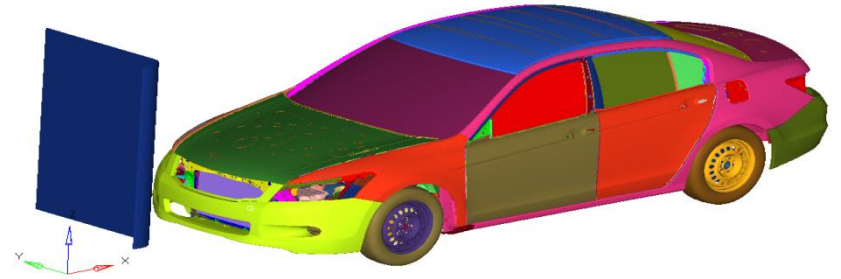
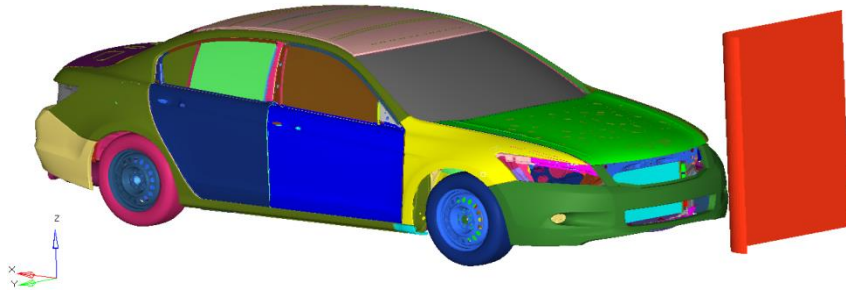
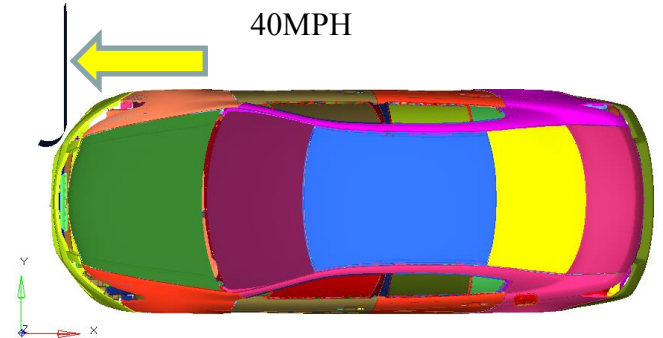

Passenger Side

Animations – ISO View

Baseline - Driver

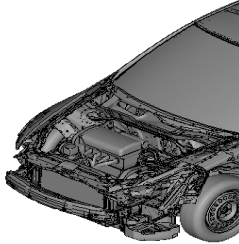

Two Piece Driver

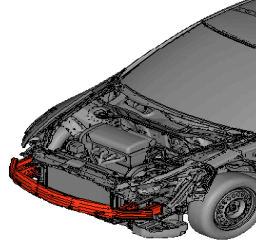

One Piece Driver

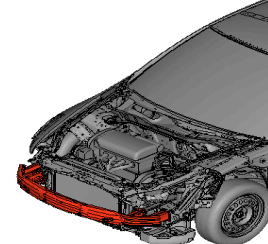

Baseline - Passenger

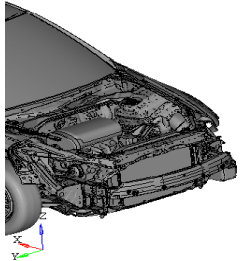

Two Piece Passenger

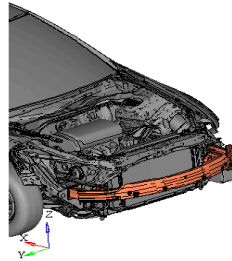

One Piece Passenger

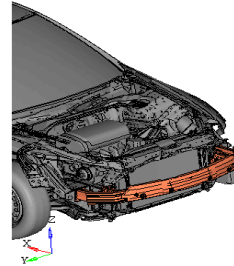

- ❖ Bumper extension engages the SORB Barrier and absorbs Energy in initial stage of the Crash event in both the Designs

IIHS 25 % SMALL OVERLAP RIGID BARRIER RESULTS PASSENGER SIDE IMPACT

Intrusion Plots - Passenger Side Impact

Upper Hinge Pillar

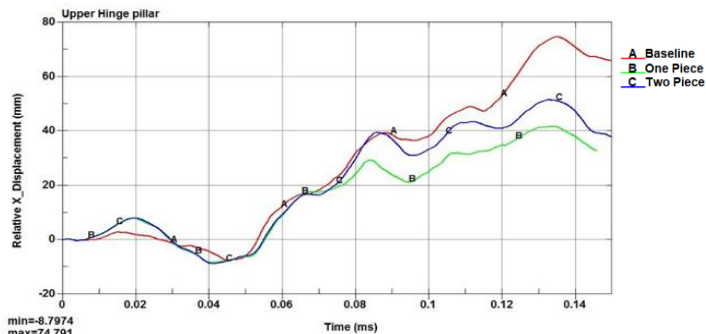

Upper Dash

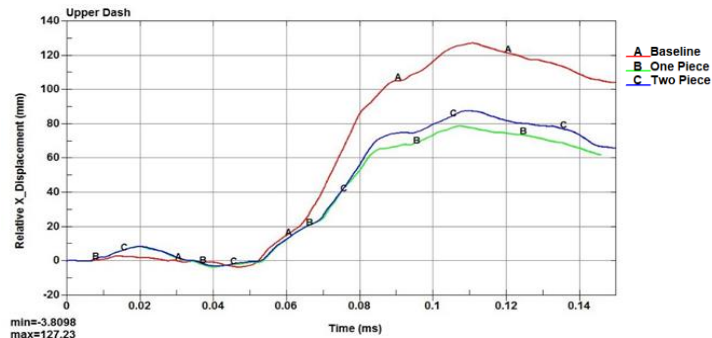

Measurement Locations	Target (mm)	Passenger Side Hit		
		Baseline	One Piece Design	Two Piece Design
		Intrusion (mm)	Intrusion (mm)	Intrusion (mm)
Upper Hinge Pillar	<50	66	32	38.1
Upper Dash	<75	104	63	65.8

Intrusions in the upper hinge pillar and dash have reduced meeting the targets as per SORB performance

Intrusion Plots - Passenger Side Impact

Lower Hinge Pillar

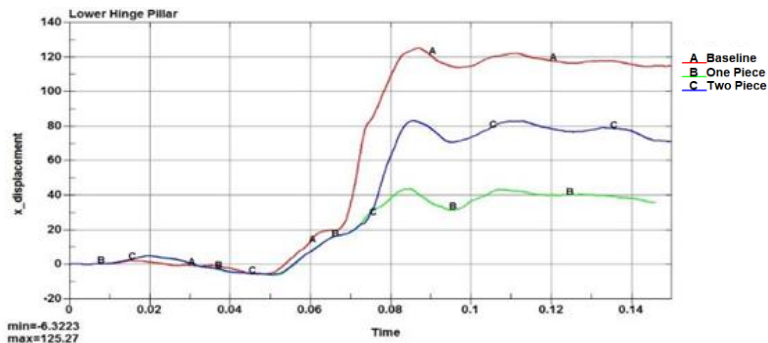

Steering Column

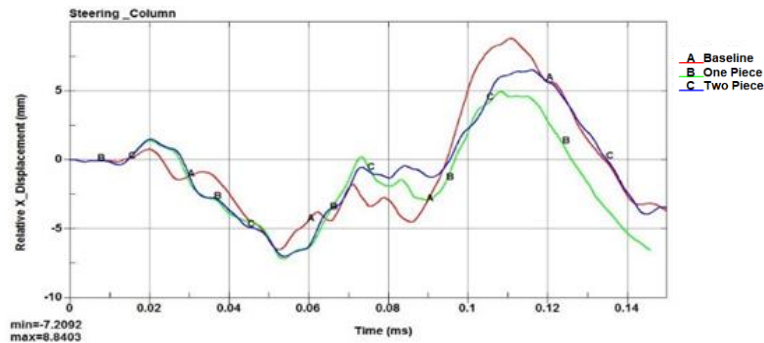

Measurement Locations	Target (mm)	Passenger Side Hit		
		Baseline	One Piece Design	Two Piece Design
		Intrusion (mm)	Intrusion (mm)	Intrusion (mm)
Lower Hinge Pillar	<150	115	35.7	71.2
Steering Column (Longitudinal)	<50	3.7	6.48	3.48

Intrusion Plots - Passenger Side Impact

Foot Rest

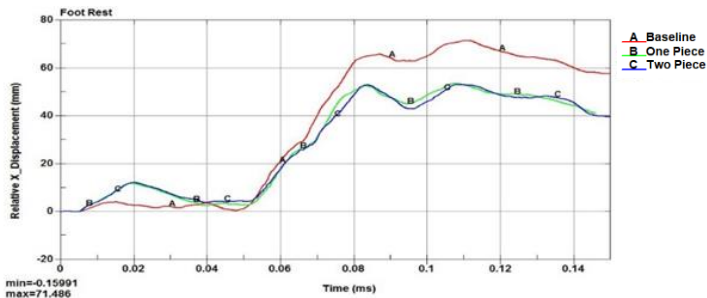

Right Toe Pan

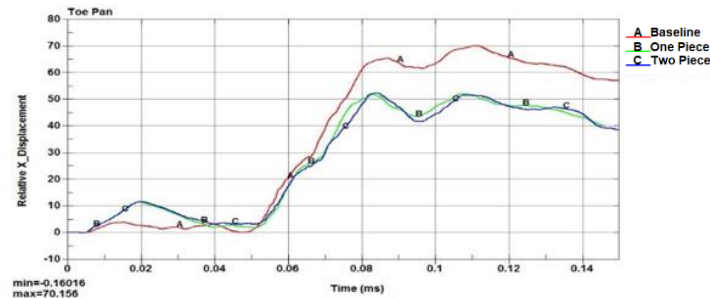

Measurement Locations	Target (mm)	Passenger Side Hit		
		Baseline	One Piece Design	Two Piece Design
		Intrusion (mm)	Intrusion (mm)	Intrusion (mm)
Foot Rest	<150	57.6	40.5	39.6
Toe Pan(Hit Side)	<150	57.1	40.3	38.8

Intrusion Plots - Passenger Side Impact

Right IP

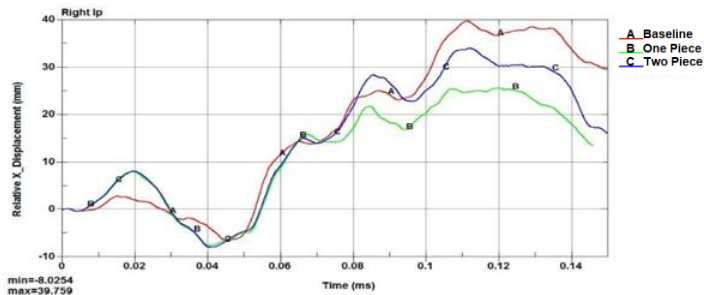

Rocker panel

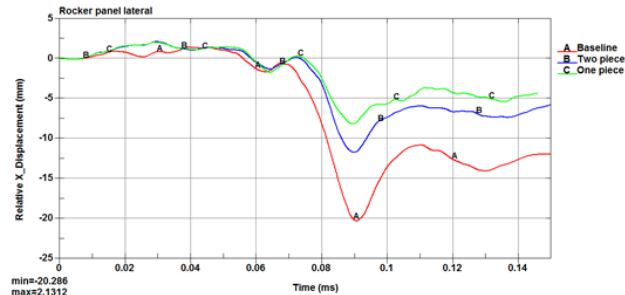

Measurement Locations	Target (mm)	Passenger Side Hit		
		Baseline	One Piece Design	Two Piece Design
		Intrusion (mm)	Intrusion (mm)	Intrusion (mm)
IP (Hit side)	<75	29.7	13.6	16.4
Rocker Panel (Lateral)	<50	12	4.3	5.8

IIHS 25 % SMALL OVERLAP RIGID BARRIER RESULTS DRIVER SIDE IMPACT

Intrusion Plots- Driver side impact

Upper Hinge Pillar

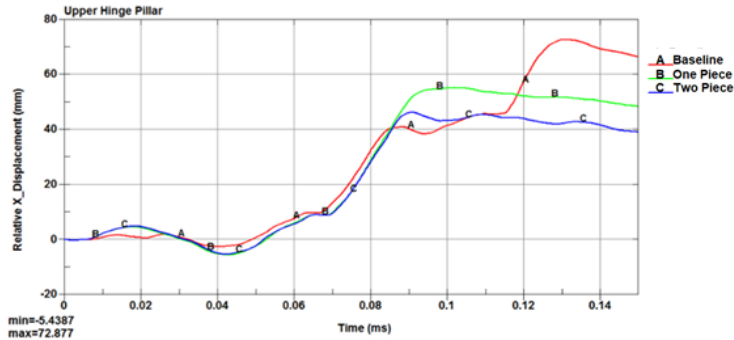

Upper Dash

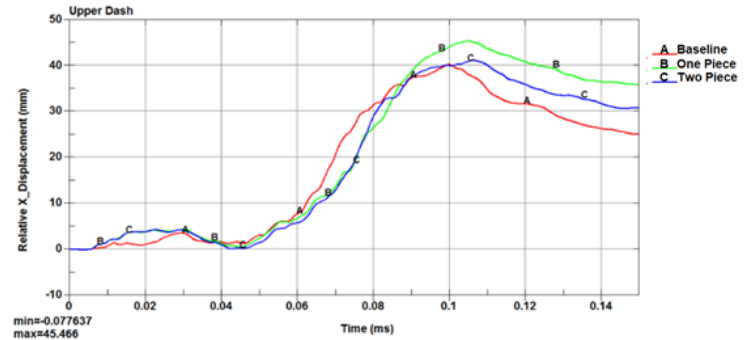

Measurement Locations	Target (mm)	Driver Side Hit		
		Baseline	One Piece Design	Two Piece Design
		Intrusion (mm)	Intrusion (mm)	Intrusion (mm)
Upper Hinge Pillar	<50	66.7	48.6	39.4
Upper Dash	<75	25.1	36	38.9

Intrusions in the upper hinge pillar and dash have reduced meeting the targets as per SORB performance

Intrusion Plots- Driver side impact

Brake Pedal

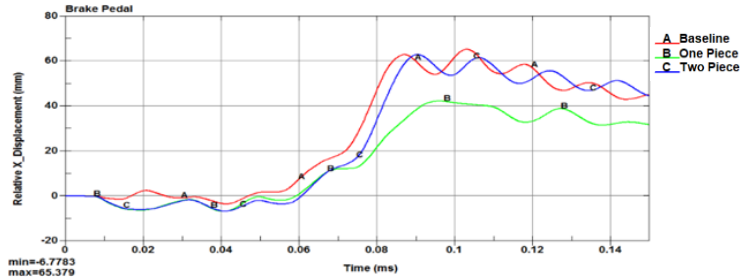

Lower Hinge Pillar

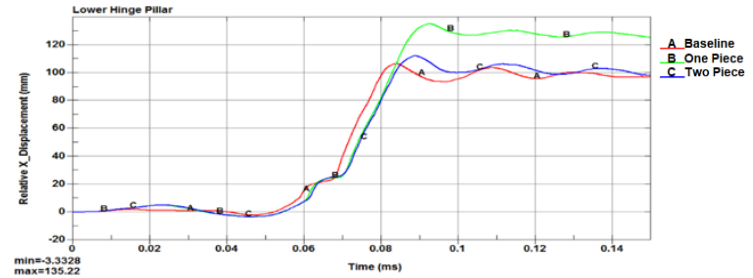

Measurement Locations	Target (mm)	Driver Side Hit		
		Baseline	One Piece Design	Two Piece Design
		Intrusion (mm)	Intrusion (mm)	Intrusion (mm)
Lower Hinge Pillar	<150	97.2	126	98.4
Brake Pedal	<150	45.1	32	45.2

Intrusion Plots - Driver side impact

Foot Rest

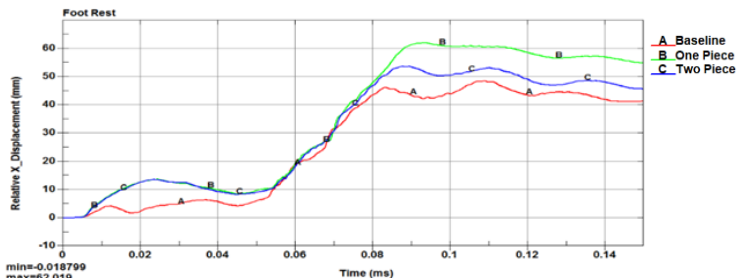

Left Toe Pan

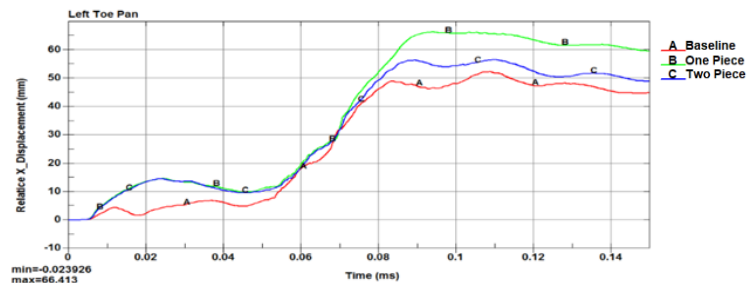

Measurement Locations	Target (mm)	Driver Side Hit		
		Baseline	One Piece Design	Two Piece Design
		Intrusion (mm)	Intrusion (mm)	Intrusion (mm)
Foot Rest	<150	41.4	54.9	45.7
Toe Pan(Hit Side)	<150	45	59.7	48.1

Intrusion Plots - Driver side impact

Rocker Panel

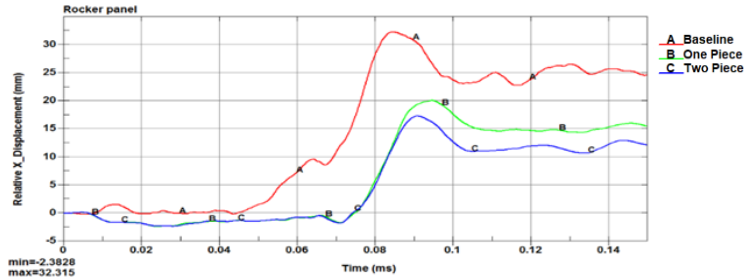

Steering Column

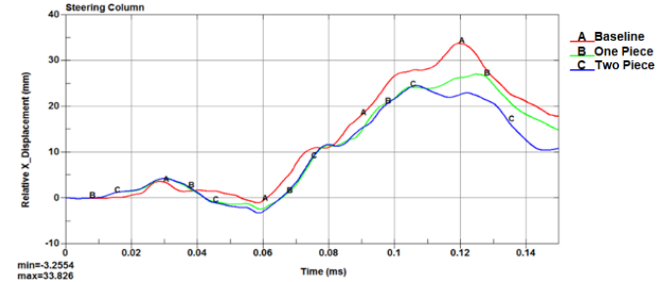

Measurement Locations	Target (mm)	Driver Side Hit		
		Baseline	One Piece Design	Two Piece Design
		Intrusion (mm)	Intrusion (mm)	Intrusion (mm)
Rocker Panel (Lateral)	<50	24.9	15.6	12.2
Steering Column (Longitudinal)	<50	17.9	15.1	10.8

Intrusion Plots - Driver side impact

Left IP

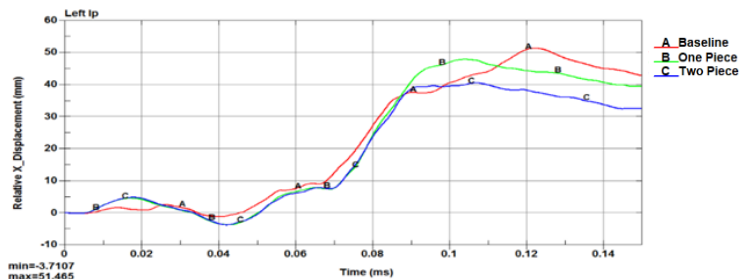

Measurement Locations	Target (mm)	Driver Side Hit		
		Baseline	One Piece Design	Two Piece Design
		Intrusion (mm)	Intrusion (mm)	Intrusion (mm)
IP (Hit side)	<75	42.9	39.6	32.6

25 % SORB Performance

Measurement Locations	Target (mm)	Baseline		One Piece Design		Two Piece Design	
		Driver Side Hit	Passenger Side Hit	Driver Side Hit	Passenger Side Hit	Driver Side Hit	Passenger Side Hit
		Intrusion (mm)	Intrusion (mm)	Intrusion (mm)	Intrusion (mm)	Intrusion(mm)	Intrusion (mm)
Lower Hinge Pillar	<150	97.2	115	126	35.7	98.4	71.2
Foot Rest	<150	41.4	57.6	54.9	40.5	45.7	39.6
Toe Pan(Hit Side)	<150	45	57.1	59.7	40.3	48.1	38.8
Brake Pedal	<150	45.1	NA	32	NA	45.2	NA
Rocker Panel (Lateral)	<50	24.9	12.0	15.6	4.3	12.2	5.82
Steering Column (Longitudinal)	<50	17.9	3.7	15.1	6.48	10.8	3.48
Upper Hinge Pillar	<50	66.7	66	48.6	38	39.4	38.1
Upper Dash	<75	25.1	104	36	63	38.9	65.8
IP (Hit side)	<75	42.9	29.7	39.6	13.6	32.6	16.6

- ❖ Both One Piece and Two Piece designs have met the targets for the 25% SORB Performance on both Passenger and Driver side Impact.

Low Speed Impact

Low Speed Impact Setup

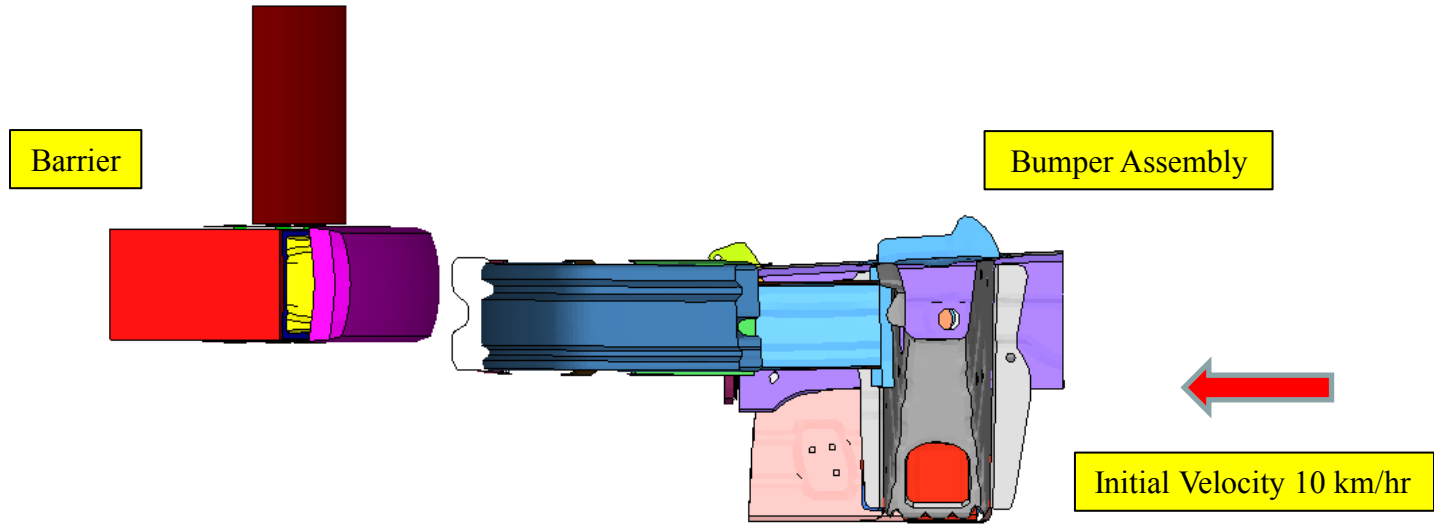

- ❖ Vehicle Curb mass of 1679 kg was considered for the Low Speed Impact Simulation.
- ❖ Vehicle X-velocity of 10 km/hr was applied to the model.

Full Vehicle – Low Speed - Animation

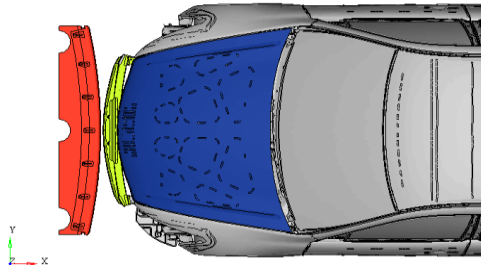

Baseline

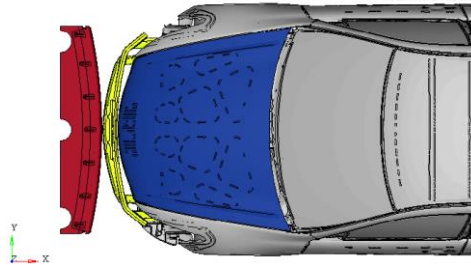

Two Piece

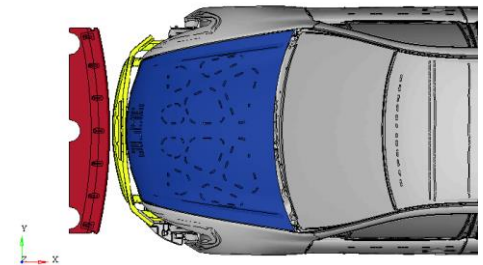

One Piece

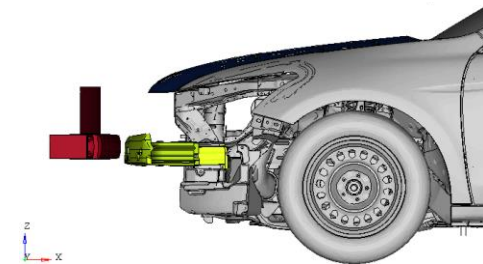
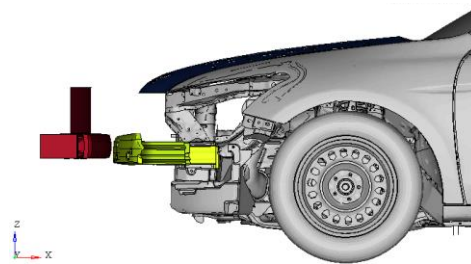
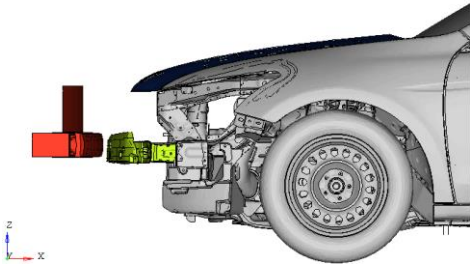

- ❖ Low speed full vehicle simulation shows that the bumper protects the Hood with out any damage, managing all the energy during the Low speed impact.

Bumper Deflection Plot

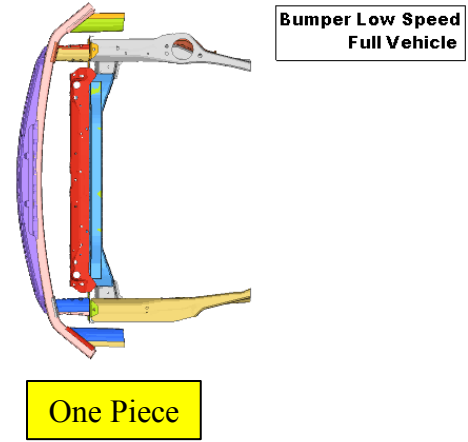
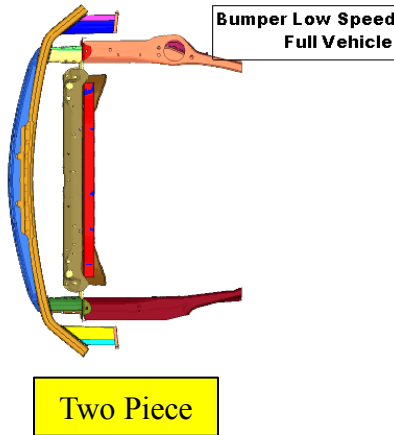
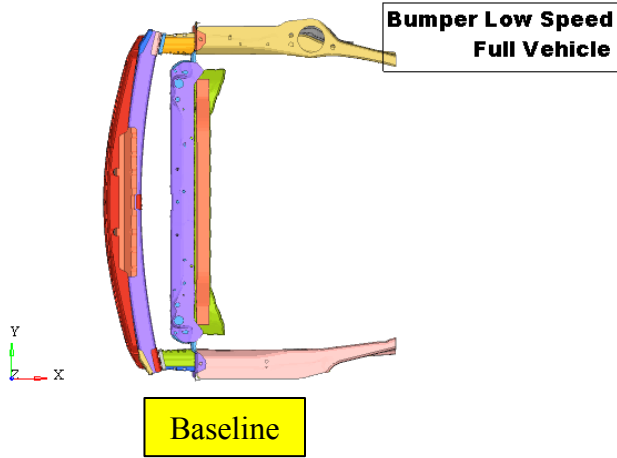

Bumper Deflection Plot

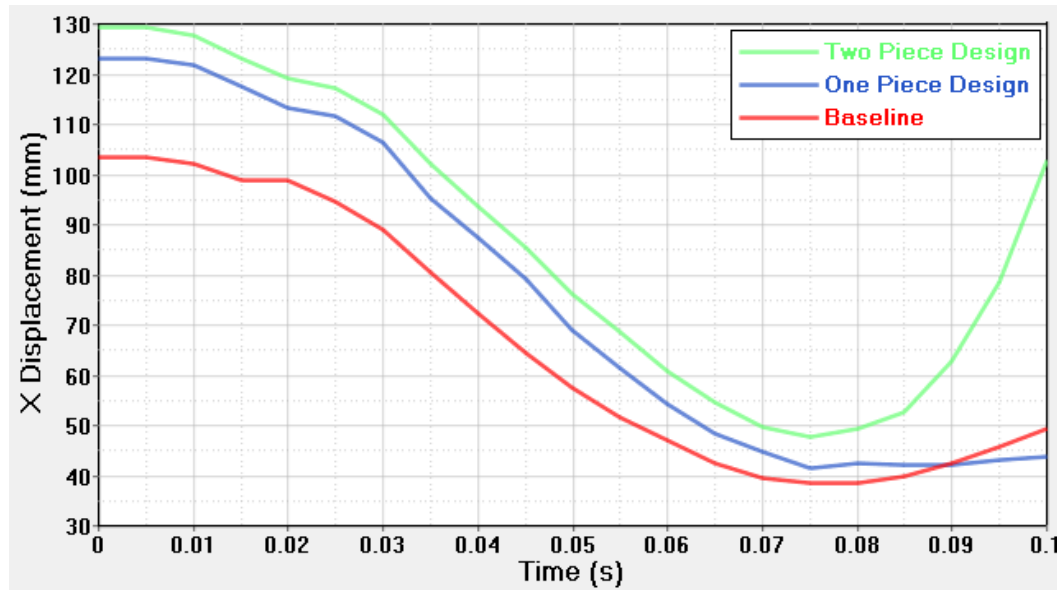

- ❖ A clearance of 42mm and 47.5mm were maintained between the bumper maximum intrusion location and the CRFM assembly for the One Piece and Two Piece design respectively.
- ❖ In both designs Bumper protects the CRFM without any damage.

Strain Plots – Bumper Beam – One Piece Design

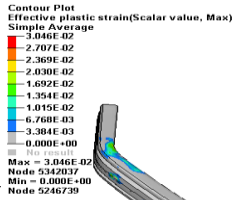
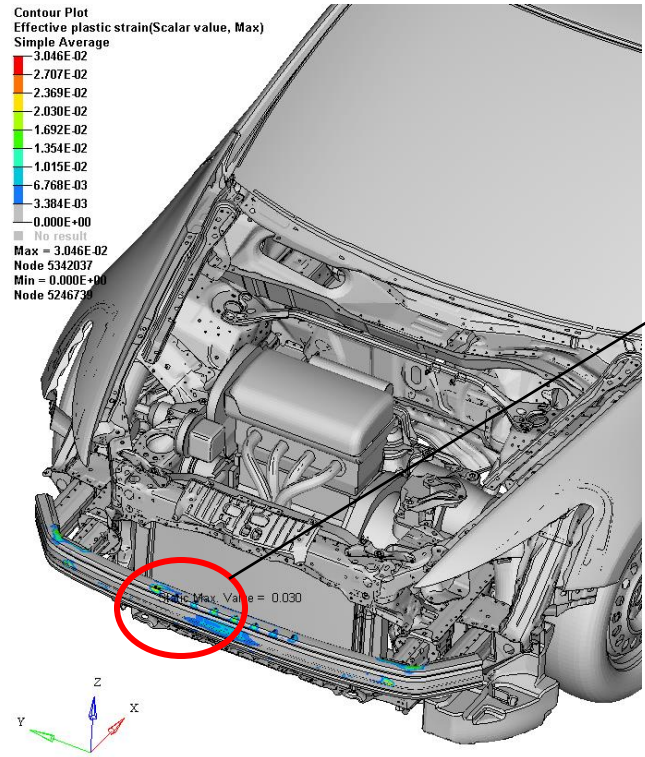

Max Plastic Strain on Bumper Design – 3.1%

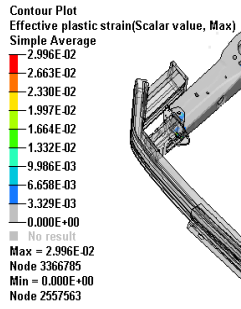

Max Plastic Strain on Front Rail – 2.9%

Strain Plots – Bumper Beam – Two Piece Design

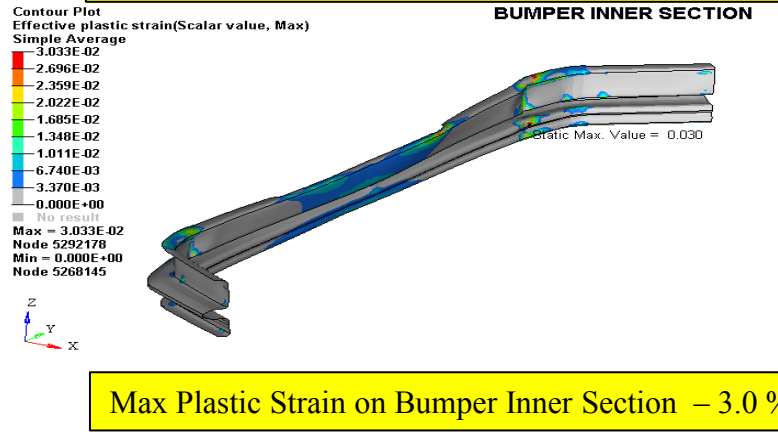
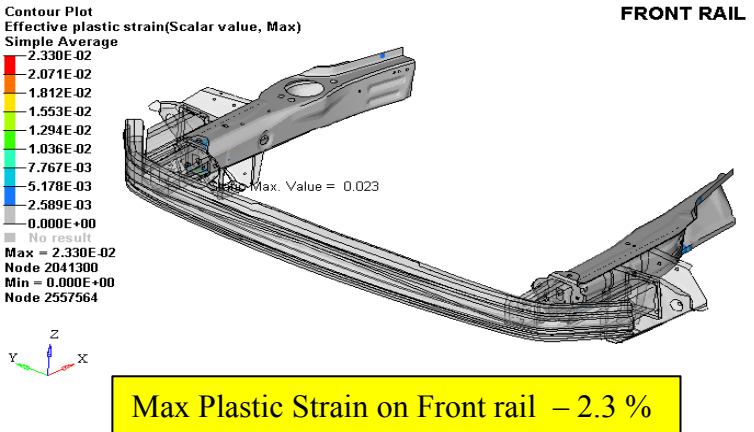
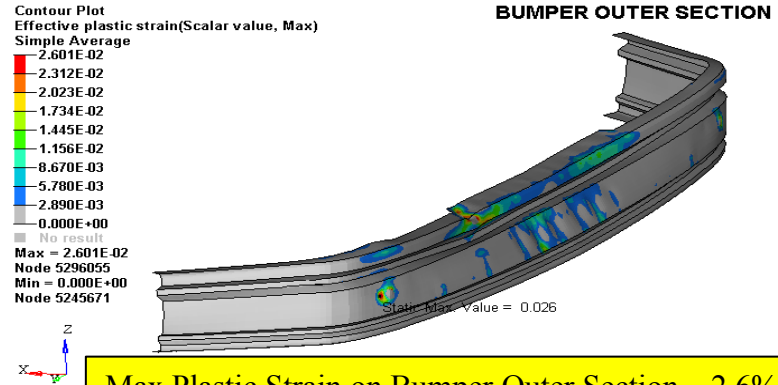
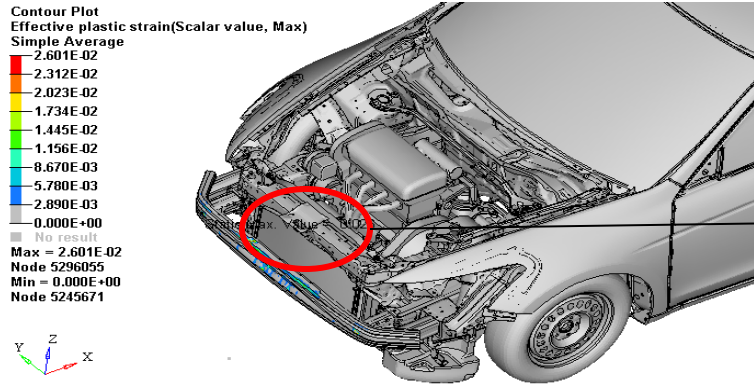

LOW SPEED IMPACT (Bumper Sub-Assembly Level)

Bumper Low Speed Impact Performance

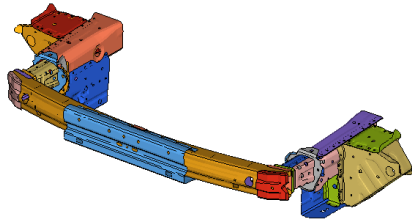
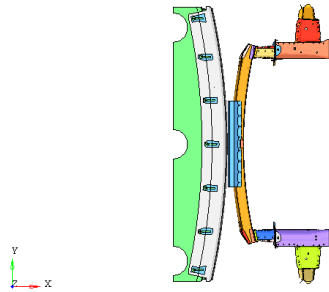

Baseline

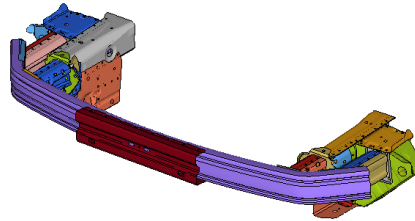
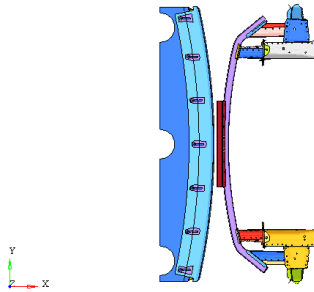

One Piece

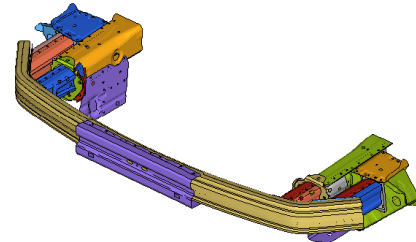
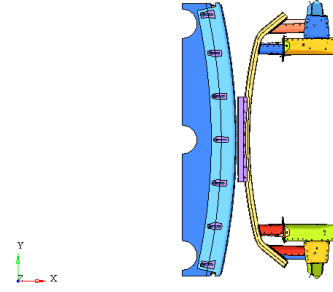

Two Piece

Bumper Low Speed Impact Performance

Executive Summary	Baseline	One Piece	Two Piece
Max Energy Bumper Can Absorb (kJ)	3115.8	3700.3	3616.5
Bumper Beam Force (kN)	19.34	16.41	16.06

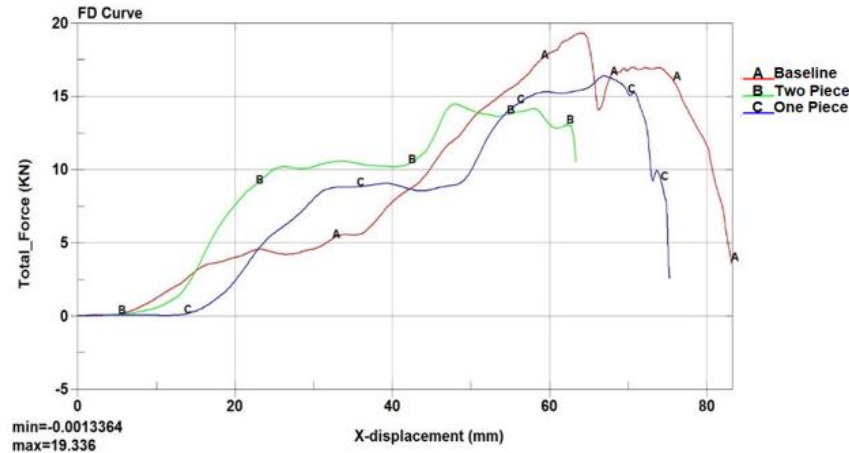

Force vs Deflection Curve

Executive Summary – Two Piece Design Performance

SORB Performance	Measurements	Target (mm)	Baseline		One Piece Design		Two Piece Design	
			Driver Side Hit	Passenger Side Hit	Driver Side Hit	Passenger Side Hit	Driver Side Hit	Passenger Side Hit
			Intrusion (mm)	Intrusion (mm)	Intrusion (mm)	Intrusion (mm)	Intrusion (mm)	Intrusion (mm)
	Lower Hinge Pillar	<150	97.2	115	126	70	98.4	71.2
	Foot Rest	<150	41.4	57.6	54.9	42	45.7	39.6
	Toe Pan(Hit Side)	<150	45	57.1	59.7	38	48.1	38.8
	Brake Pedal	<150	45.1	NA	32	NA	45.2	NA
	Rocker Panel (Lateral)	<50	24.9	12.0	15.6	6	12.2	5.82
	Steering Column (Longitudinal)	<50	17.9	3.69	15.1	3	10.8	3.48
	Upper Hinge Pillar	<50	66.7	66	48.6	38	39.4	38.1
	Upper Dash	<75	25.1	104	36	63	38.9	65.8
	IP (Hit side)	<75	42.9	29.7	39.6	16	32.6	16.6

Low Speed Impact	Measurements	Baseline	One Piece Design	Two Piece Design
	Max Energy Bumper Can Absorb (J)	3115.8	3700.3	3616.5
	Bumper Beam Force (kN)	19.34	16.41	16.06
	Other Subsystems Damage Protection During Impact	No damage to Hood and CRFM	No damage to Hood and CRFM	No damage to Hood and CRFM

Bumper Design- One Piece Design

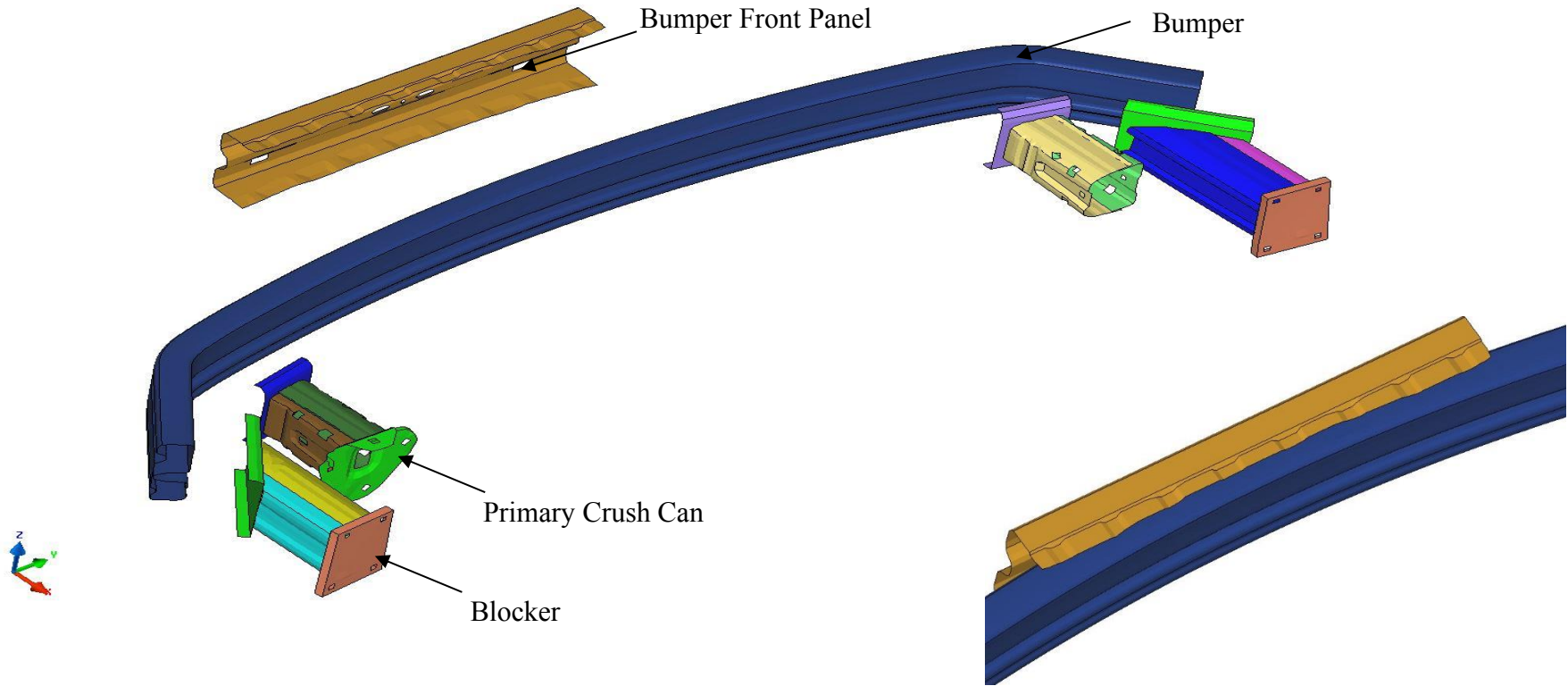

Bumper Design – Two Piece Design

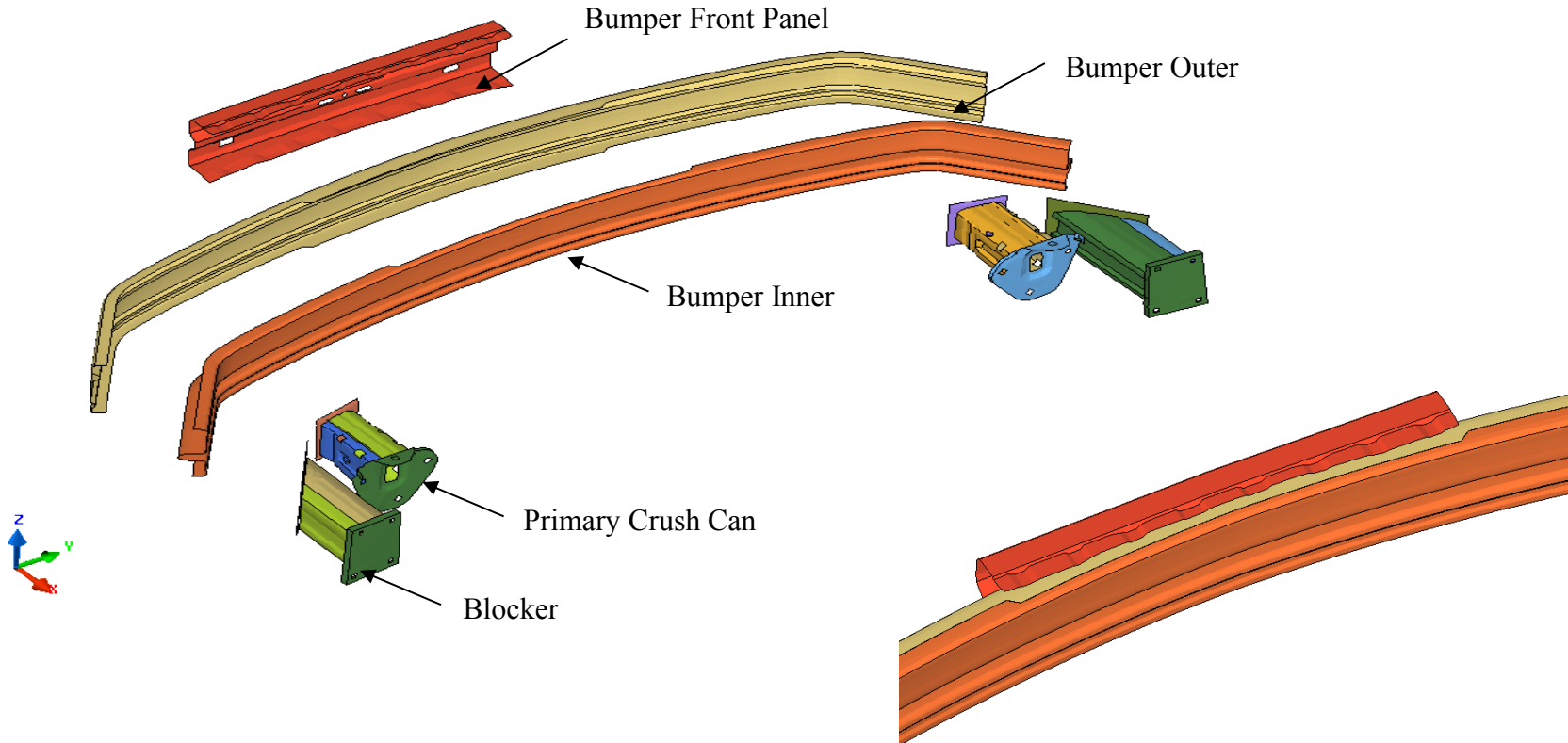

Optimized Design Summary

- ❖ DOE has been generated with High Strength Materials and Different cross section of Bumper Beam.
- ❖ Totally 76 Samples was generated to find the Optimum design.
- ❖ Response such as Intrusions, Part Mass & Buckling effect are major consideration.
- ❖ Finally we arrived the Design with nearly 9%(two piece) and 10% (one piece) Mass saving in Bumper Design space without compromising the SORB and Low speed Impact Performance.

Design Space Mass – 8.04 kg

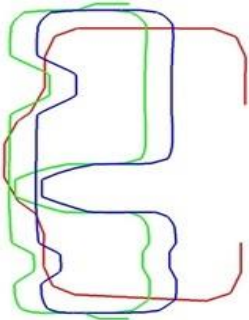

Bumper Beam C/S

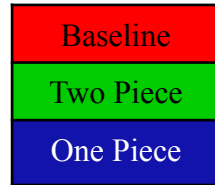

One Piece Design

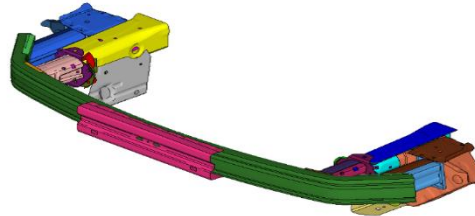

One piece design Mass – 7.23 kg

Two Piece Design

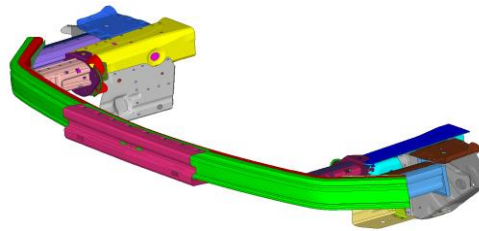



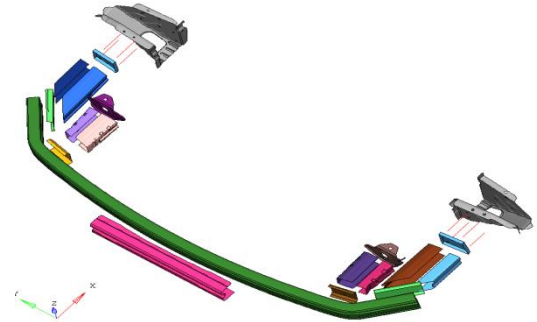

Two piece design Mass – 7.33 kg

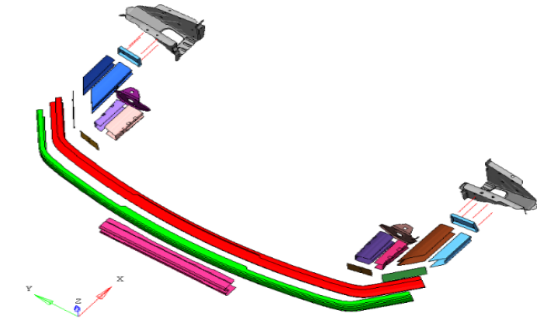



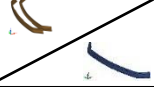

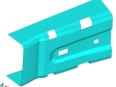
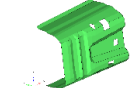
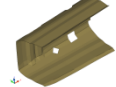
Exploded View

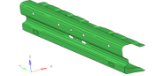
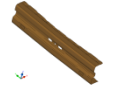

Front Bumper Assembly BOM

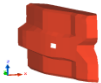
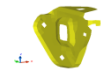
Baseline						Optimized Designs				
S.NO	Component Name	Snip	Material	Gauge (mm)	Mass (kg)	Component Name	Two Piece One Piece	Material	Gauge (mm)	Mass (kg)
1	Bumper Beam		HF 1050-1500	2.00	3.76	Bumper Beam		PHS 1900	1.0	4.26 4.16
2	Crush Can Inner		DP 500-800	1.60	0.31	Crush Can Inner		DP 500-800	1.60	0.38
3	Crush Can Outer		DP 500-800	1.60	0.46	Crush Can Outer		DP 500-800	1.60	0.54
4	Bumper Beam Reinforcement		HF 1050-1500	1.20	0.19	NA	NA	NA	NA	NA
5	Back Plate		IF 300-420	1.60	0.07	NA	NA	NA	NA	NA
6	Bumper Front Panel		DP 500-800	1.80	1.73	Bumper Front Panel		PHS 1900	1	0.90

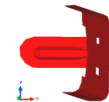
Front Bumper Assembly BOM

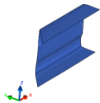
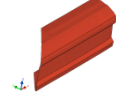
Baseline						New Design				
S.NO	Component Name	Snip	Material	Gauge (mm)	Mass (kg)	Component Name	Two Piece One Piece	Material	Gauge (mm)	Mass (kg)
7	Bumper Beam End cover		IF 300-420	1.60	0.30	NA	NA	NA	NA	NA
8	Crush Can Back Plate		IF 300-420	2.3	0.56	Crush Can Back Plate		PHS 1900	0.8	0.19
9	Bumper Beam Back Plate		IF 300-420	2.3	0.4	Bumper Beam Back Plate		PHS 1900	0.8	0.09
10	Crush Can Front Plate		IF 300-420	2.3	0.26	NA	NA	NA	NA	NA
11	NA	NA	NA	NA	NA	Secondary Crush Can Inner		TBF980	0.8	0.24
12	NA	NA	NA	NA	NA	Secondary Crush Can Outer		TBF980	0.8	0.40

Front Bumper Assembly BOM

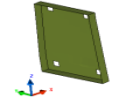
Baseline						New Design				
S.NO	Component Name	Snip	Material	Gauge (mm)	Mass (Kg)	Component Name	Two Piece One Piece	Material	Gauge (mm)	Mass (kg)
13	NA	NA	NA	NA	NA	Bumper Beam Support		PHS 1900	0.8	0.16
14	NA	NA	NA	NA	NA	Secondary Crush Can Back Plate		PHS 1900	0.8	0.17
BASELINE TOTAL MASS (Kg)				8.04		NEW DESIGNS TOTAL MASS (Kg)				7.33 7.23

- ❖ Bumper Designs were 700 (two piece) and 800 (one piece) grams lighter than the Baseline design space considered for the SORB Performance Optimization.

Bumper Design

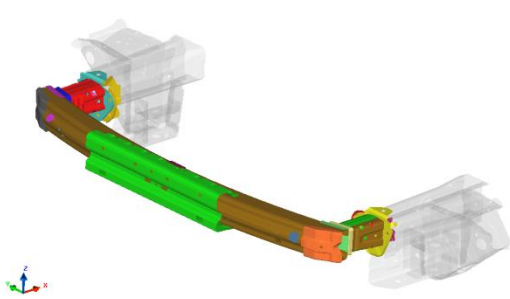

Baseline

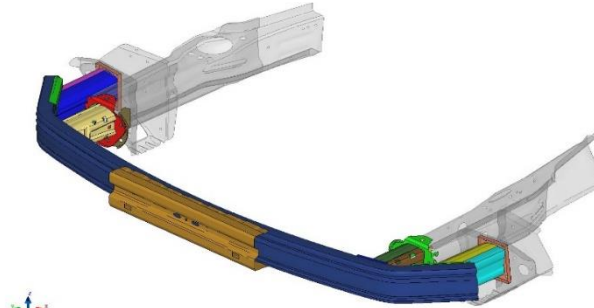

One Piece

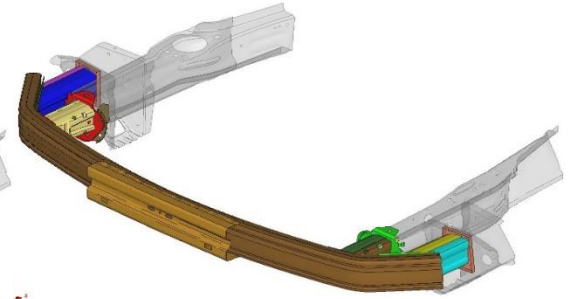

Two Piece

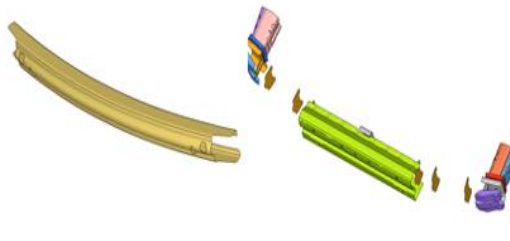

Total Components = 24

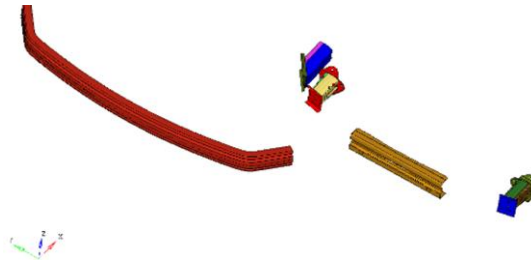

Total Components = 22

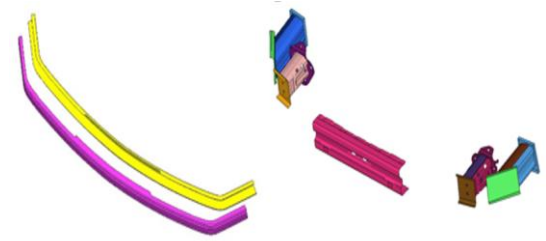

Total Components = 23

Conclusion

- ❖ Bumper Design change has improved the Vehicle overall Performance for the SORB and Low speed performance.
- ❖ Bumper Design shape using Meshworks Parameterization has achieved Optimum Design within the given Design Space.
- ❖ In addition to the Performance enhancement, the Optimization has also achieved mass saving as compared to the Design Space considered for Optimization.
- ❖ Part count have reduced in the optimized designs.

Conclusion

- ❖ Optimized Design has satisfied the Low speed impact criteria by protecting the adjacent subsystems like Hood, CRFM, Rails etc., without any damage.
- ❖ Optimized Bumper Design meets the SORB performance for both Passenger and Driver side Performance.
- ❖ The study concludes that the Bumper Design Space can provide a Design solution for meeting the SORB performance both on Driver and Passenger side.

Thank you.
Have a great day!