

GREAT DESIGNS IN
STEEL

THE ALL-NEW JEEP® WRANGLER

APRIL BAGLEY

Body Systems & Components Engineering

FCA US LLC

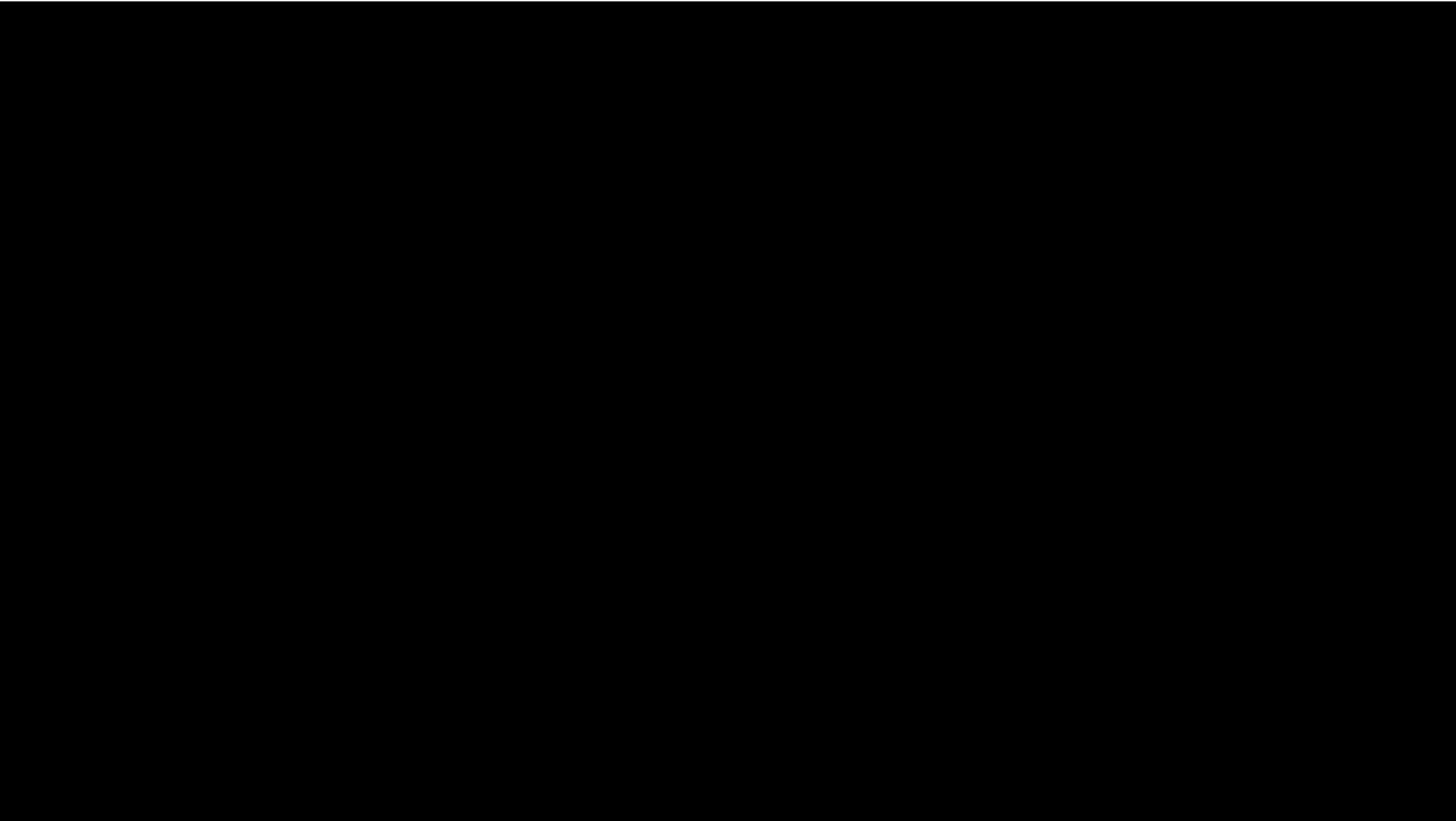

The Jeep logo is rendered in a bold, metallic, 3D-style font. The letters are silver with a dark grey shadow, giving it a sense of depth and ruggedness. A small registered trademark symbol (®) is located at the bottom right of the 'p'.

Jeep®

THE **ALL-NEW** JEEP® WRANGLER

APRIL BAGLEY

Body Systems & Components Engineering

FCA US LLC

VEHICLE INTRODUCTION

- Design & Architecture Concept
- Customer-driven functionality
- Engineering challenges

BODY TECHNOLOGY

- Structure concept
- Body design highlights
- Materials strategy & weight





VEHICLE OVERVIEW

HERITAGE & DESIGN

Jeep® Wrangler Heritage

Jeep®

EVOLUTION OF AN ICON

Over the years the face of the Wrangler has evolved and been refined. It was originally an engineering solution for the harsh demands of war but after that time it became a civilian vehicle and was met with much success. The unique face has held its own over time and continues to be a trademark of the Jeep brand.



MODEL
1941 MB



MODEL
1945 CJ2



MODEL
1954 CJ5



MODEL
1987 YJ



MODEL
1997 TJ



MODEL
2007 JK

Worldwide Markets – Global Validation

Jeep®



- 3.7 million sold since 1987 (YJ)
- Sold in >110 countries
- >6.3 million Km of worldwide validation testing in 5 countries

Concept Sketches

Jeep®

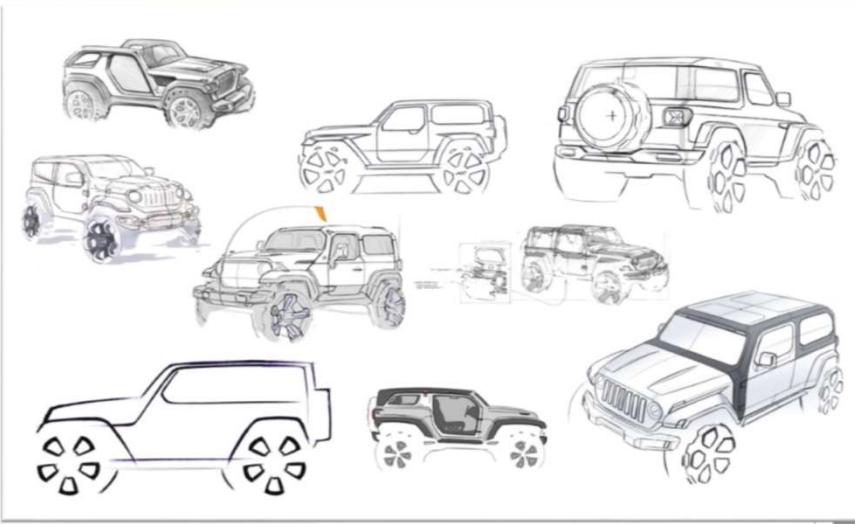

Final Theme

Jeep®

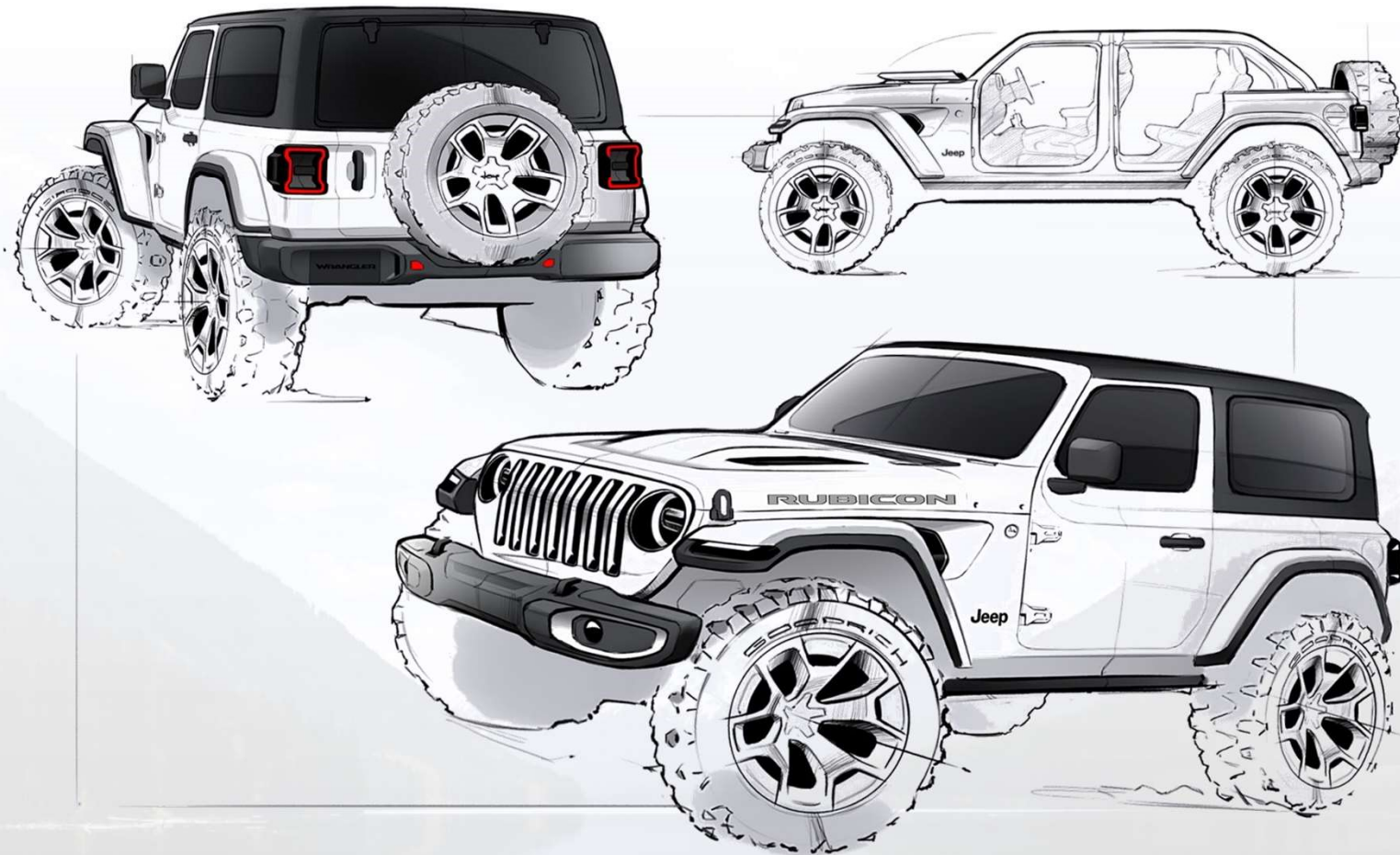

Interior Comfort

Jeep®





UNIQUE
VEHICLE CAPABILITY

ENGINEERING
CHALLENGES

Body Engineering Challenges



Performance Improvements

- Improved NVH – Body Stiffness, Acoustics
 - New Safety standards
- Hot Blow-Formed Sports Bar*

Fuel Economy Improvements

- New powertrains
- Electrification package
- Improved aerodynamics

Removable Body Systems

- Fold-down Windshield frame
 - Removable Roof/Closures
- 3 Roof Systems*



Chassis & Vehicle Objectives

- Lightweight Frame package
- Increased wheelbase, length and track
- Efficient material strategy

Body Engineering Challenges

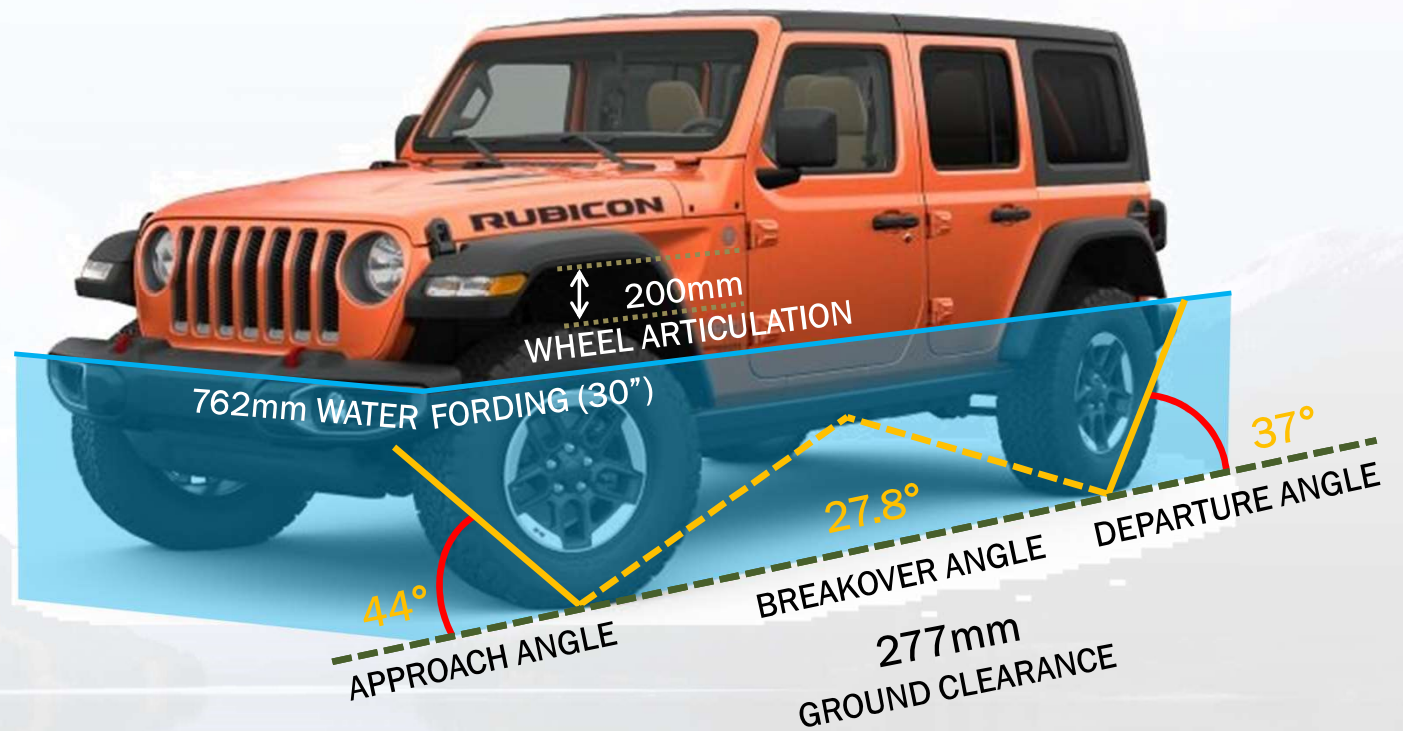
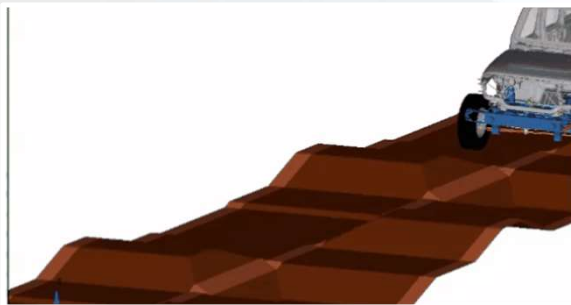

Fuel-Efficient Powertrains



2.2L TURBO DIESEL ESS

3.0L TURBO DIESEL ESS

2.0L PETROL ESS

3.6L PETROL ESS

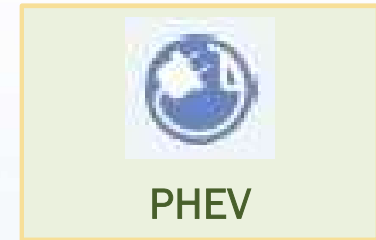

147 kW
450 Nm Torque

Coming 2019

201 kW
400 Nm Torque

212 kW
353 Nm Torque



850RE
8-Speed Automatic Trans
w/ Full Time T-case



D478
6-Speed Manual Trans w/
Full Time T-case

* SAE Power numbers

Dimensional Comparison (4-Door)



- New JL Wrangler
- JK Wrangler

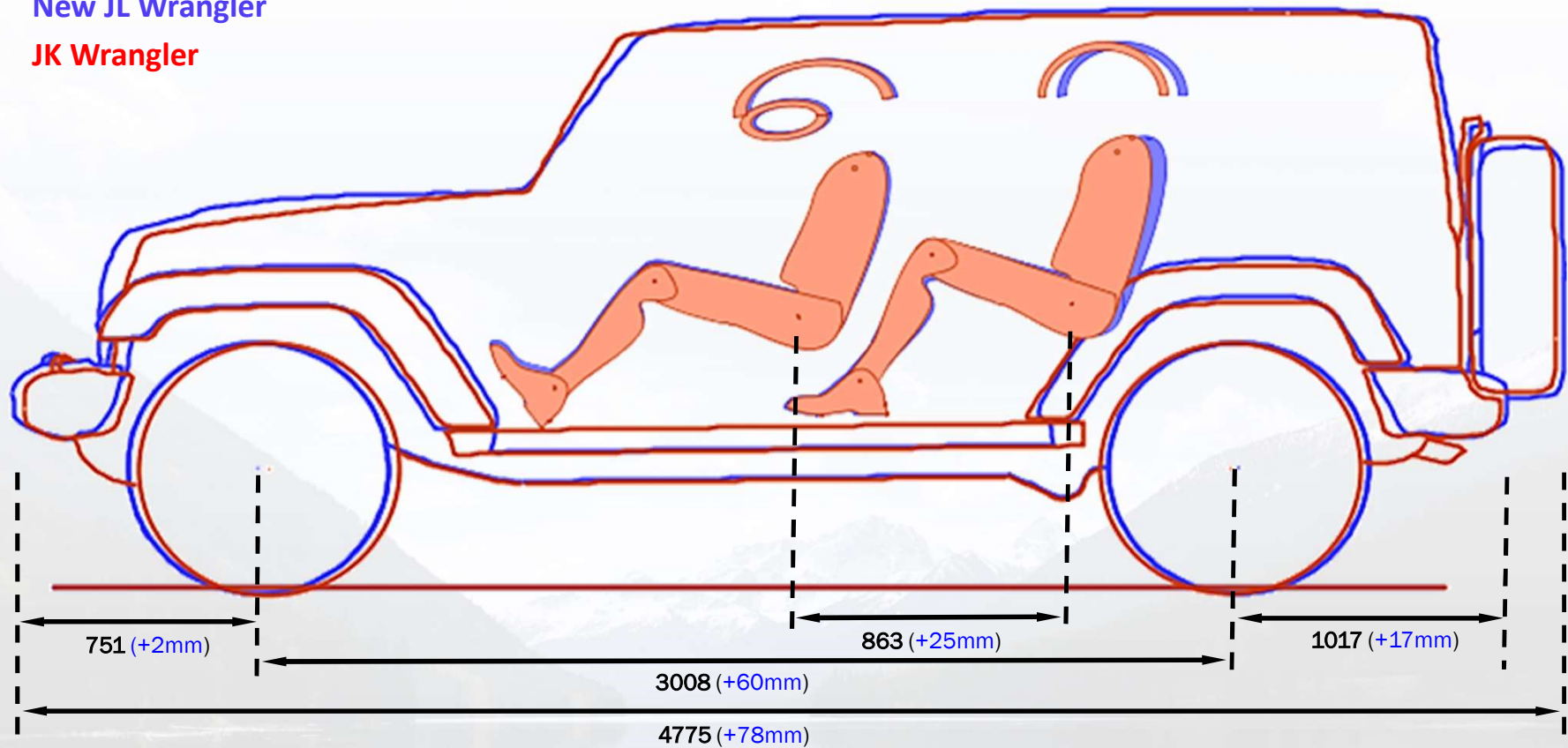

Aerodynamics Improvements



9.4% C_D reduction

Rear Aero Lip

A-Pillar Profile

Windshield Angle

D-Pillar Profile

Fascia Closeout
& Grille Seals

Mirror Surfaces

Tapered Fender Flare

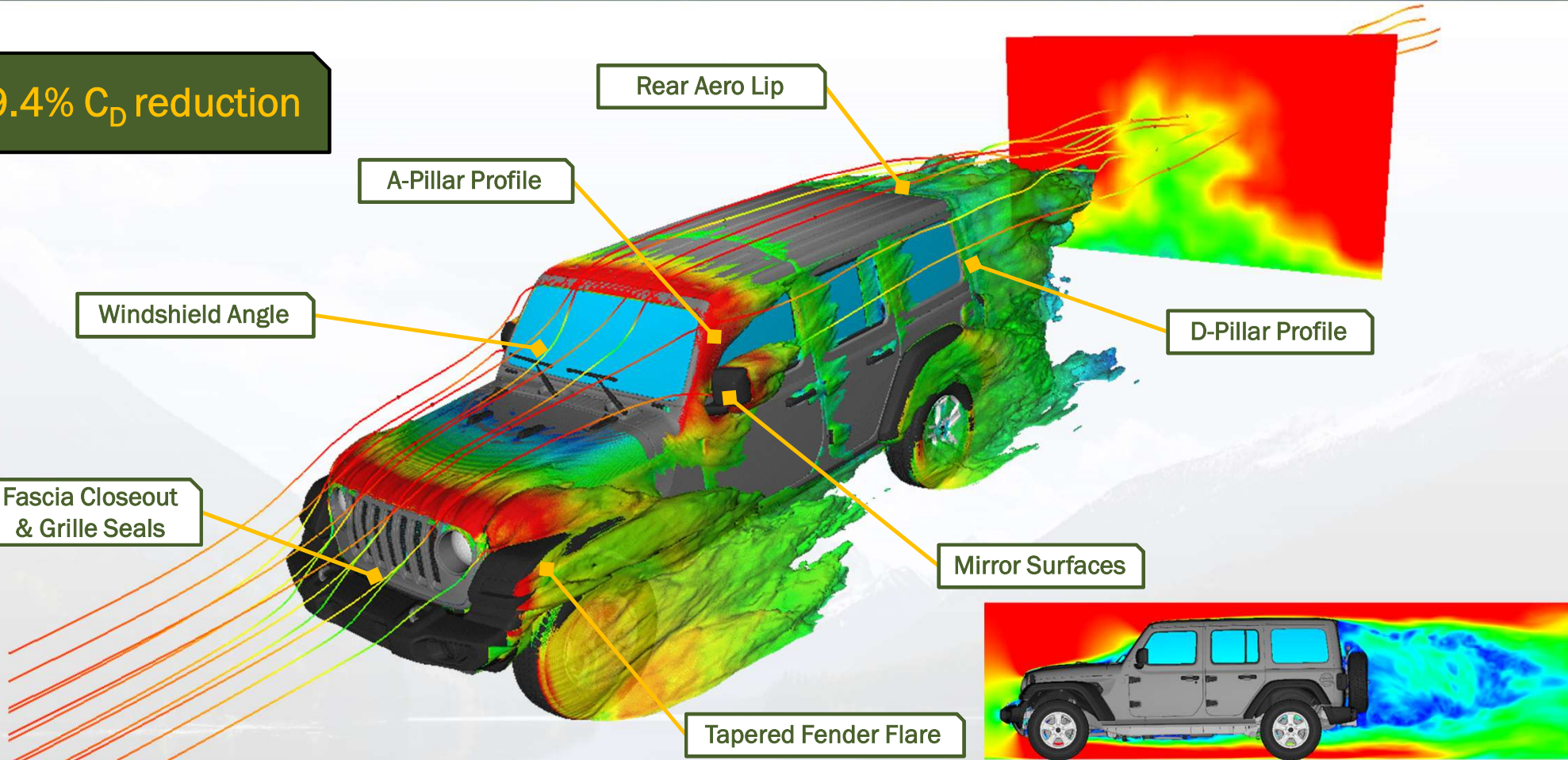

New Safety Features



MORE THAN

70

SAFETY +
SECURITY
SYSTEMS

ACTIVE TURN SIGNALS | ADJUSTABLE HEAD RESTRAINTS | ADVANCED MULTISTAGE AIR BAGS | ALL-SPEED TRACTION CONTROL SYSTEM | ANTILOCK BRAKE SYSTEM (ABS) | ANTI-LOCK BRAKE SYSTEM WITH ROUGH-ROAD DETECTION | AUTO-DIMMING REARVIEW MIRROR | AUTOMATIC HEADLAMPS | BELT ALERT | BLIND-SPOT MONITORING (BSM) | BRAKE-LOCK DIFFERENTIAL SYSTEM (BLDS) | BRAKETHROTTLE OVERRIDE | BRAKE/PARK INTERLOCK | CENTER HIGH-MOUNTED STOP LAMP | CHILD-PROTECTION REAR DOOR LOCKS | CHILD SEAT ANCHOR SYSTEM | CONSTANTFORCE RETRACTORS (CFR) | DAYTIME RUNNING LAMPS (DRL) | DRIVER INFORMATION DISPLAY (DID) INSTRUMENT CLUSTER DISPLAY | DUAL-NOTE ELECTRIC HORNS | ENHANCED ACCIDENT RESPONSE SYSTEM (EARS) | ELECTRONIC BRAKE-FORCE DISTRIBUTION | ELECTRONIC ROLL MITIGATION (ERM) | ELECTRONIC STABILITY CONTROL (ESC) | ENERGY-ABSORBING STEERING COLUMN | ENERGY MANAGEMENT SYSTEM | EXPRESS DOWN WINDOWS | FOG LAMPS | FRONT SEAT-BELT ADAPTIVE LOAD LIMITERS | FRONT SEAT-BELT PRETENSIONERS | FRONT AND REAR CRUMPLE ZONES | FRONT-SEAT MOUNTED SIDE PELVIC THORAX BAGS | FULL-SIZE SPARE TIRE | GLOBAL POSITION SENSOR (GPS) | HEADLAMP TURN-OFF TIME DELAY | HEATED SIDEVIEW MIRRORS | HEIGHT-ADJUSTABLE SEAT BELTS (FRONT-ROW) | HILLSTART ASSIST (HSA) | HILL-DESCENT CONTROL | HYDRAULIC BOOST COMPENSATION | INTELLIGENT BATTERY SENSOR (IBS) | KEYLESS ENTER 'N GO® | LED HEADLAMPS | LED TAIL LAMPS | MOPAR® ELECTRONIC VEHICLE TRACKING SYSTEM (EVTS) | OCCUPANT RESTRAINT CONTROLLER | PARKSENSE® REAR PARK ASSIST SYSTEM | PARKVIEW® REAR BACKUP CAMERA | RAIN BRAKE SUPPORT | READY ALERT BRAKING (RAB) | REAR CROSS PATH (RCP) DETECTION | REAR-WINDOW ELECTRIC DEFROST | REAR WIPER | REMOTE KEYLESS ENTRY | REMOTE START | ROADSIDE ASSISTANCE AND SOS CALL | SAFETY CAGE BODY STRUCTURE | SEATBELT LATCH DYNAMIC LOCKING TONGUE | SECURITY ALARM | SENTRY KEY ENGINE IMMOBILIZER | SIDE GUARD DOOR BEAMS | SIRI EYES FREE | SPEED-SENSITIVE DOOR LOCKS | STEERING WHEEL-MOUNTED AUDIO CONTROLS | THREE-POINT SEAT BELTS | TILT-AND-TELESCOPING STEERING COLUMN | TIRE-PRESSURE MONITORING (TPM) SYSTEM | TRAILERSWAY CONTROL (TSC) | UCONNECT® ACCESS REMOTE SERVICES | UCONNECT® ACCESS STOLEN VEHICLE LOCATION ASSISTANCE | UCONNECT® DRAG AND DROP MENU BAR | UCONNECT® VOICE COMMAND | UNIVERSAL GARAGE DOOR OPENER | AUTO TUNNEL DETECTION | AUTO HEADLAMP LEVELING | SIDE MARKERS SIDE VIEW MIRRORS |



OPEN AIR



Tops System Configurations

Jeep®



2-Door Roof Options

- Hard Top
- Soft Top

4-Door Roof Options

- Hard Top
- Soft Top
- *Power Top*



Jeep® Gladiator

Jeep®



- Exceptional off-road capability
- Maintains open air environment
 - Hard top/soft top/folding windshields/removable doors



BODY TECHNOLOGY

STRUCTURAL CONCEPT

Body System Development Objectives



Customer Experience

- Exceptional off-road capability
- Driving Refinement
 - Comfort, Ride, Noise & Vibration
- Safety performance



Reduced Weight

- Enable 1 TWC class reduction, improved fuel economy
- Efficient application of new materials
- Strategic application of lightweight materials with direct customer benefit



Structural Loadpath Concept

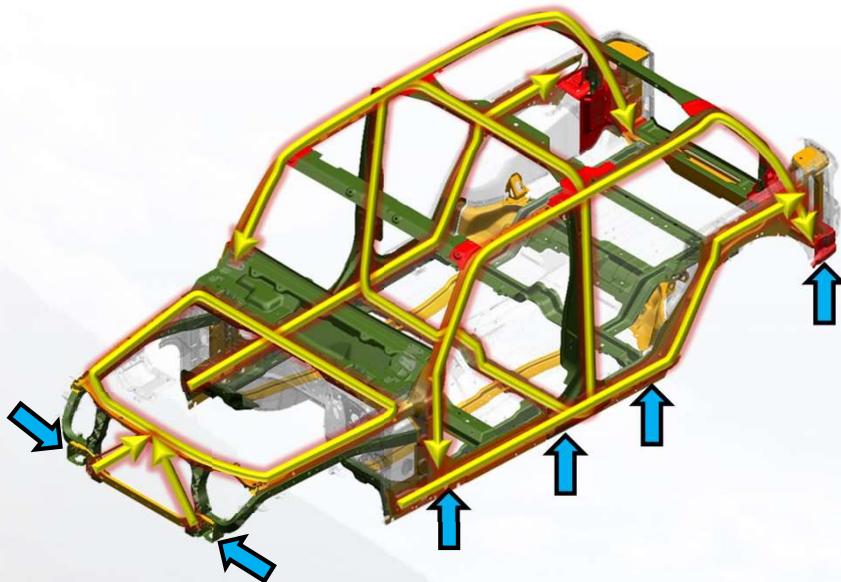

- Improved ride comfort by enhanced distribution of vibration energy inputs
 - Evolved loadpath concept with improved design of key structural joints
 - Balanced body stiffness with frame stiffness
 - Tactile responses are less sensitive to vibration input

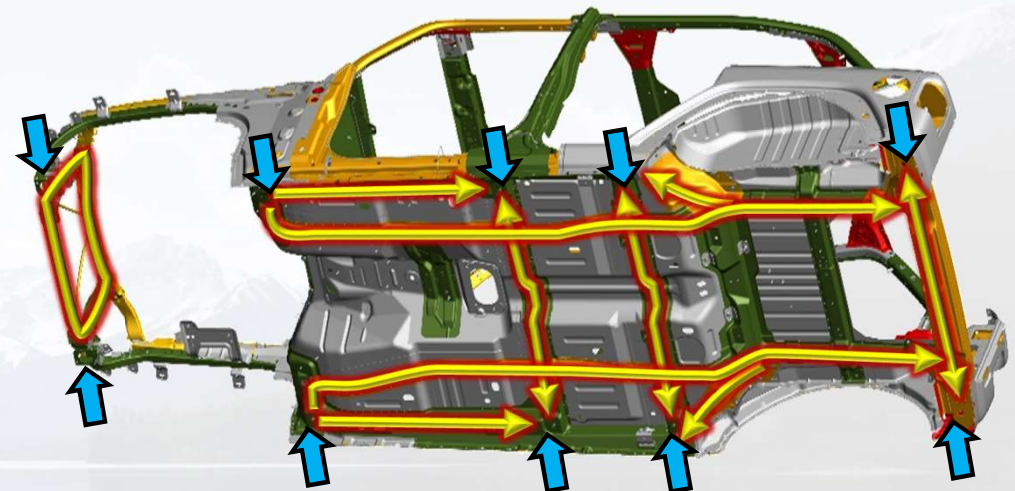

- Primary Loadpath
- New/Enhanced Loadpath
- Optimized Joint Design

Body Concept - Low Vibration Response

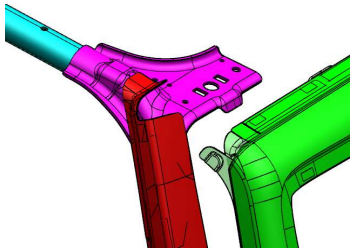

JK Wrangler

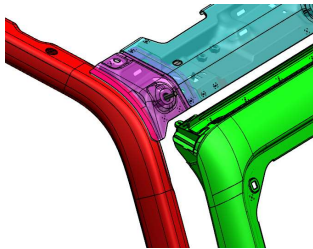

New JL Wrangler

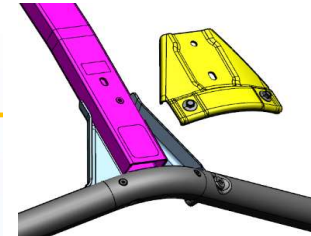
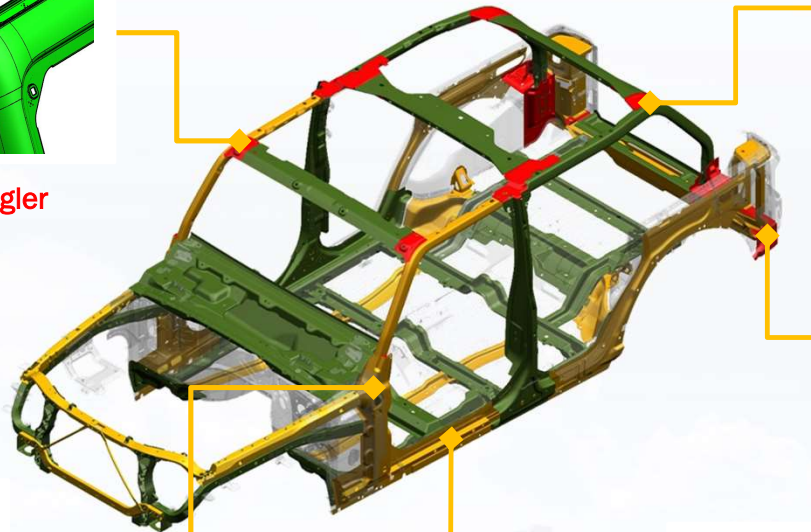

JK Wrangler

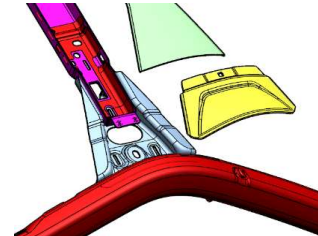

New JL Wrangler

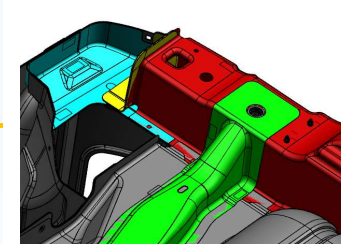

JK Wrangler

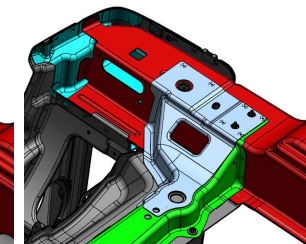

New JL Wrangler

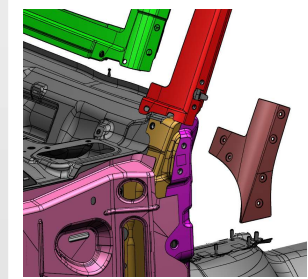

JK Wrangler

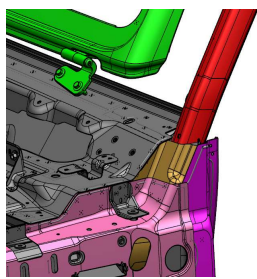

New JL Wrangler

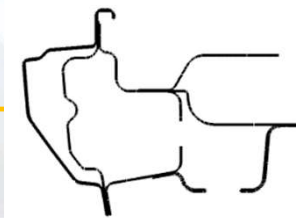

JK Wrangler

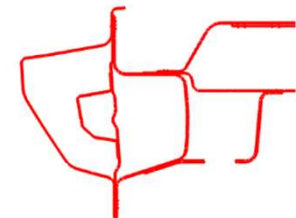

New JL Wrangler

Body Concept - Low Vibration Response

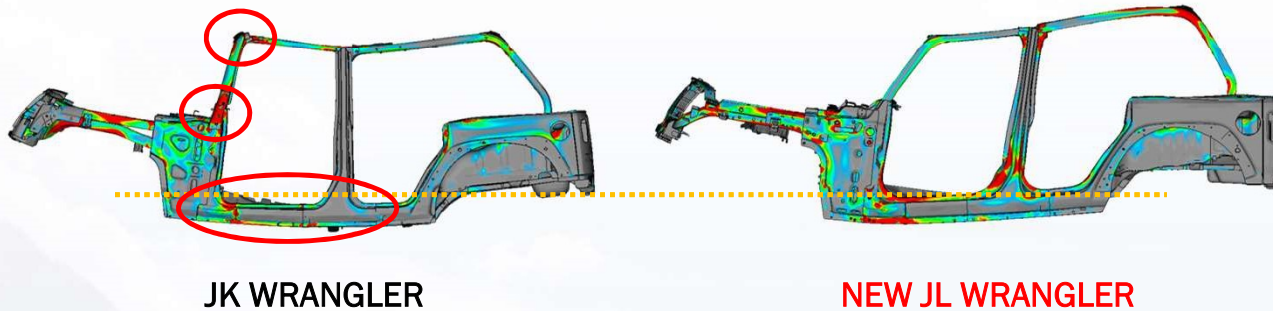

JK WRANGLER

NEW JL WRANGLER

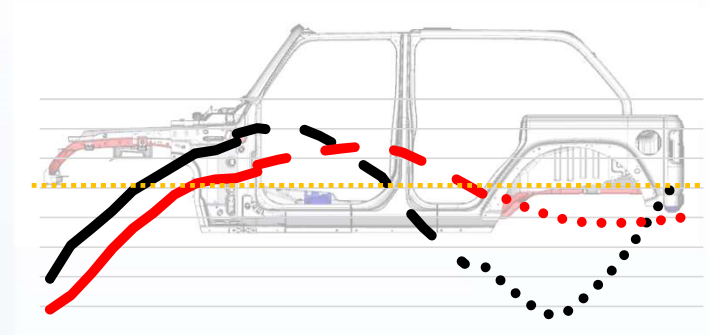

Structural Improvements

- Improved Hinge Pillar – A-Pillar loadpath continuity
- Stiffer Sill section
- Rear Rail to Sill connection

Customer Benefits

- Improved passenger comfort by lowering the excitation of the body structure to vibration inputs

4-Post Shake - Driver Seat Track Response

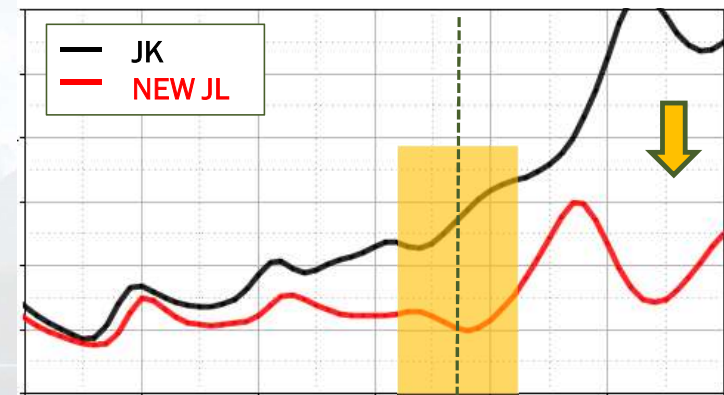

Body Weight Reduction Summary

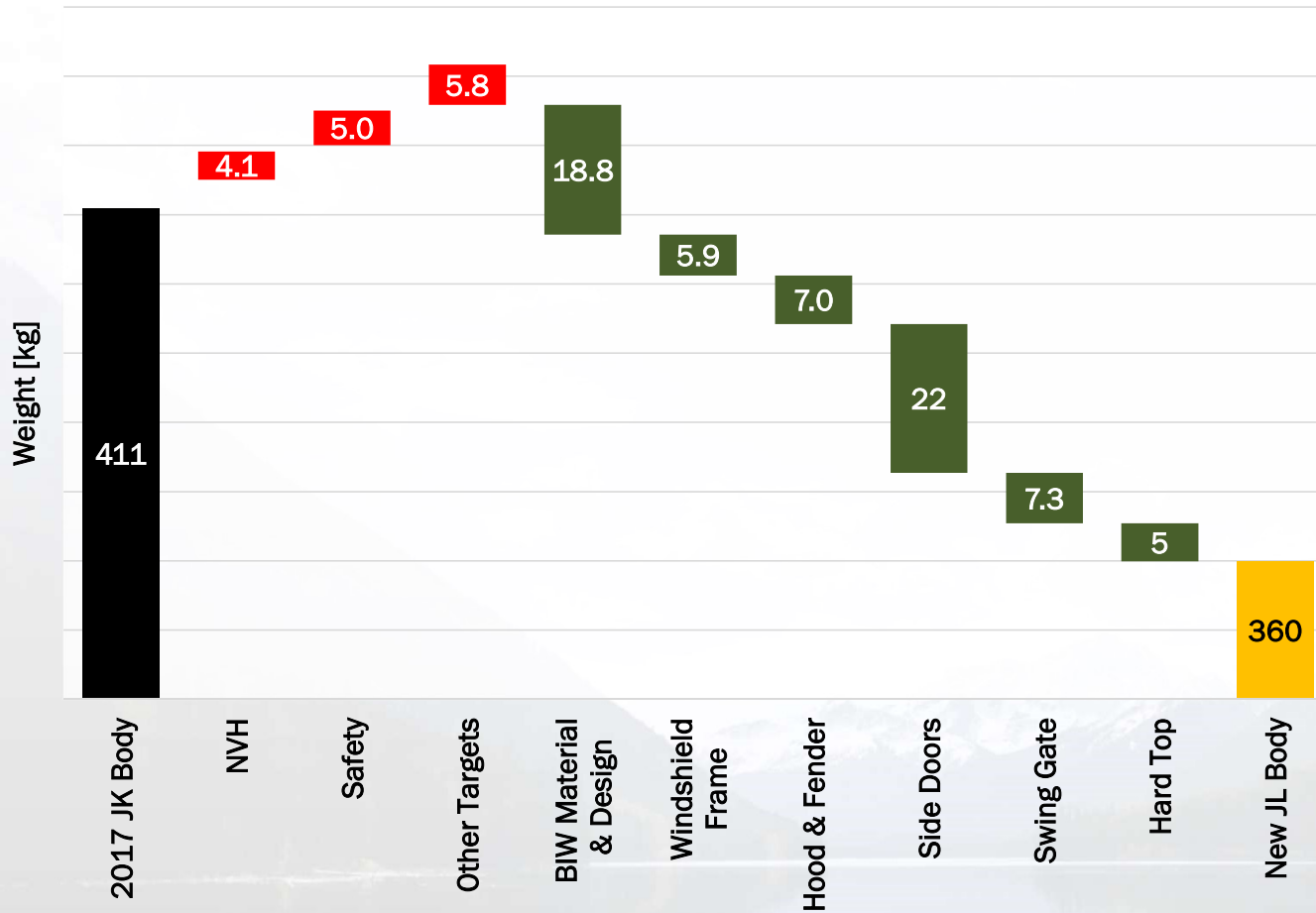

- +14.9kg required for additional functional objectives
- 24.7kg saved by BIW material and design optimization
- 36.3kg saved by lightweight closures
- 5kg saved by Hard Top material and design optimization

66kg of lightweighting achieved

51kg Lighter than Predecessor

Body Material Strategy

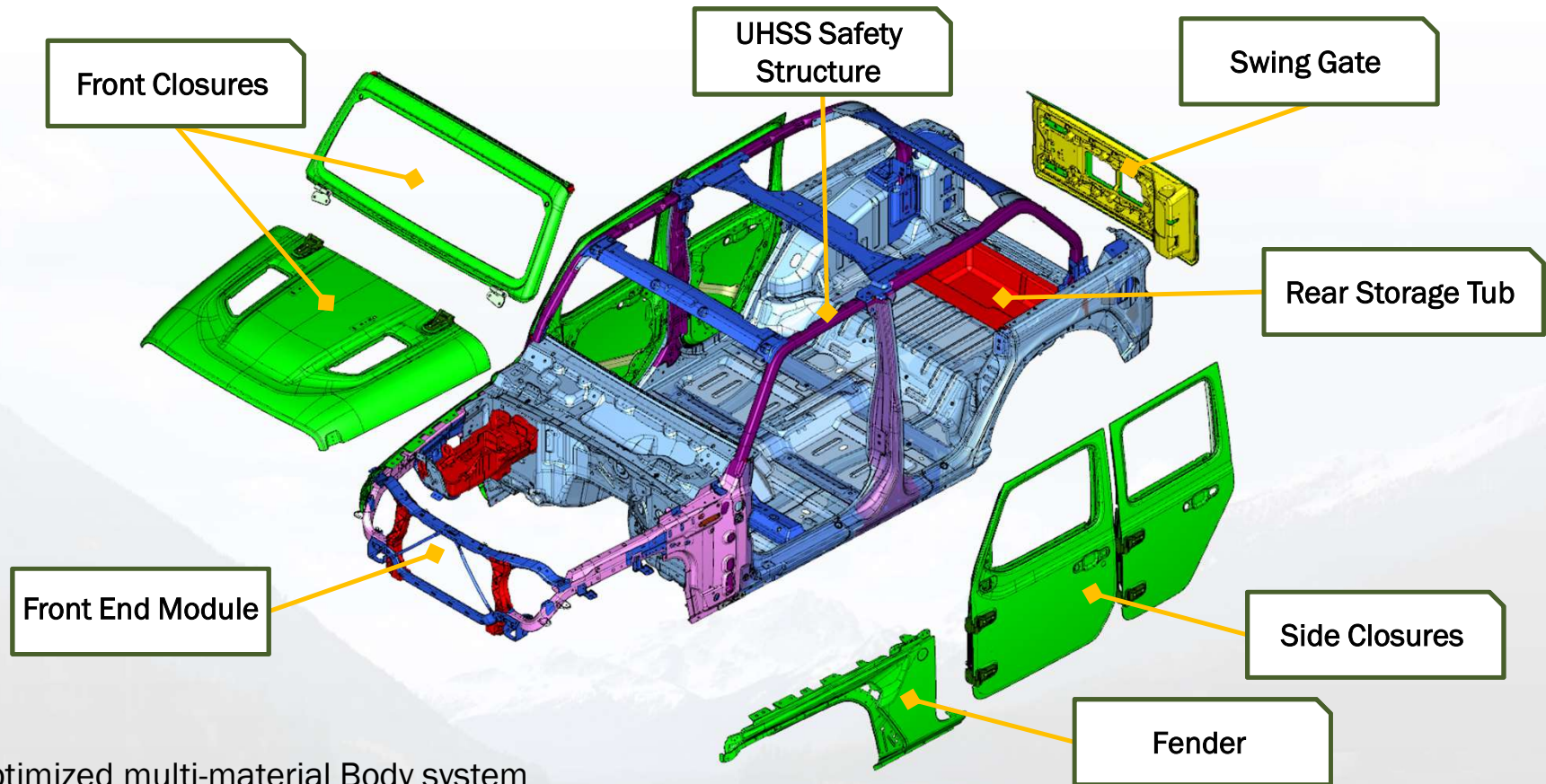

- Optimized multi-material Body system
- Applies the right material in the right place to *maximize customer value*

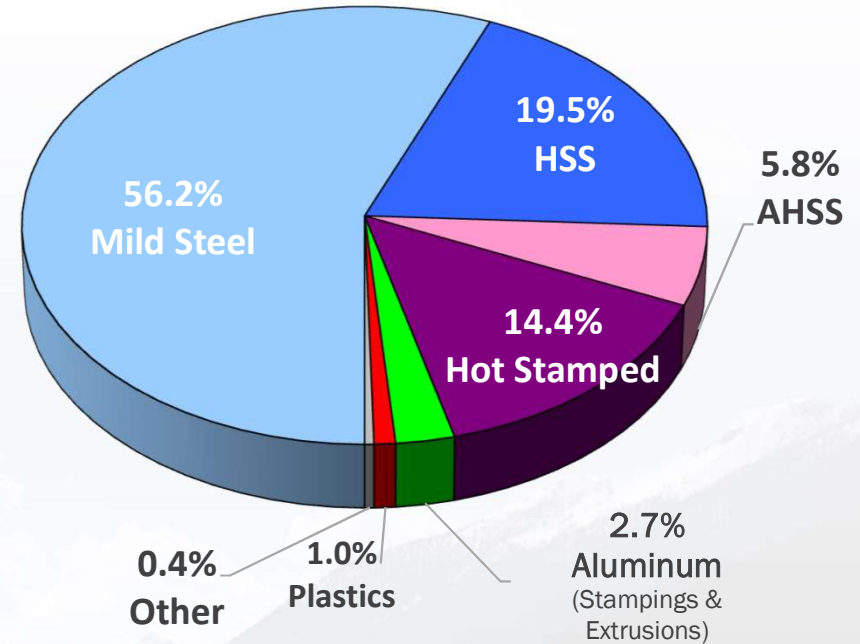
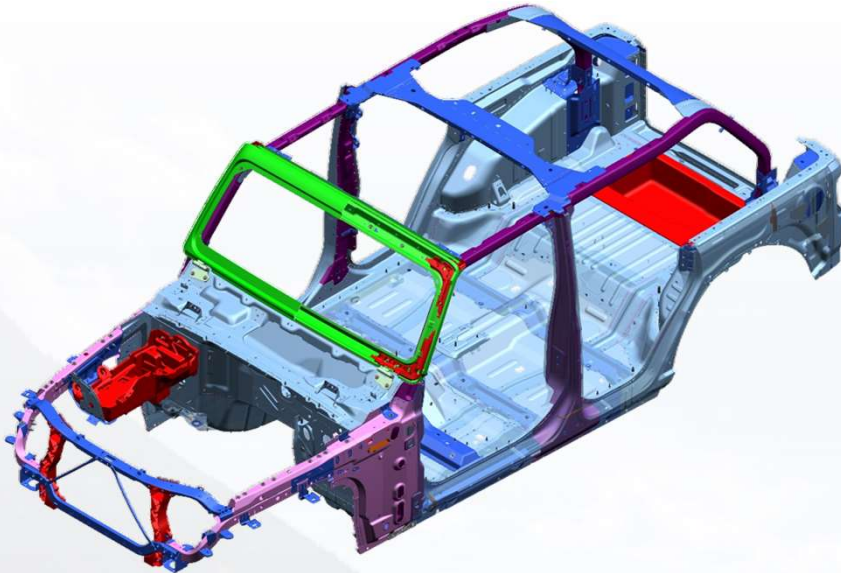

Steel-Intensive Body Structure

- Mild Steel stiffness-driven panels, closeouts and loadpaths
- AHSS and UHSS for improved impact performance
- Structural inserts at select joints to improve stiffness and strength
- Strategic Aluminum and GFRP panels for additional weight reduction

10.4kg Weight Save

Lightweight Frame



High Strength, Lightweight Frame

- High Strength Steel-intensive design (79%) with roll-formed and stamped parts
- Extruded 6061-T6 Aluminum Crossmember
- 9 Tailor-Rolled Blank (TRB) parts save 8.6kg
 - Common Front Crush tip dies with different rolling profiles for each frame variant
 - Optimized TRB thickness distribution on Rear Rail eliminates additional reinforcements, reducing assembly complexity

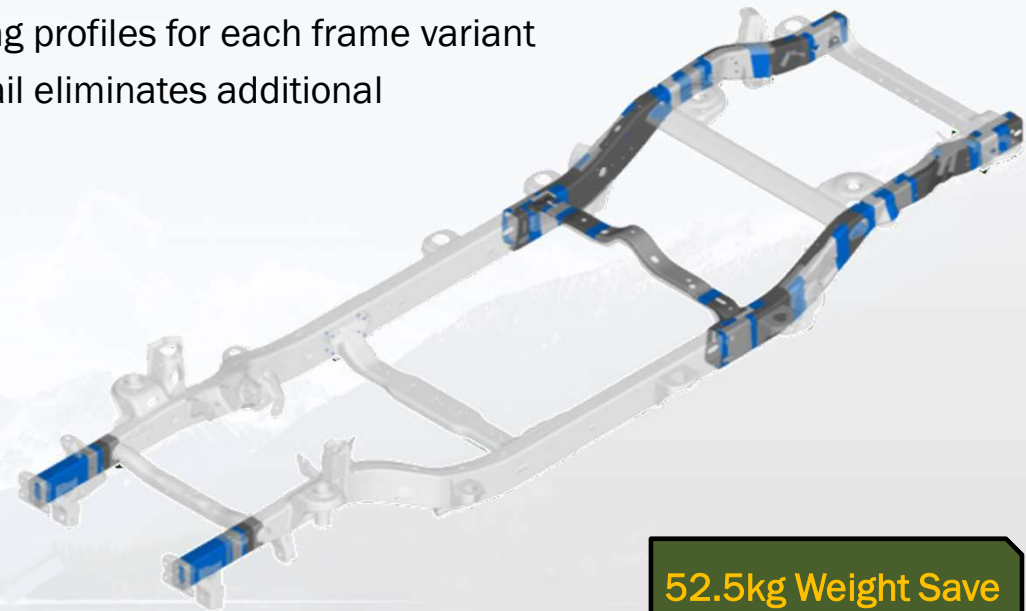
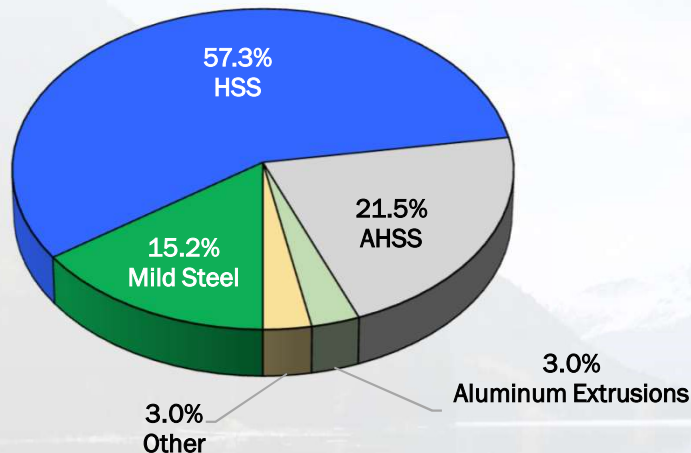

52.5kg Weight Save



-  Offensive Structure
-  Defensive Structure

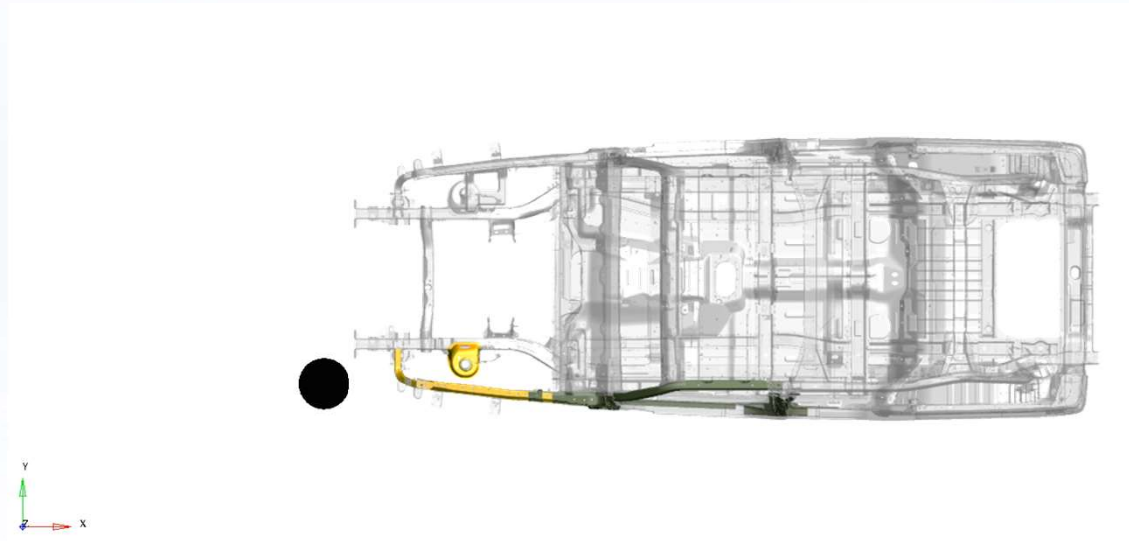

Offensive & Defensive Structures

- Structure and Solid Axle work together to enable vehicle to slide off barrier
- High strength body side structure reduces occupant compartment intrusions

SORB Strategy – Offensive Enablers

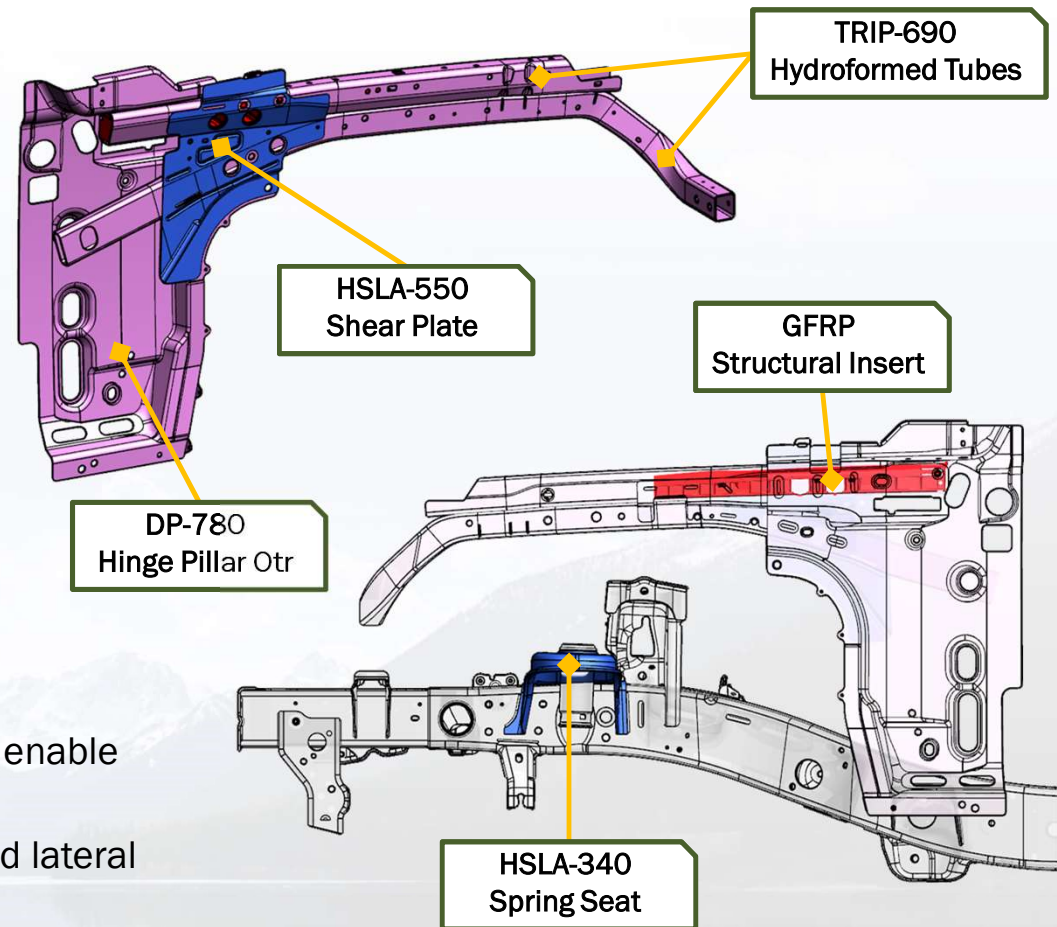
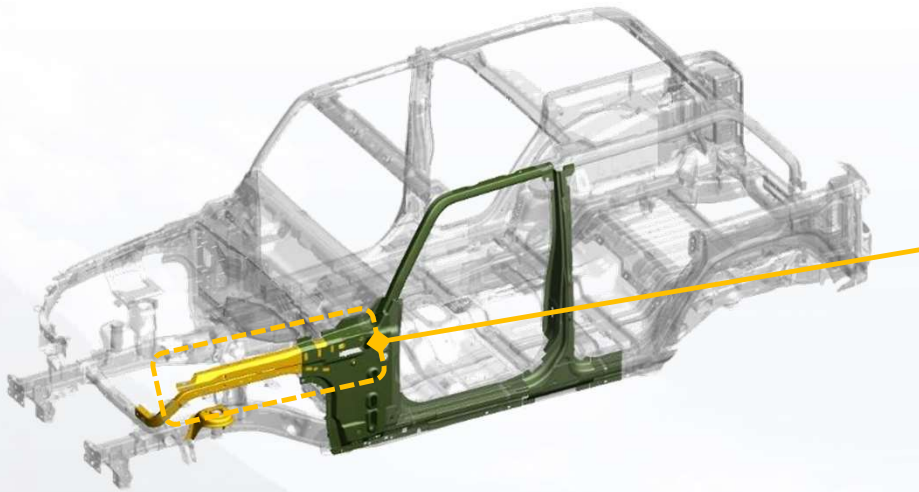

Frame & Body Structure Synergies

- Combination of Body and Frame structural loadpaths enable the lightest, most effective structural concept
- UHSS and HSS steels maximize energy absorption and lateral push off the barrier

SORB Strategy – Defensive Enablers

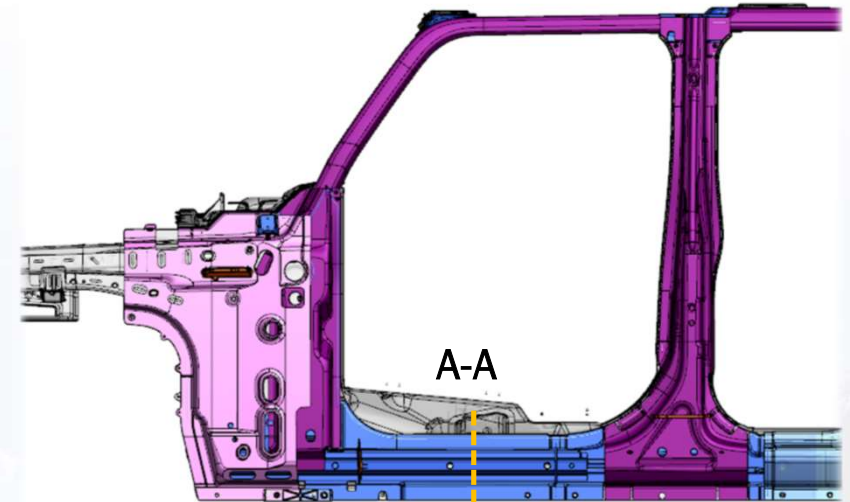

Advanced UHSS Applications

- Hot Stamped Reinforcements and High Strength Steel loadpaths provide a strong safety structure to resist intrusions
- Upgraded Sill section for higher strength
- State-of-the-art detailed simulation models used for spot weld and material rupture characterization

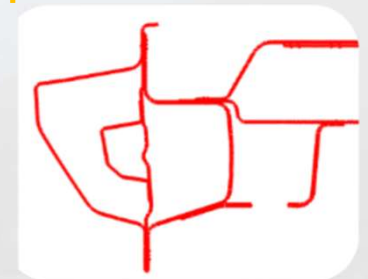

A-A

Side Impact Structure

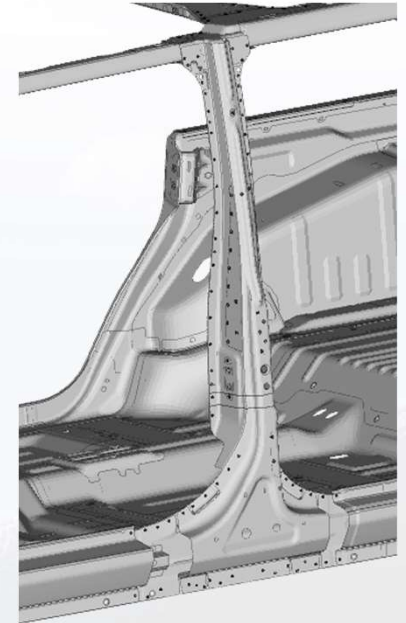
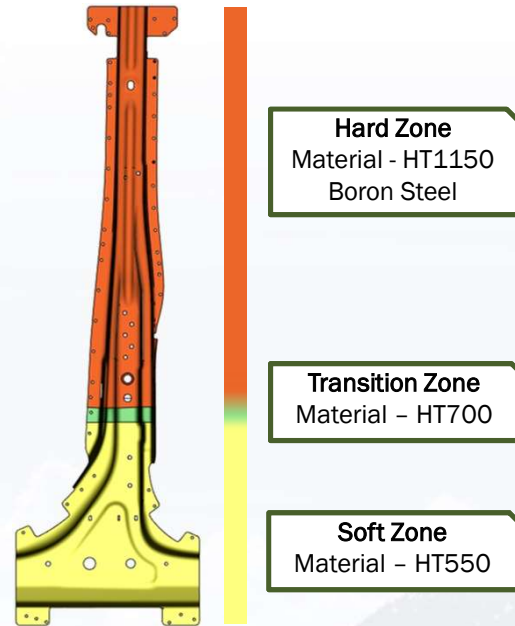
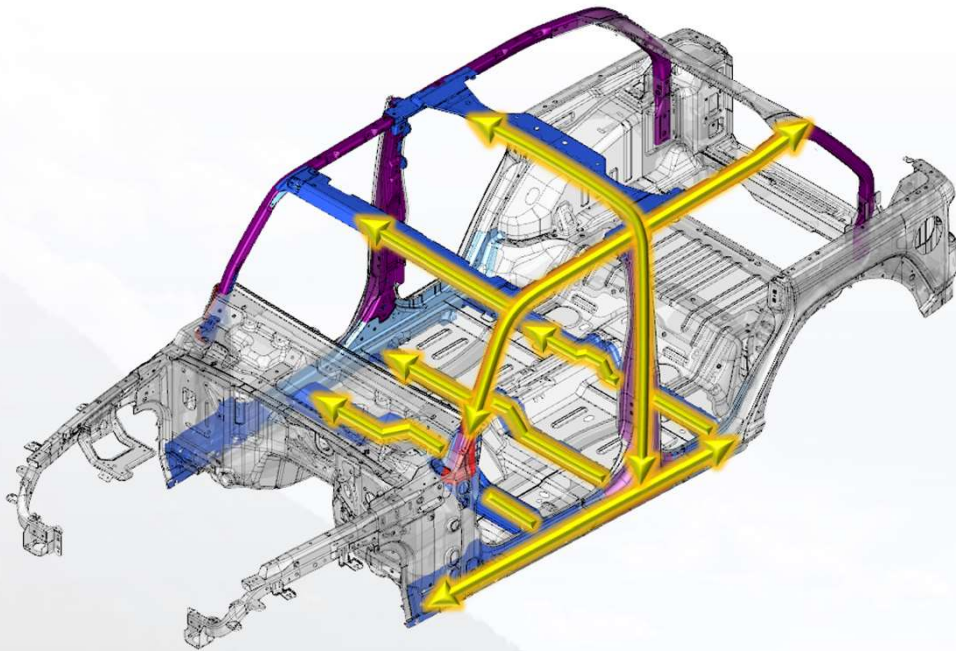

Advanced UHSS Applications

- High Strength Steel underbody cross-members
- Hot Blow-Formed Sport Bar and Hot Stamped B-Pillar with tuned soft-zones

B-Pillar with Soft Zone Technology

- Localized, in-die temperature control through the quench process prevents martensite growth
- Elongation can be increased locally to help control B-Pillar deformation and manage side impact energy

Roof Strength Loadpaths

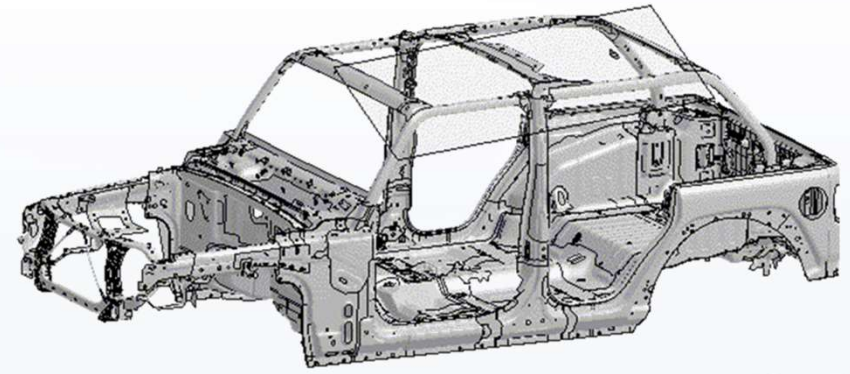
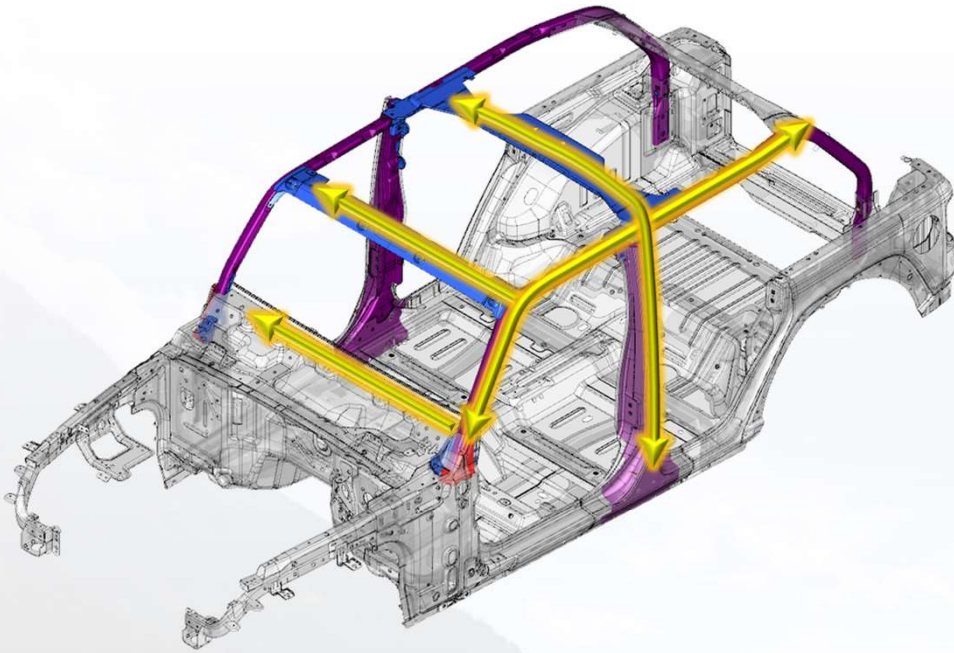

UHSS Upperbody Structure

- Hot Blow-Formed Sport Bars resist intrusion and distribute loads
- High Strength Steel Front Header/Roof Bows transfer load cross-car
- Hot Stamped B-Pillar structure resists intrusion



Hot Blow-Formed Sport Bar

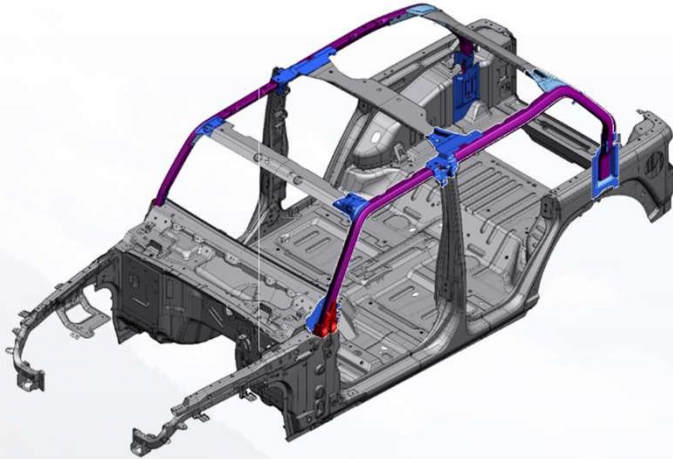

Key Benefits

1. Ultra High Strength with Variable Section Profile

- Accra is a proprietary technology capable of producing complex sections with ultra high strength martensitic structures with variable profiles
- Direct quench process provides consistent part properties

2. Improved Dimensional Capability

- Lower residual stresses enable tighter part tolerances
- Eliminates 6 bolted joints (36 bolts) per vehicle

3. Improved Styling

- Hot forming process provides a wrinkle-free surface
- Precise control of weld parameters reduces MIG-weld spatter



JK WRANGLER



NEW JL WRANGLER



MIG WELDS



5.0kg Weight Save

Multimatic produces Accra in North America under license from Linde+Wiemann

Hot Blow-Formed Sport Bar Process

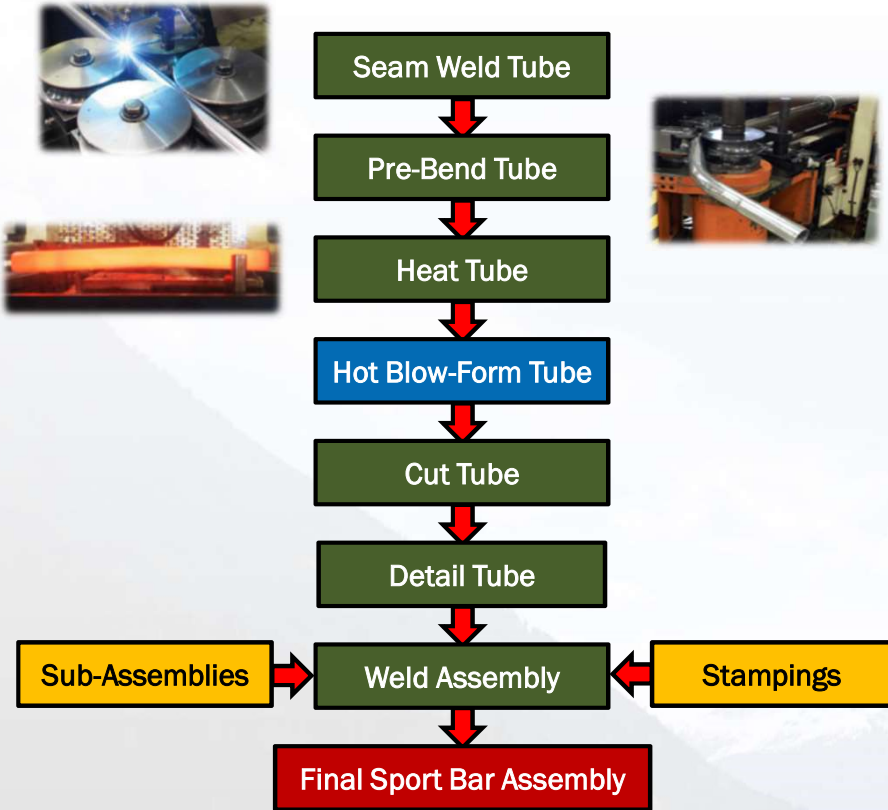

Multimatic produces Accra in North America under license from Linde+Wiemann

Body Variants (Launch)



- 2 Body configurations
- 4 BIW Variants for all global markets
- 3 Hoods
- 24 unique Body styles

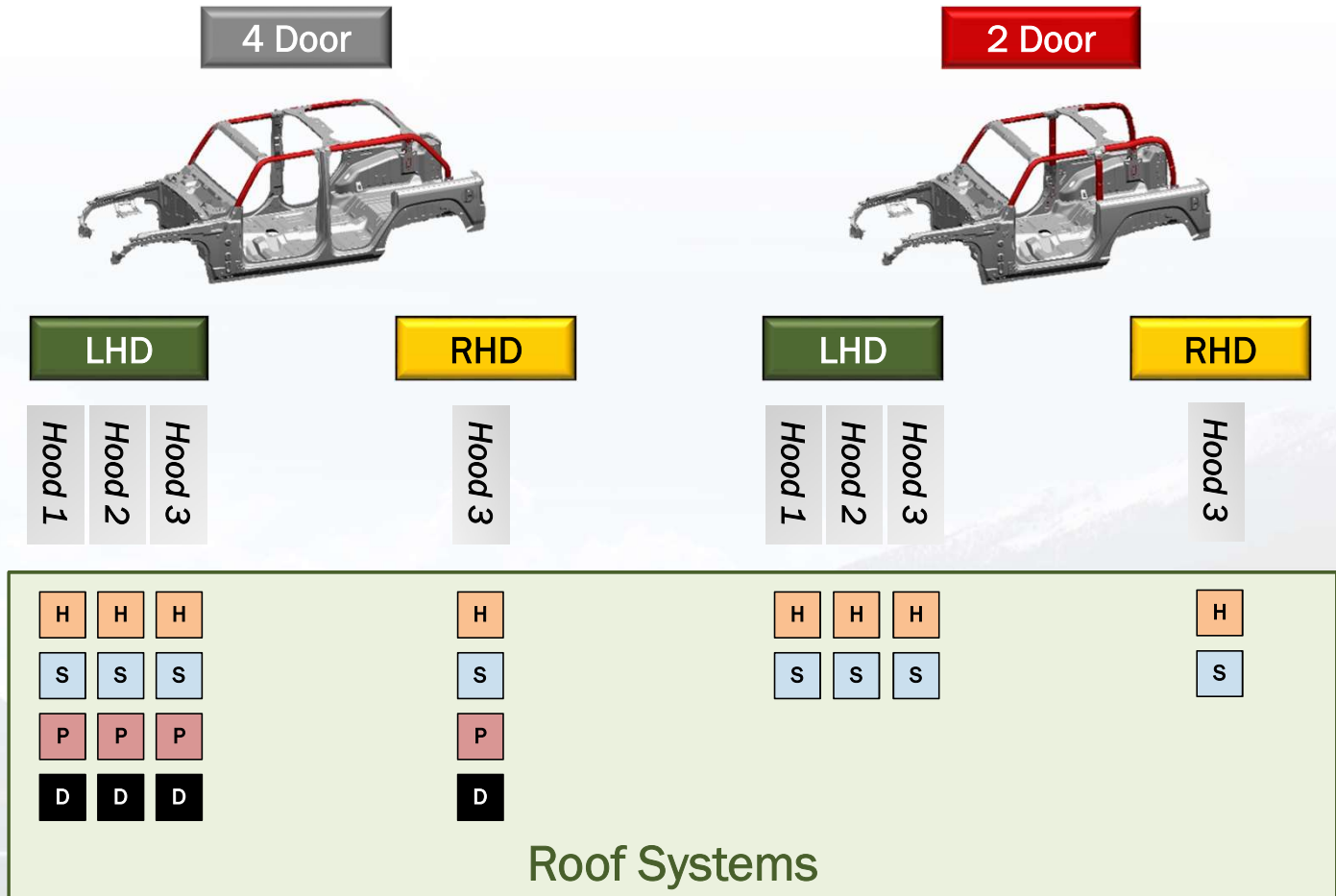

BIW Sharing Strategy (2-Door/4-Door)



- High level of up-front engineering to maximize re-use across the portfolio
- Future platform variants considered early in development
- Enabled 80% carry-over parts for 2-door variant

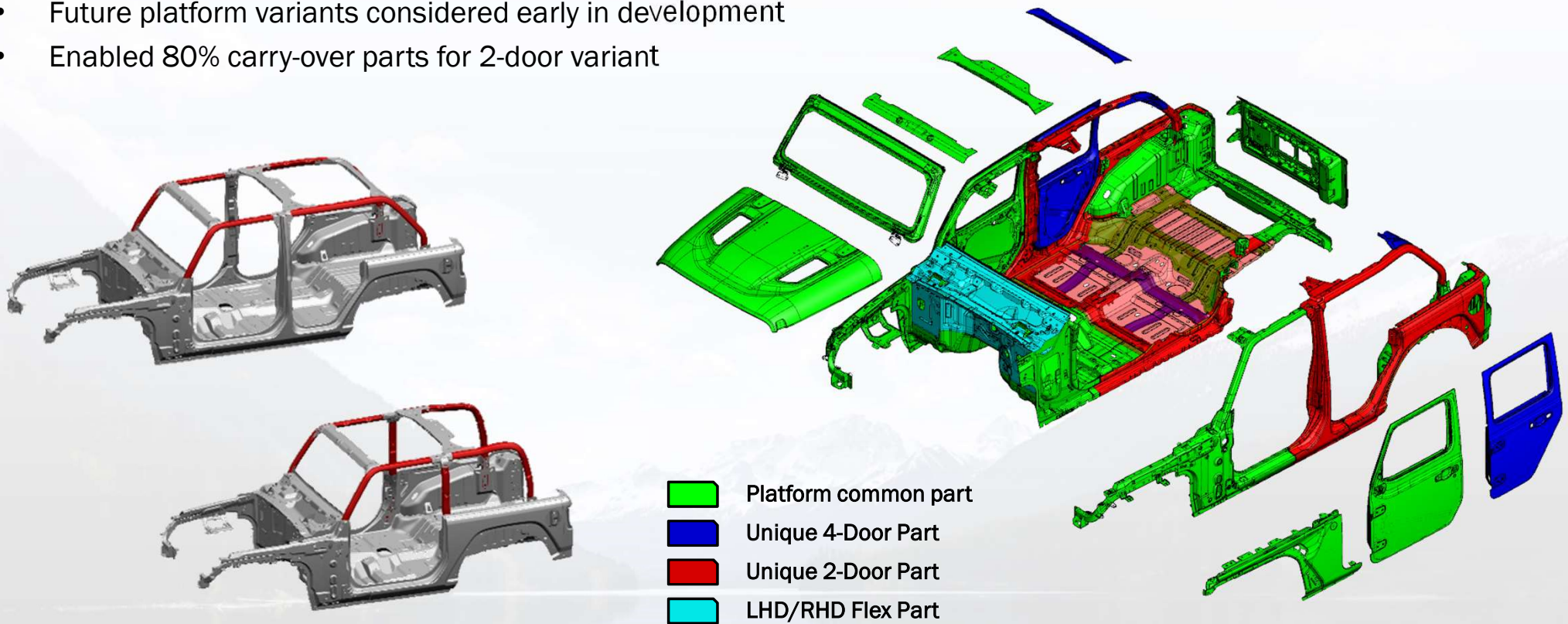



JEEP® WRANGLER

SUMMARY

Re-Cap - Body Development Objectives



Customer Experience

- Exceptional off-road capability ✓
- Driving Refinement ✓
 - Comfort, Ride, Noise & Vibration ✓
- Safety performance ✓



Reduced Weight

- Enable 1 TWC class reduction, improved fuel economy ✓
- Efficient application of new materials ✓
- Strategic application of lightweight materials with direct customer benefit ✓

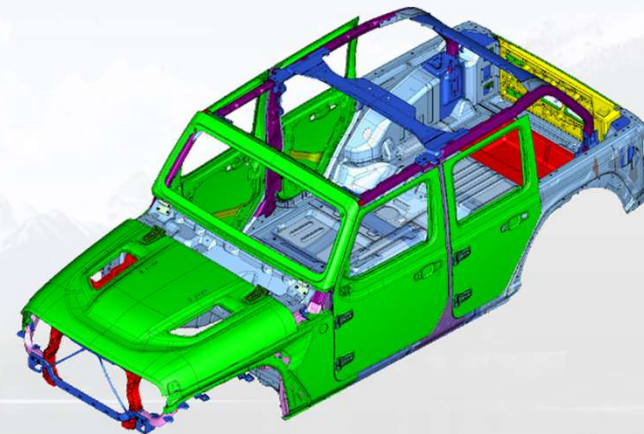

All-New Jeep® Wrangler Media Quotes

Jeep®

“The new Jeep [Wrangler] is full of creative solutions...that make it **more modern without compromising its iconic character or capability.**”

AutoGuide
.com

“The JL **lives up to the tradition** of its predecessors, **but is enhanced with features** that don't detract from its mission as the definitive off-roader.”

autoblog

“In the 2018 Wrangler JL, we're looking at an all-new truck that **refines and evolves** what was already an immensely popular, incredibly capable product **without losing the distinctive plot** that made it so dang popular and capable in the first place.”

AUTOWEEK

“The 2018 Jeep Wrangler is here, and...it's **still everything we hoped for—and more.**”

MOTOR AUTHORITY

“Jeep [Brand] will make **Wrangler ownership an easier experience without sacrificing** the ability that many Wrangler owners require in their rig.”

cars.com

“Everything that makes people exuberantly, irrationally love the Wrangler is still here. It's just been finessed in a way that won't jostle a die-hard's sensibilities.”

ROAD & TRACK

“The process of stowing the soft top has been streamlined to the point that the chance of... offending bystanders with profanity in the pursuit of sun worship is now nearly eliminated.”

CAR AND DRIVER

“The people on the Jeep team who fought for the integrity of the Wrangler deserve kudos, because without their good fight we'd be talking about a Wrangler in name only; a steel-roofed SUV with IFS and potentially the death of a beloved brand..”

FOURWHEELER

WRANGLER JL

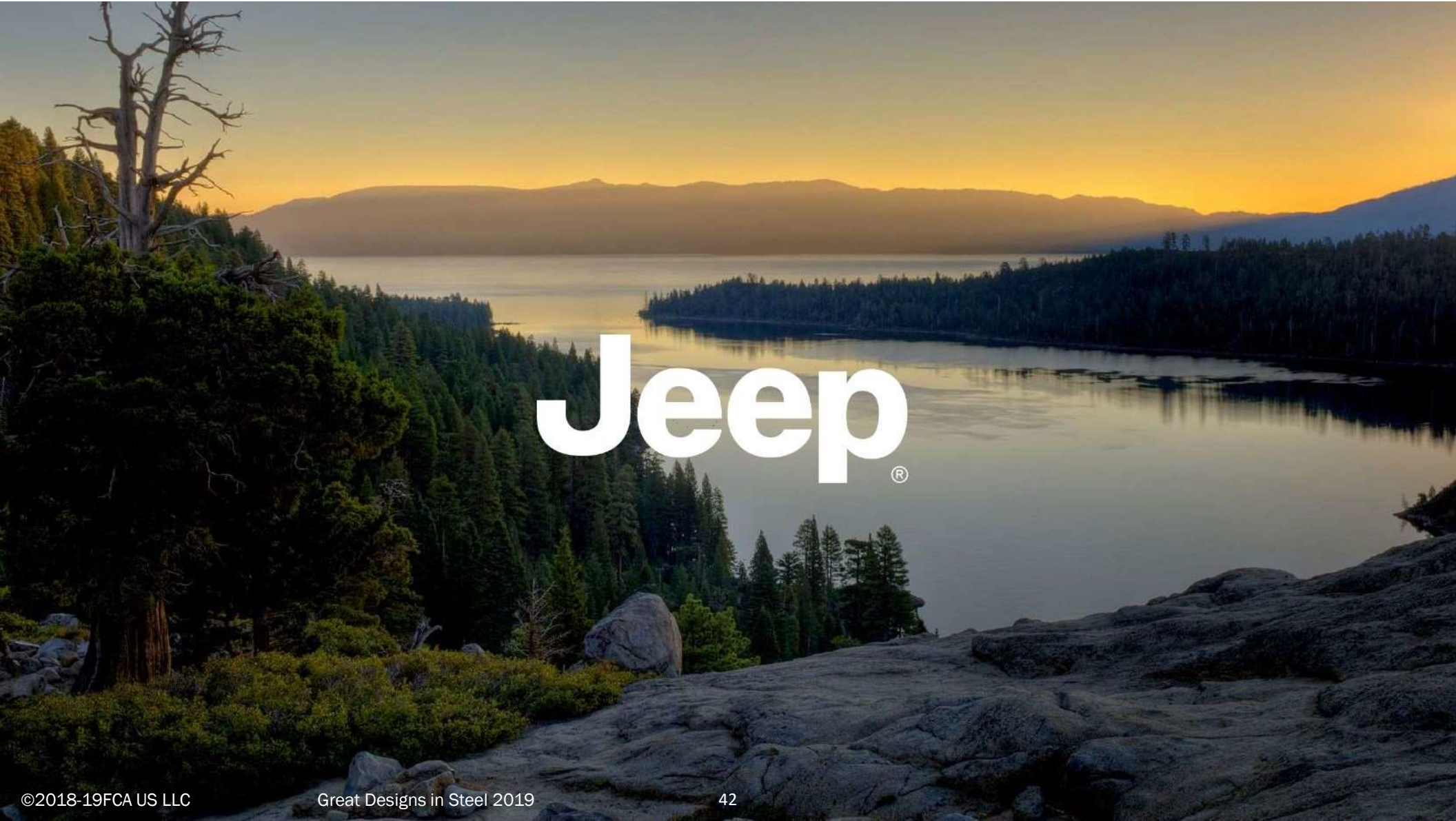

Jeep®

Jeep[®]

©2018 FCA US LLC. All Rights Reserved.
Jeep is a registered trademark of FCA US LLC

GREAT DESIGNS IN STEEL

**Presentations will be available for
download on SMDI's website on
Wednesday, May 22**