

**THE REFORM MYTH:
HOW CHINA IS USING STATE POWER TO CREATE
THE WORLD'S DOMINANT STEEL INDUSTRY**

Prepared for:

The American Iron & Steel Institute

The Steel Manufacturers Association



Prepared by:



Alan H. Price, Esq.
Timothy C. Brightbill, Esq.
Christopher B. Weld, Esq.
Tessa V. Capeloto, Esq.

October 2010



Wiley Rein LLP
1776 K Street NW
Washington, DC 20006

TABLE OF CONTENTS

	Page
I. INTRODUCTION	2
II. THE GROWTH AND EVOLUTION OF THE CHINESE STEEL INDUSTRY	4
III. CHINESE GOVERNMENT OWNERSHIP AND CONTROL OF THE STEEL INDUSTRY	5
A. Chinese Government Ownership of the Steel Industry Continues to Increase Despite China’s WTO Commitments Regarding Market Reforms	5
B. The Government Manages and Controls Virtually Every Aspect of the Steel Industry Through Policy Directives and Foreign Investment Restrictions	10
1. China’s Industrial Plans and Other Policy Directives for the Steel Industry	11
2. Restrictions on Foreign Investment	17
3. Raw Material Restrictions.....	19
C. Conclusion	22
IV. THE ACCELERATION OF CHINA’S GOING ABROAD STRATEGY	22
A. China’s Going Abroad Policy Framework	22
1. 2009 Steel Adjustment and Revitalization Plan.....	23
2. June 2010 State Council Policy	24
3. Five-Year Plans.....	24
B. Going Abroad Pursuant to Government Policies.....	25
1. Securing Access to Raw Materials	27
2. SOE Investment in the U.S. Steel Industry – The Anshan Example	30
3. Implications for the United States.....	31
V. CONCLUSION.....	32
VI. APPENDIX 1.....	33

THE REFORM MYTH: HOW CHINA IS USING STATE POWER TO CREATE THE WORLD'S DOMINANT STEEL INDUSTRY

I. INTRODUCTION

The unprecedented growth of the Chinese steel industry continues to defy market forces. Indeed, China has captured all of the world's growth in steel production over the last decade. From 2000 to 2009, Chinese steel production increased by 346 percent, while steel production in the rest of the world decreased by 10 percent.¹ Today, China's total steel production is on pace to be as much as 630 million metric tons per year, accounting for more than 45 percent of global steel production.²

This unparalleled expansion has been facilitated by massive government intervention. For years, the Chinese government has owned, directed, and subsidized virtually every aspect of the Chinese steel industry. Today, in violation of its commitments regarding market reforms made upon accession to the World Trade Organization ("WTO") in 2001, the Chinese government continues to exercise considerable ownership and control over its steel industry. In addition to owning majority shares in most of its major steel producers, the Chinese government maintains a high degree of decision-making authority over the steel industry and continues to intervene extensively in the operations of individual steel companies. As a result, more than ever before, China's steel producers are operating in an environment where basic market forces do not exist or apply, and where commercial decisions are mandated by the government – a clear violation of China's WTO commitment to "not influence, directly or indirectly, commercial decisions on the part of state-owned or state-invested enterprises."³

Two earlier reports, *The China Syndrome: How Subsidies and Government Intervention Created the World's Largest Steel Industry* (July 2006) and *Money for Metal: A Detailed Examination of Chinese Government Subsidies to the Steel Industry* (July 2007) describe the various ways in which the Chinese government provides direct and indirect benefits to the steel industry, including cash grants, land grants, transfers of ownership interests, conversions of debt to equity, debt forgiveness, preferential loans, and tax incentives. These reports demonstrate that the Chinese government has provided – and continues to provide – massive amounts of financial assistance to China's steel industry, in violation of its WTO commitments to abide by the Agreement on Subsidies and Countervailing Measures ("SCM Agreement").⁴ The result of these enormous subsidies is that China's steel exports, particularly exports to the United States, have

¹ *World Steel in Figures 2010*, World Steel Association, July 2010.

² *Crude Steel Production*, World Steel Association (data is annualized), July 2010.

³ *Report of the Working Party on the Accession of China*, World Trade Organization, WT/M1N(01), at par. 46, November 10, 2001, ("Working Party Report").

⁴ With respect to subsidies, China agreed to "eliminate all export subsidies, within the meaning of Article 3.1(a) of the SCM Agreement, by the time of accession." Working Party Report, at par. 167. Upon accession, China would "cease to maintain all pre-existing export subsidy programmes, and, upon accession, make no further payments or disbursements, nor forego revenue or confer any other benefit, under such programmes." *Id.* In addition, China committed to "eliminate, upon accession, all subsidies contingent upon the use of domestic over imported goods, within the meaning of Article 3.1(b) of the SCM Agreement." *Id.*, at par. 168.

increased significantly during the past decade. With its total steel production now more than eight times larger than that of the U.S. steel industry, China's exports to the United States and the rest of the world will only increase.

This report further examines the Chinese government's ownership and control over its steel industry. New data demonstrate that the government's ownership of its steel producers continues to increase. By the end of 2009, eight of the ten largest Chinese steel groups were 100 percent owned and controlled by the Chinese government, while 16 of the top 20 steel groups were 100 percent owned and controlled by the government.⁵ More than 95 percent of the production of the top 20 steel groups was subject to some government ownership.

In addition to ownership stakes, this report reviews the Chinese government's industrial plans and other policy directives that permit the government to intervene extensively in the operations of individual steel companies. Since 2005, the government has issued a number of industrial plans specifically covering the steel industry that have significantly increased the government's control over the development of the industry. The plans include the 2005 Steel and Iron Industry Development Policy, the 2009 Steel Adjustment and Revitalization Plan, and the June 2010 State Council Policy. These policies permit the Chinese government to manage virtually every aspect of the steel industry, in direct violation of China's WTO commitments to refrain from influencing the decisions of its state-owned enterprises ("SOEs") and to permit SOEs to operate based solely on commercial considerations.

Pursuant to these industrial plans, the Chinese government has created the world's largest steel industry. As the next step in its industrial strategy, China is now pursuing its "Going Abroad" strategy, deploying its massive "national champions" overseas to further the government's objectives, which include exploiting natural resources and raw materials, obtaining technology and expertise, and increasing China's economic and political influence on a global scale. In addition to raw materials, the Chinese government is beginning to deploy its state-owned national champions overseas to invest in downstream industries such as the steel industry. This report examines the potential dangers faced by the United States and other countries as a result of China's Going Abroad strategy, including the market distortions and national security concerns resulting from the Chinese government's intervention in private markets. Chinese investment pursuant to the Going Abroad strategy will force private U.S. steel companies to compete directly against government-owned and supported companies in the U.S. marketplace, creating significant imbalances that will further distort the steel market.

China's expansion abroad, and the extent of its steel production growth, are not the result of free markets and comparative advantage. While the Chinese steel industry would be large absent government support, massive government intervention has played a substantial role in the industry's growth. Indeed, China has reached its position through a combination of subsidies, mandates, and planned government intervention – at the expense of market-oriented producers around the globe, including those in the United States.

⁵ Ownership information focuses on Chinese government ownership of steel companies at the holding company or "group" level.

II. THE GROWTH AND EVOLUTION OF THE CHINESE STEEL INDUSTRY

The unprecedented growth of China's steel industry is inconsistent with commercial considerations. As shown in Chart 1 below, from 2000 to 2009, Chinese steel production increased by approximately 350 percent, growing from 127.2 million metric tons to 567.8 million metric tons, even though steel production in the rest of the world decreased by 10 percent.⁶ As these figures indicate, China's growth has come at the expense of the rest of the global steel industry – China's share of world production jumped from 15 percent in 2000 to 46 percent in 2009.⁷

CHART 1

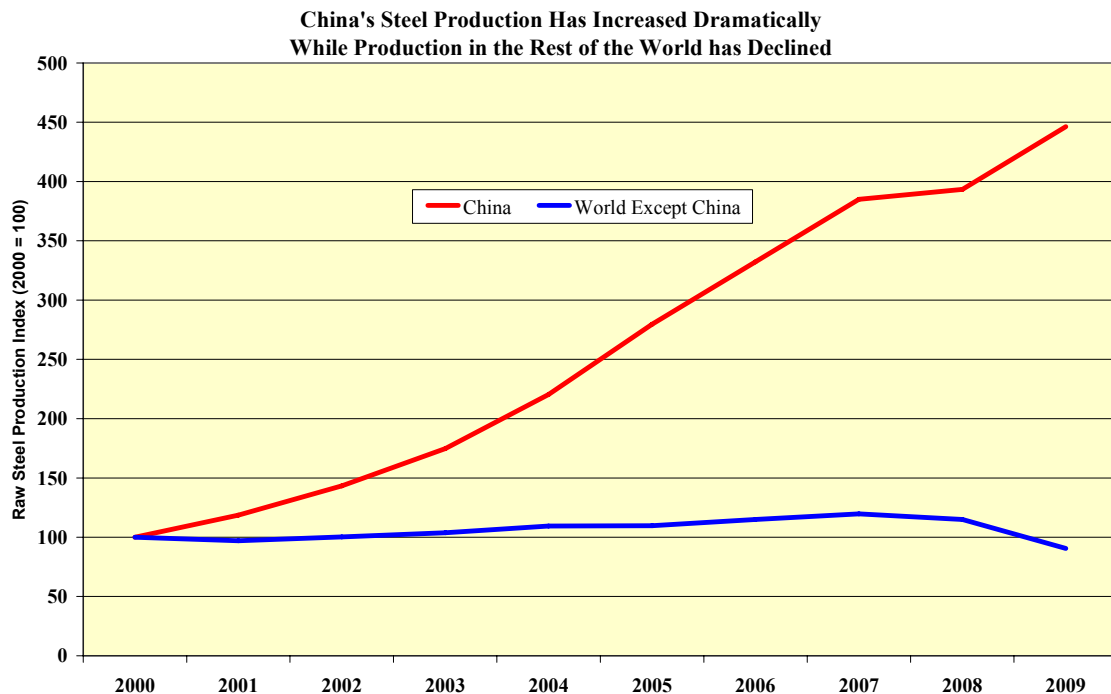

Source: World Steel Association.

Over the last decade, China's crude steel production increased by 440.6 million metric tons.⁸ To put this figure into perspective, from 2003 to 2009, average crude steel production in the United States was 90.6 million metric tons.⁹ In other words, over the last decade, China's steel production has *increased* by a volume of almost five times the average annual *total* production of the U.S. industry.¹⁰

⁶ *World Steel in Figures 2010*, World Steel Association, July 2010.

⁷ *Id.*

⁸ $567.8 - 127.2 = 440.6$.

⁹ World Steel Association data, available at <http://worldsteel.org>.

¹⁰ $440.6 / 90.6 = 4.86$.

Furthermore, despite the significant increase in Chinese steel consumption, China's growth in steel production has far outpaced consumption. In 2003, China's net *imports* of steel were 34.65 million metric tons.¹¹ World Steel Dynamics estimates that China's net *exports* of steel products will be 30.35 million metric tons this year.¹² These two figures reflect a shift in China's steel trade balance of *65 million metric tons*.¹³ It is beyond question that this dramatic shift has caused untold disruption in the U.S. and other markets worldwide, as demonstrated by the growing number of disputes and increased trade tensions between China and its trading partners.

China's growth in steel production has not been based on commercial considerations. Rather, the Chinese steel industry is a creation of the state. Its unparalleled expansion is the direct result of massive intervention by the Chinese government and has negatively affected production in other markets. Such expansion would not have been possible but for the Chinese government's overwhelming ownership and control of the steel industry, and the government's provision of an extraordinary range of subsidies and other support to Chinese steel producers. These subsidies have caused serious prejudice to market-based producers in the rest of the world, including reduced capacity expansion, production, sales, and profits.

III. CHINESE GOVERNMENT OWNERSHIP AND CONTROL OF THE STEEL INDUSTRY

The Chinese government continues to exercise considerable government ownership and control over its steel industry. In addition to owning majority shares in almost all of its major steel producers, the Chinese government maintains a high degree of decision-making authority over the steel industry and continues to intervene extensively in the operations of individual steel companies. In fact, the government's ownership and control of the steel industry has grown dramatically since China's accession to the WTO in 2001, and continues to increase, despite its commitments regarding market reforms. Any progress China may be making towards a market-oriented economy has been notably absent with respect to its steel industry, which remains overwhelmingly government-owned, -controlled, and -supported.

A. Chinese Government Ownership of the Steel Industry Continues to Increase Despite China's WTO Commitments Regarding Market Reforms

Upon accession to the WTO, China agreed to a number of market reforms and other measures designed to ensure compliance with its WTO commitments and core WTO values. These commitments, set forth in China's Protocol of Accession and the accompanying Working Party Report, include eliminating government influence from the decision-making of SOEs and ensuring that these entities operate based solely on commercial principles.¹⁴ Specifically, in paragraph 46 of the Working Party Report, China committed to "ensure that all state-owned and

¹¹ Peter F. Marcus and Karlis M. Kirsis, *Core Report ZZZZ: Global Steel Export Pricing Forecast to 2015*, World Steel Dynamics, at 23, July 2007.

¹² *Truth & Consequences # 57*, World Steel Dynamics, at 22, Sept. 14, 2010.

¹³ $34.65 + 30.35 = 65$.

¹⁴ *See e.g.*, Working Party Report, at par. 46.

state-invested enterprises would make purchases and sales based solely on commercial considerations,” and that it “would not influence, directly or indirectly, commercial decisions on the part of state-owned or state-invested enterprises.”¹⁵ Despite these commitments, government ownership and control of the steel industry continue to increase.

The Chinese Government’s 10th Five-Year Plan for National Economic and Social Development establishes the framework for state ownership of the steel industry by requiring that the “state must hold a controlling stake in strategic enterprises that concern the national economy.” Because the iron and steel industry is considered a “strategic” or “pillar” industry, the Chinese steel industry remains predominately state-owned, with the government owning the vast majority of shares in almost all of China’s major steel producers. Indeed, in 2007, 91 percent of the production of the top 20 steel groups was state-owned and controlled.¹⁶ As the table below indicates, by the end of 2009, more than 95 percent of the production of the top 20 steel groups was subject to some government ownership. Moreover, for the reasons discussed below, government ownership of China’s steel industry will likely continue to increase.

TABLE 1¹⁷
OWNERSHIP OF THE TOP TWENTY CHINESE STEEL GROUPS

Rank	Producer	2009 Prod. (Million MT)	Owner/Majority Shareholder	% Govt. Ownership
1	Hebei Iron & Steel Group	40.24	Hebei Province SASAC*	100.00
2	Baosteel Group	38.87	Central SASAC	100.00
3	Wuhan Iron and Steel Group	30.35	Central SASAC	100.00
4	Anben Iron & Steel Group (Anshan)	29.18	Central SASAC and Liaoning Province SASAC	100.00
5	Shagang Group	26.38	Runyuan Trading Co. (17.4%), 39 individuals (64%), and Jiangsu Shagang Group Labor	18.60

¹⁵ *Id.*

¹⁶ See *Money for Metal: A Detailed Examination of Chinese Government Subsidies to the Steel Industry*, Wiley Rein, LLP, at 8-10, July 2007 (“Money for Metal”), available at <http://www.wileyrein.com/resources/documents/pu4411.pdf>.

¹⁷ See *China’s Top 20 Steel Mills Ownership Structure*, Steel Business Briefing, July 2010. Ownership and production information contained in Table 1 is current through the end of 2009. The table focuses on Chinese government ownership of steel companies at the holding company or “group” level.

¹⁸ Labor unions in China are not independent, but rather are controlled by the Chinese Communist Party (“CCP”) and are therefore treated as government-controlled entities for purposes of this chart. According to the U.S. State Department: “[I]n practice workers were not free to organize or join unions of their own choosing. The All-China Federation of Trade Unions (ACFTU), which was controlled by the CCP and chaired by a member of the Politburo, was the sole legal workers’ organization. The trade union law gives the ACFTU control over all union

Rank	Producer	2009 Prod. (Million MT)	Owner/Majority Shareholder	% Govt. Ownership
			Union (18.6%) ¹⁸	
6	Shandong Iron & Steel Group	21.31	Shandong Province SASAC	100.00
7	Shougang Group	17.29	Central SASAC	100.00
8	Xinwu'an Group	16.71	Wenfeng I&S Group, Puyang I&S Co., Xinghua I&S Co., and 9 other mills (83.74%); and Wu'an City SASAC (16.26%)	16.26
9	Magang Group (parent of Maanshan Steel)	14.83	Anhui Province SASAC	100.00
10	Valin Iron & Steel Group	11.81	Hunan Province SASAC	100.00
11	Baotou Iron & Steel Group	10.07	Inner Mongolia SASAC	100.00
12	Rizhao Iron & Steel Holding Group	9.91	Shandong Province SASAC	100.00
13	Taiyuan Iron & Steel Group	9.46	Shanxi Province SASAC	100.00
14	Anyang Iron & Steel Group	8.50	Henan Province SASAC	100.00
15	Beijing Jianlong Heavy Industry Group	8.38	Fosun Group, Mr. Zhang Zhixiang	0.00
16	Panzhuhua Iron & Steel Group	8.18	Central SASAC	100.00
17	Jiuquan Iron & Steel Group	7.59	Gansu Province SASAC	100.00
18	Tangshan Guofeng Iron & Steel Group	7.58	Central SASAC (51%) ¹⁹ and Tangshan City, Fengnan County	100.00

organizations and activities, including enterprise-level unions, and requires the ACFTU to ‘uphold the leadership of the Communist Party.’ Independent unions are illegal. In some cases the ACFTU and its constituent unions influenced and implemented government policies on behalf of workers; however, the CCP used the ACFTU to communicate with and control workers.” *Country Report on Human Rights Practices 2006, China*, U.S. State Dep’t, at Section 6(a), 2007, available at <http://www.state.gov/g/drl/rls/hrrpt/2006/78771.htm>.

¹⁹ Tangshan Guofeng Iron & Steel Group (“Tangshan”) is 51 percent owned by China Travel Services (Holdings) Hong Kong Co., which, in turn, is 100 percent owned by the central government State-owned Assets Supervision and Administration Commission of the State Council (“SASAC”). Tangshan is also 49 percent owned by the Tangshan City, Fengnan County SASAC.

Rank	Producer	2009 Prod. (Million MT)	Owner/Majority Shareholder	% Govt. Ownership
			SASAC (49%)	
19	Beitai Iron & Steel Group	6.88	Liaoning Province SASAC	100.00
20	Jinxi Iron & Steel Group	6.83	China Oriental Group	0.00
* State-owned Assets Supervision and Administration Commission of the State Council (“SASAC”)				

As Table 1 demonstrates, eight of the ten largest Chinese steel groups are 100 percent owned and controlled by the Chinese government, while 16 of the top 20 steel groups are 100 percent owned and controlled by the government. In terms of production, the vast majority of the top 20 steel groups is subject to some level of state ownership. For a breakdown of the ownership of the four largest producers, see **Appendix 1**.

This massive degree of state ownership allows the government to exercise extensive control over the steel industry and enables the government to direct steel producers to act in ways that further governmental aims, such as maximizing tax revenue and employment, rather than responding to market signals. In addition, as discussed below, these high levels of state ownership make it significantly easier for the government to implement and enforce its industrial policies relating to the steel industry.

Table 1 also demonstrates the degree to which Chinese steel companies are owned by the various levels of the Chinese government: central, provincial, and local (county or municipal). Of the top 20 Chinese steel producers, six are partly or wholly owned by the central government, 11 are partly or wholly owned by a provincial government, and two are partly owned by a local government. Some companies, such as Anben, are jointly owned by the central government and a provincial government.

Moreover, Chinese government ownership of the steel industry is even more pervasive than the above table indicates. Many of China’s purportedly “private” steel producers are substantially owned and controlled by the Chinese government.²⁰ For example, the Shagang Group, the fifth largest steel producer in China, claims to be the country’s largest privately owned steel producer. However, Chinese government ownership in the enterprise is significant. The firm was formed in 1975 as a village enterprise,²¹ and changed its name to Jiangsu Shagang Group in 1995. The firm’s ownership status changed in 2001, during a period of asset-stripping management buyouts in the Chinese steel industry. Approximately 17 percent of the firm was purchased by the plant general manager and 25 percent of the firm was sold to the Jiangsu

²⁰ Even for Chinese steel companies that are truly privately owned, the government maintains considerable control and direction over these entities through ties to company management, subsidies, government industrial policies and directives, and other forms of manipulation and coercion. For additional information regarding China’s so-called “private” steel companies, see *Government Ownership and Control of China’s “Private” Steel Producers*, Wiley Rein LLP, October 2007, available at <http://www.wileyrein.com/resources/documents/pu4444.pdf>.

²¹ Liu Weiling and Diao Ying, *Man of Steel*, China Daily, August 13, 2007.

Province SASAC.²² An additional 23 percent went to the company's labor union, which is controlled by the Chinese Communist Party,²³ and almost 35 percent went to the "employees of Shagang." That same year, the firm doubled its capacity by acquiring a German mill and reassembling it in China. In 2006, Shagang acquired Huaigang, a specialty steel producer whose ownership has at various times included the municipal government of Huai'an, the provincial government of Jiangsu, and the Nanjing Iron & Steel Group, which is owned by the Jiangsu Province SASAC.²⁴ In short, even China's largest "privately" owned producer is substantially state-owned, and appears to have received capital inflows from the state in the same year that its capacity doubled.

The Chinese government also exerts significant control over the companies in which it has only partial ownership. In many companies in which the government is a partial owner, the private entity owns only a small minority of a separate class of non-tradable shares.²⁵ The fact that some companies are partially publicly owned is of little consequence due to the lack of rights accorded minority shareholders. Indeed, it is widely recognized that majority shareholders (generally the government) "routinely run roughshod over minority shareholders" and that China's legal system has proven unable to protect minority shareholder rights.²⁶ As one study recently concluded, "[t]here is little or no opportunity for minority shareholders to exercise their voice and oppression of minority shareholders is a serious issue in practice."²⁷ The government also exerts significant control over the companies in which it has only partial ownership through its ties to company management, subsidies, and government industrial policies and directives.

While debate about whether China is transitioning to a market-oriented economy persists, it is clear that market principles will not penetrate China's steel industry to any significant degree in the near future given the overwhelming degree of government ownership in the industry. In fact, as noted above, government ownership of the steel industry appears to be increasing, not decreasing. Moreover, because of government-mandated consolidations – which generally

²² The remaining ownership was split between employees and the firm's labor union. Labor unions in China are not independent, but controlled by the Chinese Communist Party. *See* fn. 21.

²³ *See* fn. 21.

²⁴ *See* Jiangsu Shagang Group Huaigang Special Steel Co. Ltd. website, available at <http://www.huaigang.com/about1.asp>.

²⁵ *See* James Ahn and David Cogman, *A Quiet Revolution in China's Capital Markets*, McKinsey on Finance, at 1, Summer 2007.

²⁶ *Corporate Governance Can Drive China's Reform*, The Asian Wall Street Journal, November 22, 2002. *See also Reforming State Asset Management and Improving Corporate Governance: The Two Challenges of Chinese Enterprise Reform*, OECD, at 9, February 3, 2005, ("The most widespread abuse is asset stripping by controlling 'legal entity' shareholders at the expense of the firm itself and its minority shareholders through abusive related party transactions among firms of the same group, intra-group lending or guarantees, and excessive cash dividends. Indeed, the parent company will typically transfer productive assets to its listed subsidiary, retaining liabilities and redundant staff, and while remaining an SOE").

²⁷ Jin ZhuYang, *Shareholder Meetings and Voting Rights in China: Some Empirical Evidence*, Int'l Co. and Commercial L. Rev., at 11, 2007.

involve the acquisition of smaller, potentially private companies by larger SOEs – government ownership of the industry will continue to increase.²⁸

Finally, the central government has made it abundantly clear that it has no intention of relinquishing ownership and control over the steel industry. Indeed, because steel has been designated as a strategic industry, the central government has indicated that it plans to retain substantial influence in the sector. For example, in December 2006, the central government SASAC issued the “Guiding Opinion Concerning the Advancement of Adjustments of State Capital and the Restructuring of State-Owned Enterprises,” which identifies sectors deemed to be critical to the national economy. This measure indicates that the government must maintain strong state control over “pillar” and “backbone” industries such as iron and steel.²⁹ Similarly, the October 2008 “Law on State-owned Assets of Enterprises” was implemented to further enable SOEs to play a dominant role in the national economy, especially in key sectors, and to promote the development of China’s “socialist market economy.”³⁰ These provisions are directly at odds with the letter and spirit of China’s WTO commitments to “not influence, directly or indirectly, commercial decisions on the part of state-owned or state-invested enterprises.”³¹

B. The Government Manages and Controls Virtually Every Aspect of the Steel Industry Through Policy Directives and Foreign Investment Restrictions

The Chinese government continues to exercise extensive control over the development of the Chinese steel industry, not only through its ownership stakes, but also through a number of policy instruments which afford the government substantial leverage to direct the growth and evolution of the industry. In fact, since 2005, the government has issued a number of industrial plans and other policy directives specifically covering the steel industry that have *significantly increased* the government’s pervasive control over the development of the industry. All three levels of the Chinese government – central, local, and provincial – have issued industrial plans that designate steel as a preferred industry and eligible for a wide variety of government subsidies and other benefits. Moreover, the Chinese government has pursued foreign investment restrictions, which provide yet another mechanism for the government to control the direction and development of China’s steel industry. As detailed below, these policy instruments and foreign investment restrictions permit the Chinese government to manage and control virtually every aspect of the steel industry, including raw material prices, in direct violation of China’s

²⁸ The Chinese government is aiming to consolidate more than 60 percent of its total steel capacity in the hands of its top 10 steel producers by 2015, up from 44 percent in 2009. *See Consolidation Target for Top Steel Mills*, Reuters, June 2010. Eight of the ten largest Chinese steel groups are 100 percent owned and controlled by the Chinese government. Government ownership of the steel industry will thus likely increase through these forthcoming consolidations.

²⁹ *See USTR Report to Congress on China’s WTO Compliance*, at 60-61, December 2009, (“USTR Report on WTO Compliance”), available at <http://www.ustr.gov/about-us/press-office/press-releases/2009/december/ustr-releases-2009-report-congress-chinas-wto-com>.

³⁰ *See id.*, at 60.

³¹ Working Party Report, at par. 46.

WTO commitments to refrain from influencing the decisions of its SOEs and to permit SOEs to operate based solely on commercial considerations.

1. China's Industrial Plans and Other Policy Directives for the Steel Industry

The Chinese government continues to maintain a high degree of decision-making authority over the management and development of the steel industry, as demonstrated by the numerous industrial plans and other policy directives covering the steel industry. With each successive policy, the government has asserted even more authority to intervene in and direct the course of the steel industry.

a. **The 2005 Steel Policy**

China's policy framework for the steel industry is set forth in the July 2005 Steel and Iron Industry Development Policy ("Steel Policy"), issued by the National Development and Reform Commission ("NDRC").³² The Steel Policy provides for government control of almost every aspect of the steel industry, including resource and equipment utilization, regional output levels, quality improvements, technological innovation, investment management, and consolidation. Specifically, the Steel Policy:

- provides for the reorganization of China's largest steel producers to create an industry with two 30 million-ton steel groups and several 10 million-ton steel groups by 2010;³³
- prescribes the number and size of steel producers, their location, the type and mix of products that are permitted to be produced, and even minute details relating to the technology that will be used (*e.g.*, size and composition of blast furnaces); and
- mandates direct government subsidization of the steel industry. For example, it provides for government support in the form of "tax refunds, discounted interest rates, funds for research and other policy support for major iron and steel projects utilizing newly developed domestic equipment."³⁴ The policy also encourages indirect government support by, among other things, restricting foreign investment, discriminating against foreign equipment and technology, and providing various export credits.

In short, China's Steel Policy is a primary example of the government's attempt to dictate industry outcomes and involve itself in decisions that should be made by the market. As the United States Trade Representative ("USTR") has concluded:

China's 2005 steel policy is also striking because of the extent to which it attempts to dictate industry outcomes and involve the

³² *Order No. 25 of the National Reform and Development Commission*, Steel and Iron Industry Development Policy, at Art. 20, July 2005, ("Steel Policy").

³³ *Id.*, at Art. 20. The Chinese steel industry has exceeded this goal. *See* Table 1.

³⁴ *Id.*, at Art. 16.

government in making decisions that should be made by the marketplace. This high degree of government direction regarding the allocation of resources into and out of China's steel industry raises concerns not only because of the commitment that China made in its WTO accession agreement that the government would not influence, directly or indirectly, commercial decisions on the part of state-owned or state-invested enterprises, but also more generally because *it represents another significant example of China reverting to a reliance on government management outcomes instead of moving toward a reliance on market mechanisms*. Indeed, it is precisely that type of *regressive approach* that is at the root of many of the WTO compliance concerns raised by U.S. industry.³⁵

Since the issuance of the Steel Policy in 2005, the Chinese government has only increased its control over the steel industry. Indeed, recent government policies allow for an even greater degree of government control over the direction of the steel industry and the operation of individual steel enterprises.

b. The 2009 Steel Adjustment and Revitalization Plan

In March 2009, China's Ministry of Industry and Information Technology issued an update to the Steel Policy entitled the Steel Adjustment and Revitalization Plan ("Revitalization Plan").³⁶ The Revitalization Plan sets forth a wide range of policies and measures to be implemented by each region in China in order to ensure that China's "mainstay industry," the steel industry, successfully weathers the effects of the international financial crisis, and to satisfy Communist Party and State Council requirements for the development and growth of the industry. As with the Steel Policy, the Revitalization Plan provides for massive government intervention in the Chinese steel industry. Specifically, the Revitalization Plan:

- dictates the structure and direction of various aspects of the industry, including resource and equipment utilization, import and export tax rates, production capacity, technological innovation, enterprise reorganization, and product development;
- calls for the strict control of "backward" production capacity by identifying the equipment and capabilities that must be eliminated, and specifies steel products that should be produced, the industries for which steel products should be developed, and the locations where steel plants should be constructed or relocated;
- mandates the reorganization and consolidation of specific Chinese steel producers, primarily through mergers and acquisitions. For example, the

³⁵ USTR Report on WTO Compliance, at 69 (emphasis added).

³⁶ Gov't of the PRC Steel Adjustment and Revitalization Plan, March 23, 2009.

revitalization plan calls for the “substantial reorganization” of Anben Iron and Steel Group (or “Anshan”), Guangdong Steel Group, Guanxi Steel Group, Hebei Steel Group, and Shandong Steel Group. In addition, it states that large steel enterprises such as Baosteel, Anshan, and Wuhan Steel must reach a production capacity of over 50 million metric tons by 2011, and further requires the establishment of “several large-sized enterprises with the productive capacity of 10-30 million tons;” and

- provides for direct and indirect government subsidization of the steel industry through various measures, including tax reimbursements for exports, loans for technical improvements and research and development, and export credits for metallurgical equipment.

The provisions of these industrial policies are not mere recommendations – they are requirements with which individual steel producers must comply. For example, the government’s push for the “substantial reorganization” of the steel industry is already well under way. In 2008, the merger of the Tangshan Steel Group and Handan Steel Group resulted in the formation of the largest steel producer in China, Hebei Iron and Steel Group.³⁷ In September 2009, Shandong Iron and Steel Group signed an agreement to take over closely held Rizhao Iron and Steel Holding Group.³⁸ As yet another example, in 2008, the merger between Anshan Iron and Steel Group and Benxi Iron and Steel Group resulted in the establishment of Anben Iron and Steel Group. In recent months, Anshan has taken steps towards additional mergers that will result in the creation of an even larger enterprise – as specified in the Revitalization Plan. Specifically, in May 2010, the central SASAC approved the consolidation of Anshan and Panzhihua Iron and Steel Group.³⁹ Moreover, in June 2010, Benxi Iron and Steel Group signed an agreement to merge with Beitai Iron & Steel Government.⁴⁰ Once these two mergers are finalized, Anshan will have a steel production capacity of approximately 60 million tons⁴¹ – again, all according to central government plans.

c. June 2010 State Council Policy

In June 2010, China’s chief administrative body, the State Council, released its “Advice for the Promotion of Energy Saving, Emissions Reduction and Industrial Structure Adjustment” (“State Council Policy”).⁴² The State Council Policy includes a variety of provisions intended to direct the growth and development of the steel industry. For example, the State Council policy:

³⁷ See *China’s Top 20 Steel Mills Ownership Structure*, Steel Business Briefing, July 2010.

³⁸ *Shandong Iron Acquires Rizhao Steel Through Venture*, Bloomberg News, September 7, 2009, available at http://www.bloomberg.com/apps/news?pid=newsarchive&sid=a_ZaNgSyZNV8.

³⁹ See *China’s Top 20 Steel Mills Ownership Structure*, Steel Business Briefing, July 2010.

⁴⁰ See *id.*

⁴¹ See *id.*

⁴² State Council’s “Advice for the Promotion of Energy Saving, Emissions Reduction and Industrial Structure Adjustment,” June 17, 2010, (“State Council Policy”).

- provides for measures to accelerate the reorganization and consolidation of the industry, with the goals of: (i) creating 3-5 massive steel groups with international competitiveness; (ii) increasing the percentage of total production of the top 10 steel companies from 44 percent in 2009 to 60 percent in 2015; and (iii) eliminating outdated capacity;
- calls for measures to enhance the technological innovation and transformation of the steel industry, as well as measures to control the export and import of specific steel products; and
- mandates subsidies and other government support such as land usage, loans, credit, and capital market financing to achieve these ends.⁴³

Each of the above-referenced policies has been implemented *since* China’s accession to the WTO, and, with each successive policy, the government has asserted even more authority to intervene in and direct the course of China’s steel industry. As a result, China has failed to abide by its WTO obligations that are contained in paragraph 46 of the Working Party Report. It has failed to refrain from “influencing, directly or indirectly, commercial decisions on the part of state-owned or state-invested enterprises”⁴⁴ and from permitting SOEs to operate based solely on commercial considerations. To the contrary, China continues to intervene heavily in the decision-making of its steel-producing SOEs in a manner that is inconsistent with the WTO agreements. In fact, USTR itself has concluded that “[t]he Chinese government has heavily intervened in the investment decisions made by state-owned and state-invested enterprises,” including “decisions related to their strategies, management and investments,”⁴⁵ and that China’s steel policies include “guidelines that appear to conflict with [China’s] WTO obligations.”⁴⁶

d. Other Government Industrial Plans

(i) Central Government Five-Year Plans

The Chinese government also exercises control over the growth and direction of the steel industry through five-year industrial plans. Issued by the Central Committee of the Communist Party of China, the five-year plans set forth which industries, enterprises, and products should be targeted for preferential government support and specifically enumerate the types of preferences to be provided such industries. According to the government, five-year plans aim to “arrange national key construction projects, manage the distribution of productive forces and individual sector’s contributions to the national economy, map the direction of future development, and set targets.”⁴⁷ These plans serve as economic and industrial instructions for planning agencies, local and provincial governments, banks, and SOEs.

⁴³ *Id.*

⁴⁴ Working Party Report, at par. 46.

⁴⁵ USTR Report on WTO Compliance, at 60.

⁴⁶ *Id.*, at 65.

⁴⁷ See *What is the Five-Year Plan*, China.org.cn, available at <http://www.china.org.cn/english/MATERIAL/157595.htm>.

The 10th Five-Year Plan for National Economic and Social Development, covering the period 2001-2005, prescribed “energetically optimizing and improving [the] industrial sector” by enhancing traditional industries with new technologies and intensifying construction of transportation, energy and other infrastructure facilities.⁴⁸ According to the plan, these measures were “most important in the energy [and] metallurgy” industries.⁴⁹ Acknowledging the overbuilding of steel capacity during the 2000-2005 period, the central government’s 11th Five-Year Plan, covering the period 2006-2010, focuses on capacity consolidation, along with the creation of new, high-efficiency steel facilities that can compete on a global scale. Specifically, the plan provides for improving the quality of steel products through the acquisition of new technology and equipment as well as consolidating the industry through mergers to create larger and more internationally-competitive steel companies.⁵⁰ In other words, the plan acknowledges that China’s rapid growth in steel production is not intended for domestic use, but will result in increased exports.

The central government’s 12th Five-Year Plan, covering the period 2011-2015, is expected to be passed at the Fifth Plenary Session of the 17th Chinese Communist Party Committee meeting scheduled for the Fall of 2010.⁵¹ While details of this plan have yet to be released, given the nature of the previous five-year plans, the 12th Five-Year Plan will likely continue the trend of increased government control over the steel industry.

(ii) Provincial Government Five-Year Plans

Similar to the central government’s five-year plans, the provincial plans identify the industries and products to be targeted for preferential government support.⁵² The five-year plan of almost every province in China establishes the iron and steel industry as a preferred industry, and provides substantial government direction for the growth and evolution of the industry. Specifically, in these plans, the provincial and local governments set detailed production and capacity targets for the region as well for individual companies. For example, Anhui Province’s 11th Five-Year Plan, covering the period 2006-2010, states that a “5 million ton sheet project will be built by Maanshan Iron & Steel Company” and that the same company “will reach 20 million tons in 2010.”⁵³ Similarly, the Hubei provincial government states that it will support “steel capacity expans[ion] ... to 22 million tons” by 2010.⁵⁴

⁴⁸ See The Tenth Five Year Plan for National Economic and Social Development of the People’s Republic of China, Gov’t of the PRC, available at http://www.gov.cn/english/official/2005-07/29/content_18334.htm.

⁴⁹ *Id.*

⁵⁰ 11th Five-Year Plan for National Economic and Social Development of the People’s Republic of China, Xinhuanet, available at http://news.xinhuanet.com/misc/2006-03/16/content_4309517_17.htm.

⁵¹ Russell Hsiao, *Major Reforms in the 12th Five-Year Plan?*, The Jamestown Foundation, June 24, 2010.

⁵² While the following analysis focuses primarily on provincial government policies, local government policies are similar in nature. For example, the Handan City 11th Five-Year Plan indicates that the city’s aim is to “strengthen the four pillar industries of steel, coal, electricity, and construction materials” and to “launch steel-based construction and upgrade the steel industry’s overall competitiveness.” See Handan City 11th Five-Year Plan, at 5, 41.

⁵³ Anhui Province 11th Five-Year Plan, at 5.

⁵⁴ Hubei Province 11th Five-Year Plan, at 11.

In addition, provincial governments use the five-year plans to manage product mix and direct certain companies and regions to focus on specific steel products. For instance, the Jiangxi provincial government has directed steel producers in the region to “extend plates and tubular products, develop plates for ships, for boiler furnaces, for pressure vessels, etc; develop high strength low alloy steel tube, replace solid drawn tube with welded tube, and develop welded steel tube for automobiles; and further develop plate spring and cold belt, eliminate hot rolled sheet, ordinary tubular steel, etc.”⁵⁵ Certain provincial governments even dictate the company that will produce a particular product. The Shandong provincial government, for example, has directed that “Jinan Steel company will develop sheet plate ... Laiwu Steel company will focus on the development and improvement of sectionals ... [and] Qingdao Steel company will put emphasis on wire with light sections.”⁵⁶

The provincial five-year plans further specify which technologies should be used in steel production,⁵⁷ and control the development of raw material output and transportation infrastructure to benefit the steel industry. Beijing’s provincial government has stated that it will “strictly limit and control the ore mine industry” for the benefit of the steel industry,⁵⁸ while another provincial government has pledged to “build more transportation facilities on the coast of northern China to meet demands for iron-ore imports of the steel companies located in north-east China and northern China.”⁵⁹

(iii) Law on State-owned Assets of Enterprises

In October 2008, China’s National People’s Congress passed the “Law on State-owned Assets of Enterprises” (“SOE law”) to allow further government control over SOEs.⁶⁰ As USTR recently reported, the objectives of this law are to “safeguard the basic economic system of China, consolidate and develop China’s state-owned enterprise assets, enable state-owned enterprises to play a dominant role in the national economy, especially in ‘key’ sectors, and promote [these objectives].”⁶¹ Further, the SOE law calls for improving the management system for state-owned assets, including with respect to “SASAC’s role, the rights and obligations of state-owned enterprises, corporate governance and major matters such as mergers, the issuance of bonds, enterprise restructuring and asset transfers.”⁶² In addition, the SOE law “stipulates that

⁵⁵ Jiangxi Province 10th Five-Year Plan, at 11.

⁵⁶ Shandong Province 10th Five-Year Plan, at 11.

⁵⁷ *See e.g.*, Inner Mongolia Autonomous Region 10th Five-Year Plan, at 5.

⁵⁸ Beijing Province 11th Five-Year Plan, at 45.

⁵⁹ Beijing Province 10th Five-Year Plan of Communication.

⁶⁰ USTR Report on WTO Compliance, at 60-61. The SOE law followed China’s establishment of the SASAC in 2003, which enhanced the government’s ability to intervene in the management and business decisions of SOEs. The SASAC was created to represent the state’s interest in the functioning of SOEs, including, among other things, taking daily charge of supervisory panels assigned to large SOEs, appointing and removing chief executives of SOEs, and supervising the preservation and appreciation of value of state-owned assets. *See id.*, at 60.

⁶¹ *Id.*, at 61.

⁶² *Id.*

the transfer of state assets to foreigners should follow relevant government policies and shall not harm national security or the public interest.”⁶³

Given that the steel industry is a “key” industry⁶⁴ that is substantially owned and controlled by the Chinese government, the SOE law provides yet another mechanism for the government to control the essential operations of most Chinese steel enterprises, from management to asset transfers.

(iv) List of Encouraged Industries

The central government’s “Catalogue of Key Industries, Products and Technologies the Development of Which is Encouraged by the State” (“Catalogue of Key Industries”) continues to list “Iron and Steel” as a preferred or favored industry along with dozens of specific steel products.⁶⁵ As a result of this classification, steel companies are eligible for various tax exemptions and reductions, including a 50 percent income tax reduction for companies that derive more than 70 percent of their revenues from manufacturing a product listed in the Catalogue of Key Industries. The catalogue also gives provincial and local authorities discretion to issue policies that help promote the development of these industries.

In 2005, the NDRC issued an updated list entitled the “Directory Catalogue on Readjustment of Industrial Structure.”⁶⁶ This list identifies 25 types of encouraged projects under the iron and steel category, and provides for certain benefits to the steel industry.

2. Restrictions on Foreign Investment

To further consolidate control over the steel industry and to protect its “national champions,” the Chinese government also heavily regulates foreign investment in the steel industry and imposes a number of other investment restrictions that appear to violate its WTO commitments. Most notably, China prohibits foreign companies from owning a controlling stake in Chinese steel producers. Specifically, Article 23 of China’s 2005 Steel Policy provides that “[f]or any foreign investment in the iron and steel industry of China, foreign investors are not allowed to have a controlling share.”⁶⁷ This restriction is further corroborated by USTR’s 2010

⁶³ *Id.*

⁶⁴ See State Council’s Guiding Opinions on Promoting the Adjustment of State-Owned Assets and the Restructuring of State-owned Enterprises, December 2006.

⁶⁵ See, e.g., Current Catalogue of Key Industries, Products and Technologies the Development of Which is Encouraged by the State, Foreign Affairs Information Portal, (Approved by the State Council on July 27, 2000), available at http://www.sdpc.gov.cn/zcfb/zcfbl/zcfbl2003pro/t20050708_28193.htm.

⁶⁶ Although the NDRC circulated a 2007 version of the “Directory Catalogue on Readjustment of Industrial Structure,” this list was circulated for comment only and the 2005 updated list remains in effect. See Directory Catalogue on Readjustment of Industrial Structure, NDRC Publication No. 40, December 2, 2005, available at http://www.fdi.gov.cn/pub/FDI_EN/Laws/law_en_info.jsp?docid=51119.

⁶⁷ Steel Policy, at Art. 23.

National Trade Estimate Report on Foreign Trade Barriers, which concludes that “foreign investors are not allowed to have a controlling share in steel and iron enterprises in China.”⁶⁸

Minority investments in the steel industry may also be rejected by the Chinese government and are subject to the approval of several governmental entities, including the Ministry of Commerce (“MOFCOM”), NDRC, SASAC (if the investment involves PRC’s state-owned assets), and the China Securities Regulatory Commission (if the investment involves a PRC listed company).⁶⁹ Although foreign companies are not prevented from investing in the Chinese steel industry *per se*, in practice, each authority can exercise its discretion to reject or withhold the approval of any foreign investment application. Moreover, the requirement (noted below) that foreign investors possess proprietary technology or intellectual property also appears to be used to restrict or prohibit minority investment, unless such investment is deemed advantageous by the government.

The Chinese government appears to be increasing its restrictions on foreign investment in the steel industry. In the most recent Foreign Investment Catalogue, steel has been downgraded from an “encouraged industry” with respect to foreign investment. As a result, foreign investors in the steel industry are no longer eligible for certain government benefits such as tax reductions and duty waivers.⁷⁰ Moreover, the NDRC’s 11th Five-Year Plan for foreign investment calls for more rigorous scrutiny of foreign investment.⁷¹ As USTR recently reported, this five-year plan “calls for the realization of a ‘fundamental shift’ from ‘quantity’ to ‘quality’ in foreign investment from 2006 to 2010, with the state’s focus changing from shoring up domestic capital and foreign exchange shortfalls to introducing advanced technology, management, expertise, and talent.”⁷² Further, “the plan seeks to restrict foreign enterprises’ acquisition of ‘dragon head’ enterprises, prevent the ‘emergence or expansion of foreign capital monopolies,’ protect national economic security, particularly ‘industry security,’ and prevent ‘abuse of intellectual property.’”⁷³ In short, fearing that certain foreign investments may be inconsistent with the

⁶⁸ See 2010 National Trade Estimate Report on Foreign Trade Barriers: China, U.S. Trade Representative, available at http://www.ustr.gov/sites/default/files/uploads/reports/2010/NTE/2010_NTE_China_final.pdf.

⁶⁹ In August 2006, new regulations on mergers and acquisitions were issued. These regulations strengthen MOFCOM’s supervisory role over foreign investment, in part by requiring MOFCOM’s approval for transactions that it believes will impact China’s economic security or involve famous Chinese brands. Specifically, Article 12 calls for MOFCOM’s approval of any deal involving a “major industry” having “impact on the state economic security” or concerning “famous trademarks or traditional Chinese brands” – a provision that appears to require MOFCOM approval on most foreign investment transactions. See *Communication from the United States, Transitional Review Mechanism Pursuant to Paragraph 18 of the Protocol on the Accession of the People’s Republic of China*, World Trade Organization, G/TRIMS/W/54, October 5, 2007.

⁷⁰ Catalogue for the Guidance of Foreign Investment Industries, December 1, 2007, available at http://www.fdi.gov.cn/pub/FDI_EN/Laws/law_en_info.jsp?docid=87372.

⁷¹ See *New Policy Stresses Quality of Foreign Investment*, November 10, 2006, available at <http://www.china.org.cn/english/BAT/188506.htm>.

⁷² USTR Report on WTO Compliance, at 66.

⁷³ *Id.*

central government's industrial policies and threaten its economic security, China has increased its scrutiny of foreign investments.⁷⁴

The Chinese government also restricts investment in the steel industry in a number of other ways that appear to violate its WTO obligations.⁷⁵ For example, China's steel policies require that foreign investors possess proprietary technology or intellectual property in the processing of steel.⁷⁶ According to USTR, "this requirement would seem to constitute a *de facto* technology transfer requirement, in conflict with the commitment in China's accession agreement not to condition investment on the transfer of technology."⁷⁷ USTR has also concluded that China's steel policies "appear[] to discriminate against foreign equipment and technology imports."⁷⁸ Specifically, the 2005 Steel Policy encourages the use of local content by calling for a variety of government subsidies for steel projects utilizing newly developed domestic equipment.⁷⁹ China's steel policies also call for the "use of domestically produced steel-manufacturing equipment and domestic technologies ... apparently in contravention of the commitment in China's accession agreement not to condition the right of investment or importation on whether competing domestic suppliers exist."⁸⁰

3. Raw Material Restrictions

The Chinese government's management and control of the steel industry extends to raw materials and other critical steel inputs. The Chinese government continues to intervene in raw material markets to ensure that its manufacturers have ready access to material inputs in quantities and at prices that give Chinese producers unfair market advantages. Among other policies, the government has implemented significant barriers to the export of raw materials from China, largely to ensure an abundant domestic supply at low prices. For example, China has enacted a number of WTO-inconsistent barriers to raw materials such as bauxite, coke, fluorspar, magnesium, silicon carbide, silicon metal, yellow phosphorus, and zinc.⁸¹ These export barriers include export quotas, export licensing requirements, and export taxes, each of which are being used in an increasingly restrictive manner. Indeed, the United States, the European Union and Mexico are currently challenging certain of China's export restraints on raw materials at the WTO. According to USTR:

⁷⁴ See *New Policy Stresses Quality of Foreign Investment*, November 10, 2006, available at <http://www.china.org.cn/english/BAT/188506.htm>.

⁷⁵ In paragraph 7.3 of its Protocol of Accession, China committed to comply with the TRIMs Agreement. China further agreed to "eliminate and cease to enforce trade and foreign exchange balancing requirements, local content and export or performance requirements made effective through laws, regulations or other measures."

⁷⁶ See *e.g.*, USTR Report on WTO Compliance, at 68-69.

⁷⁷ *Id.*, at 69.

⁷⁸ *Id.*

⁷⁹ *Id.*

⁸⁰ *Id.*

⁸¹ China – Measures Related to the Exportation of Various Raw Materials (DS394, DS395, DS 398), First Written Submission of the United States of America, at 1, June 1, 2010.

In the years since China's accession to the WTO in 2001, its export restraints have proliferated in number and kind, driven by the industrial policies adopted in the Five-Year Plans and other plans formulated and approved by China's central government. China now subjects over 600 items to non-automatic licensing and over 350 items to export duties. Moreover, these export restraints have become increasingly restrictive over time; export quota amounts have decreased steadily while export duty rates have increased steadily.⁸²

The overall effect of these restraints is to raise global raw material prices. At the same time, by increasing domestic supply of the raw materials, these measures depress domestic prices. In this way, the restraints provide steel producers in China with an artificial advantage in global steel markets.⁸³

For example, China's export restrictions on coke, a critical steel input, have had a measurable effect on world coke supplies and prices. In November 2006, China imposed a 5 percent export tax on coke (along with the existing quota).⁸⁴ In January 2007, shortly after the new tax took effect, Chinese domestic and export prices for coke were almost exactly the same, at \$150.63/metric ton ("MT") and \$150.29/MT, respectively. Over the course of 2007 and 2008, the Chinese government increased the export tax on coke, first to 15 percent, then to 25 percent, and finally to 40 percent.⁸⁵ By the end of 2008, Chinese domestic coke prices were \$184.88/MT, while export prices were \$554.62/MT. The following chart shows the enormous gap that opened between domestic and export prices following the imposition of the export tax in 2006.

⁸² *Id.*

⁸³ See Dr. Gene Grossman and Dr. Mark Watson, *Critique of China's Economic Analysis of the Export Restraints on Several Raw Materials*, attached as Exhibit JE-158, China – Measures Related to the Exportation of Various Raw Materials (DS394, DS395, DS398), Second Written Submission of the United States.

⁸⁴ Z. Sun and X. Xum, *Empirical study on Chinese Coke Export Market Power*, 2 *Journal of Chinese Economic and Foreign Trade Studies*, at 137, 2009.

⁸⁵ *Id.*

CHART 2

Chinese Coke: Domestic and Export Prices

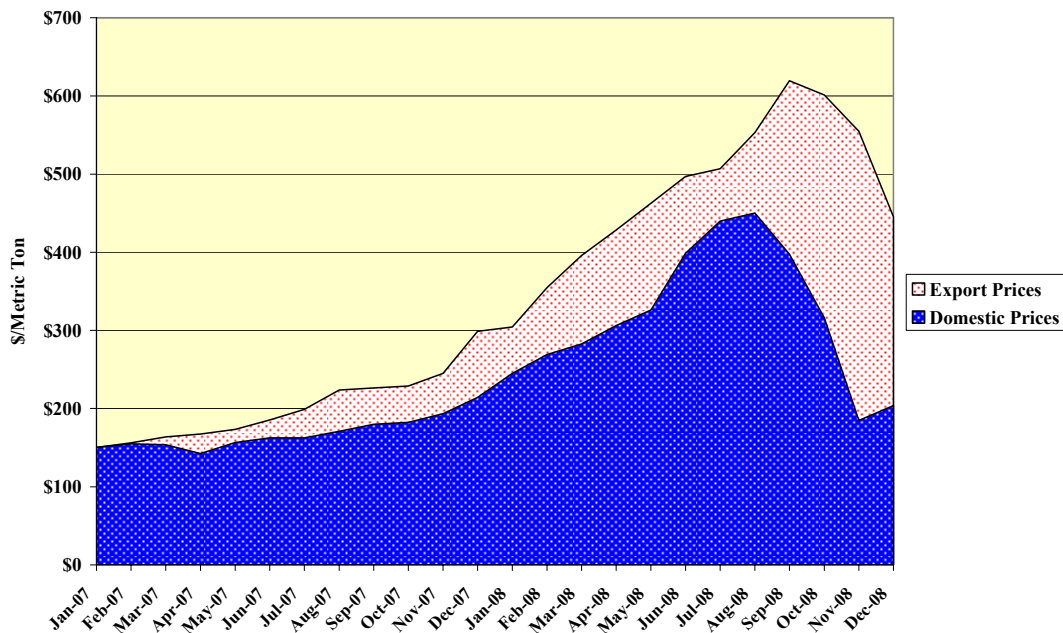

Sources: Metal Expert News for Domestic Prices and Global Trade Atlas for Export Prices.

In December 2008, domestic Chinese prices for coke were \$241/MT lower than export prices. Production of one ton of steel requires approximately 0.6 tons of coke.⁸⁶ This means that Chinese steel producers enjoyed a cost advantage of nearly \$145/MT over their international competitors. MEPS, a leading source of steel industry statistics, calculated a “global composite carbon steel price” for December 2008 of \$676/MT. Because of China’s export restraints, Chinese steel producers enjoyed a cost advantage equal to more than 20 percent of the world market price for carbon steel. A similar gap between domestic and export prices, and the resulting benefits to Chinese steel producers, continues to exist today.⁸⁷

Despite the Chinese government’s efforts to justify their export barriers (*i.e.*, for environmental purposes), these restrictions are little more than a thinly veiled attempt at industrial planning – to artificially advantage China’s domestic manufacturers with greater quantities of cheap raw material inputs and bolster downstream exporting industries. Indeed, many of these measures have been implemented to create a disparity between domestic prices and world market prices – a disparity that favors China’s domestic enterprises.

As a result, Chinese producers and other manufacturers are receiving an unfair advantage, making them more cost-competitive and profitable than they would otherwise be in an open market. China’s interference in raw material markets has also adversely impacted the availability and price of critical raw materials worldwide. The result is a significant and unfair advantage for Chinese domestic manufacturers and increased input costs for manufacturers in

⁸⁶ *Coal & Steel Facts*, World Coal Institute, 2008.

⁸⁷ See Metal Expert Group (data downloaded October 6, 2010).

other markets, including the United States. As USTR has concluded: “China’s export restraints not only distort world markets in these critical Raw Materials but they also have effects through the entire manufacturing chain and broad implications for competition and trade in a variety of products.”⁸⁸

C. Conclusion

In sum, through its ownership stakes and numerous industrial policies, the Chinese government continues to exercise significant control over the growth and evolution of the steel industry, including with respect to raw materials. Despite its commitments regarding market reforms, government intervention in the steel industry has grown steadily since China’s accession to the WTO in 2001. Indeed, the Chinese government has shown no signs of relinquishing control over the steel industry, as China’s large steel-producing SOEs are now being deployed overseas to further the government’s political objectives.

IV. THE ACCELERATION OF CHINA’S GOING ABROAD STRATEGY

The next step in China’s government-directed industrial strategy is expansion abroad – a strategy which the government is now actively implementing. First announced by the government in 1999, China’s Going Abroad⁸⁹ strategy is a government-mandated policy intended to strengthen the presence of Chinese companies abroad. Specifically, the Going Abroad strategy directs Chinese enterprises, particularly large SOEs, to invest abroad and establish “greenfield” operations overseas. In essence, after creating, developing, and nurturing massive “national champions,” the Chinese government is now strategically deploying these entities overseas to execute the government’s agenda: to acquire natural resources and raw materials, obtain technology and expertise, gain entry into new markets, and increase China’s economic and political influence on a global scale.

A. China’s Going Abroad Policy Framework

China’s Going Abroad policy is mandated by government industrial policies at both the central and provincial levels – again, in violation of China’s WTO commitments to refrain from influencing the decisions of its SOEs and to permit SOEs to operate based solely on commercial considerations. Many of these policies identify which entities are to go abroad, and call for government subsidies and other support to enable these entities to do so. The most recent policies require that the implementation of the Going Abroad strategy be accelerated. Indeed, as Chinese Premier Wen Jiabo announced last year, China intends to “hasten the implementation of [the] ‘going out’ strategy.”⁹⁰

⁸⁸ China – Measures Related to the Exportation of Various Raw Materials (DS394, DS395, DS 398), First Written Submission of the United States of America, at 2, June 1, 2010.

⁸⁹ This strategy has also been referred to as China’s “Going Out” Strategy, “Go Out” Strategy, and “Go Abroad” Strategy.

⁹⁰ *China to Spend Reserves to Grow Overseas*, UPI.com, July 21, 2009, available at http://www.upi.com/Business_News/2009/07/21/China-to-spend-reserves-to-grow-overseas/UPI-77231248220167/.

1. 2009 Steel Adjustment and Revitalization Plan

The 2009 Revitalization Plan mandates that Chinese steel producers invest abroad. Indeed, one of the “Basic Principles” set forth in the Revitalization Plan is to “grasp the opportunities to implement the strategy of ‘Going out to the Outside World.’”⁹¹ In accordance with this principle, the Revitalization Plan provides for extensive financial and other government support for Chinese steel enterprises to “go to the outside world” for “exploration, development, technical cooperation, and mergers and acquisitions” abroad. For example, the plan:

- encourages Chinese steel enterprises “to make exclusive investments or set up joint ventures abroad”⁹² and encourages “qualified backbone enterprises . . . to carry out resource exploration, development, technical cooperation and mergers and acquisitions . . . overseas;”⁹³
- calls for the simplification of policies and procedures to facilitate going abroad. Specifically, the Revitalization Plan states that the “procedures for examination and approval of projects shall be further simplified” and that the “policies and measures for credit, foreign exchange, finance and taxation, and entry and exit of personnel” shall be improved;⁹⁴ and
- dictates that “the operating management for overseas assets should be further enhanced, so as to avoid asset risk from abroad,” the “size of export credit for metallurgical equipment shall be enlarged to drive the export of equipment and materials,” and the “export credit insurance policy shall be improved to support steel enterprises to set up overseas marketing networks and stabilize the export of high end products.”⁹⁵

To achieve these objectives, the Revitalization Plan mandates financial assistance for China’s “backbone steel enterprises” (*i.e.*, China’s large SOEs) to go abroad.⁹⁶ The plan states that “projects which . . . go to the outside world and make technological progress” shall be supported through the government’s issuance of “stocks, corporate bonds, middle-term bills, short term financing and bank loans” and the absorption of privately collected equity.⁹⁷ Further, “loan discounts shall be available.”⁹⁸ In addition, the Revitalization Plan emphasizes the need to “take full advantage of the special funds from overseas mineral resources investment, foreign

⁹¹ See Gov’t of the PRC Steel Adjustment and Revitalization Plan, March 23, 2009.

⁹² *Id.*

⁹³ *Id.*

⁹⁴ *Id.*

⁹⁵ *Id.*

⁹⁶ *Id.*

⁹⁷ *Id.*

⁹⁸ *Id.*

economic and technical cooperation and overseas mineral resources exploration, so as to support enterprises to implement the strategy of ‘going to the outside world.’”⁹⁹

2. June 2010 State Council Policy

The June 2010 State Council Policy calls for the promotion of the Going Abroad strategy through a wide-range of government measures.¹⁰⁰ These measures include supporting the use of “two markets” by Chinese steel enterprises, creating large backbone enterprises capable of competing abroad, increasing investments abroad, and deepening economic and technological cooperation overseas. Specifically, the State Council Policy mandates government support for accelerating the Going Abroad strategy, including for “strengthening overseas investment and transnational operations,” “construct[ing] iron and steel factories and industrial parks abroad,” and “improv[ing] the level of iron and steel enterprises’ international management.”¹⁰¹

To ensure a steady supply of iron ore for domestic steel production, moreover, the State Council Policy also encourages steel enterprises to develop iron ore exploration and exploitation abroad, and to consider the construction of mining fields, roads, ports, power supplies, and water supply facilities.

3. Five-Year Plans

Central Government Five-Year Plans: The mandate to “go abroad” is also a central focus of China’s recent five-year plans. The 10th Five-Year Plan for National Economic and Social Development, covering the period 2000-2005, called for the development of the Going Abroad strategy as well as for measures to promote overseas investment and encourage the exploration of resources abroad. The 11th Five-Year Plan, covering the 2006-2010 period, calls for an acceleration of the Going Abroad strategy. The plan calls for the “nurture” and “support” of the overseas business operations of China’s capable enterprises, including their direct investment in foreign countries.¹⁰² It provides for “enterprises to develop overseas” through “transnational mergers and acquisitions,” enhancing “cooperation in exploring and exploiting overseas resources,” and “encourag[ing] enterprises to participate in the construction of overseas infrastructure.”¹⁰³ The plan also calls for the implementation of mechanisms to promote overseas investments and to “monitor[] overseas state-owned assets.”¹⁰⁴

Provincial Government Five-Year Plans: China’s provincial governments have also called for the acceleration of the Going Abroad strategy through their five-year plans, and for the provision of financial assistance to enable SOEs and other large steel enterprises to go abroad. For example:

⁹⁹ *Id.*

¹⁰⁰ State Council Policy at VII(15).

¹⁰¹ *Id.* at VIII(15).

¹⁰² See 11th Five-Year Plan for National Economic & Social Development of the People’s Republic of China, available at http://news.xinhuanet.com/misc/2006-03/16/content_4309517_17.htm.

¹⁰³ *Id.*

¹⁰⁴ *Id.*

- A primary focus of Hubei Province’s 11th Five-Year Plan is “[a]ccelerating” the implementation of the Going Abroad strategy.¹⁰⁵ The Hubei government’s plan calls for Chinese enterprises to invest, build factories, and exploit resources overseas as well as improve the quality and benefits of external trade.
- The 11th Five-Year Plan for Jiangsu Province also specifically calls for the “accelerat[ion] of the Going Abroad strategy.”¹⁰⁶ The plan encourages capable industries to invest abroad, establish overseas production facilities, and target surrounding and developing countries.
- Liaoning Province’s 11th Five-Year Plan states that the “quality and level of ‘opening to the outside world’ must improve.”¹⁰⁷ The plan reinforces the importance of perfecting policy and service systems for overseas investment. It also encourages capable enterprises to invest and build factories abroad, establish corporate branches overseas, and conduct company mergers and consolidations.
- Shanghai City’s 11th Five-Year Plan calls for “*reinforce[ment]*” of the Going Abroad strategy.¹⁰⁸ The plan directs capable enterprises with comparative advantages to invest abroad in the exploration and exploitation of natural resources and energy; merge with and acquire foreign enterprises that have advanced technologies, brands, and sales networks; undertake overseas projects and export labor; and accelerate the cultivation of China’s transnational corporations.

In addition to calling for the aggressive implementation of the Going Abroad strategy, certain provincial five-year plans also specify the foreign countries that Chinese enterprises should target in their overseas investments. For example, Shandong Province’s 11th Five-Year Plan states that enterprises must “*vigorously*” implement the Going Abroad strategy¹⁰⁹ and further encourages “[l]argely expand[ing] ... in developing countries in Africa, Latin America, Middle East, South Asia, and Eastern Europe.”¹¹⁰ The plan also encourages enterprises to “strive to have major break-throughs in market expansion in developed countries in Europe and the U.S.”¹¹¹

B. Going Abroad Pursuant to Government Policies

In accordance with these government policies, China’s enterprises are investing abroad at unprecedented rates, confirming what the Chinese Communist Party has already acknowledged –

¹⁰⁵ Hubei Province Five-Year Plan, at 2.

¹⁰⁶ Jiangsu Province Five-Year Plan, at 3.

¹⁰⁷ Liaoning Province Five-Year Plan.

¹⁰⁸ Shanghai City Five-Year Plan, at 5 (emphasis added).

¹⁰⁹ Shandong Province Five-Year Plan (emphasis added).

¹¹⁰ *Id.*

¹¹¹ *Id.*

“the pace of Chinese enterprises ‘going global’ has been noticeably accelerated.”¹¹² According to MOFCOM, China invested \$43.3 billion overseas in 2009, which is almost twenty times more than the average \$2.4 billion per year that China invested abroad between 1990 and 2000.¹¹³ Moreover, though MOFCOM has yet to release its actual overseas investment figures for 2010, the agency reported recently that China’s global overseas investment was already \$55.2 billion at the end of June 2010.¹¹⁴ While these figures are impressive, the Organization for Economic Cooperation and Development (“OECD”) and other authorities have suggested that such figures substantially underestimate China’s overseas investments.¹¹⁵ Furthermore, these increases come at a time when global outbound direct investment has slumped due to the economic recession.¹¹⁶

Reports also indicate that the number of Chinese outbound merger and acquisition (“M&A”) deals have reached unprecedented levels. In the first half of 2010 alone, Chinese outbound M&A deals increased by “more than 50 percent over the same period last year.”¹¹⁷ During the first six months of 2010, “99 outbound deals were announced,” 14 of which involved foreign natural resources.¹¹⁸

Much of China’s outbound investment is targeted at the United States. Indeed, recent investment statistics reveal that China’s “great outward march of investing into the United States is turning into a mad dash.”¹¹⁹ Chinese investments into the United States jumped 360 percent in the first half of 2010 compared to the same period last year, according to Chinese government figures.¹²⁰ In 2009, Chinese enterprises announced new direct investment in the United States of approximately \$5 billion, up from \$500 million in 2008, and despite a significant global downturn in such investments.¹²¹ Moreover, Chinese firms acquired or announced that they were starting more than 50 U.S. companies in 2009.¹²² The following table identifies a number of recent Chinese investments into the United States, the vast majority of which were by Chinese SOEs.¹²³

¹¹² “Going Abroad” and How to Make it Happen, People’s Daily Online, April 17, 2009, available at <http://english.peopledaily.com.cn/90001/90780/91344/6639594.html>.

¹¹³ Michael J. Enright, W. John Hoffmann, and Peter Wood, *Get Ready, Here China Inc. Comes*, The Wall Street Journal On-Line, February 24, 2010.

¹¹⁴ Sheridan Prasso, *The United States...of China?*, Fortune, July 21, 2010.

¹¹⁵ Michael J. Enright, W. John Hoffmann, and Peter Wood, *Get Ready, Here China Inc. Comes*, The Wall Street Journal On-Line, February 24, 2010.

¹¹⁶ *Made in the U.S.A., Financed by China Nation Increasing Global Investments*, The Star-Ledger, March 7, 2010.

¹¹⁷ Hu Yuanyuan, *China-related M&As to Rebound*, China Daily Online, August 17, 2010.

¹¹⁸ *Id.*

¹¹⁹ Sheridan Prasso, *The United States...of China?*, Fortune, July 21, 2010.

¹²⁰ *Id.*

¹²¹ *Id.*

¹²² Sheridan Prasso, *American Made ... Chinese Owned*, Fortune, May 24, 2010.

¹²³ *Made in the U.S.A., Financed by China Nation Increasing Global Investments*, The Star-Ledger, March 7, 2010.

TABLE 2¹²⁴

Chinese Outward Investment 2007-2009 – United States (Investments and Contracts)

Year	Investor	Quantity in millions	Partner	Sector	Subsector	Country
2007-02	Sinopec	\$ 100	Syntroleum	Energy	Coal	USA
2007-05	CIC	\$ 3,100	Blackstone	Finance	Investment	USA
2007-10	Minsheng Bank	\$ 200	UCBH	Finance	Banking	USA
2007-12	CIC	\$ 5,000	Morgan Stanley	Finance	Investment	USA
2008-01	Wuxi PharmaTech	\$ 150	AppTec Lab Services	Technology	Biomedical	USA
2008-03	CIC	\$ 100	Visa	Finance		USA
2008-03	China Life	\$ 260	Visa	Finance		USA
2008-04	CIC	\$ 3,200	JC Flowers	Finance	Investment	USA
2008-06	China National Cereals, Oils and Foodstuffs	\$ 140	Smithfield Foods	Agriculture		USA
2008-06	SAFE	\$ 2,500	TPG	Finance	Investment	USA
2008-10	CIC	\$ 200	Blackstone	Finance	Investment	USA
2009-03	CIC	\$ 800	Morgan Stanley	Real Estate	Property	USA
2009-06	CIC	\$ 500	Blackstone	Finance	Investment	USA
2009-06	CIC	\$ 530	Blackrock	Finance	Investment	USA
2009-06	CIC	\$ 1,210	Morgan Stanley	Finance	Banking	USA
2009-09	CIC	\$ 600	Oaktree Capital Management	Finance	Investment	USA
2009-09	CIC	\$ 600	Goldman Sachs	Finance	Investment	USA
2009-11	Beijing West Industries	\$ 100	Delphi	Transport	Autos	USA
2009-11	State Construction Engineering	\$ 100		Transport	Rail	USA
2009-11	CIC	\$ 1,580	AES	Power		USA
2009-12	Jinjiang International Hotels	\$ 150	Thayer Lodging	Real Estate	Tourism	USA
2009-12	BAIC	\$ 200	Saab	Transport	Autos	USA

© Data compiled by The Heritage Foundation.

As described below, while many of China’s initial overseas ventures involved securing access to raw materials, China is now also targeting downstream industries such as steel.

1. Securing Access to Raw Materials

In response to China’s rapidly increasing demand for raw materials, the Chinese government has been systematically deploying entities abroad to secure access to raw materials. The global steel industry is dependent upon a number of basic raw materials, including iron ore, scrap, coke, and various alloying elements. While some materials, such as iron ore and scrap, are relatively widely distributed, others are limited to a few suppliers. However, even the international trade in materials that are widely distributed, such as iron ore, is dominated by only

¹²⁴ Derek Scissors, *China Global Investment Tracker: 2010*, Heritage Foundation, February 22, 2010, available at <http://www.heritage.org/research/reports/2010/02/china%20global%20investment%20tracker%202010>.

a handful of countries. In an effort to ensure reliable sources of supplies for the Chinese steel industry and other manufacturing sectors, the Chinese government has coordinated and funded efforts by Chinese enterprises to acquire these raw materials overseas.

In 2009 alone, companies based in China “participated in \$13 billion of outbound mining acquisitions and investments last year – 100 times the level in 2005.”¹²⁵ While China accounted for 1 percent of the value of all cross border mining M&A deals in 2004 and 7.4 percent in 2007, China accounted for one-third of all deals in 2009.¹²⁶ Some recent examples include the following:

- In 2008, the Aluminum Company of China, also referred to as Chinalco, purchased a 9.3 percent stake in the Australian mining company Rio Tinto.¹²⁷
- In 2008, the China Metallurgical Group Corporation bid \$3.4 billion for the rights to mine copper reserves near Aynak, Afghanistan. According to *The New York Times*, this investment “underscores how China’s leaders, flush with money and in control of both the government and major industries, meld strategy, business and statecraft into a seamless whole. In a single move, Beijing strengthened its hold on a vital resource, engineered the single largest investment in Afghan history, promised to create thousands of new Afghan jobs and established itself as the Afghan government’s pre-eminent business partner and single largest source of tax payments.”¹²⁸
- In February 2009, Hunan Valin, a steel-producing SOE, signed an agreement to acquire a 16.5 percent stake in Fortescue Metals Group, an Australian mining company.¹²⁹
- In July 2009, Minmetals completed a “\$1.7 billion takeover of Oz Metals with the formation of its new Australian-based company Minerals and Metals Group.”¹³⁰
- In March 2010, the East China Mineral Exploration and Development Bureau agreed to pay 1.2 billion dollars to acquire Brazilian iron ore miner Itambas Comercio de Minerios.¹³¹

¹²⁵ Phred Dvorak, *Chinese Firms Snap Up Mining Assets*, The Wall Street Journal Online, July 20, 2010.

¹²⁶ *Id.*

¹²⁷ *Uneasy Engagement: Australia Nourishing China’s Economic Engine, Questions Ties*, The New York Times, June 3, 2009, available at <http://www.nytimes.com/2009/06/03/world/asia/03australia.html>.

¹²⁸ *Uneasy Engagement: China Willing to Spend Big on Afghan Commerce*, The New York Times, December 30, 2009, available at <http://www.nytimes.com/2009/12/30/world/asia/30mine.html?partner=rss&emc=rss>.

¹²⁹ Kim Hunter Gordon, *Hunan Valin Buys 16.5 Percent Stake in Fortescue Metals*, Proactive Investors, February 25, 2009, available at <http://www.proactiveinvestors.com.au/companies/news/907/hunan-valin-buys-16.5-percent-stake-in-fortescue-metals-0907.html>.

¹³⁰ Greg Ansley, *Business with Beijing as Usual Despite Spy Arrests*, NZ Herald News, July 15, 2009, available at http://www.nzherald.co.nz/rio-tinto-limited/news/article.cfm?o_id=177&objectid=10584477.

- On March 19, 2010, Rio Tinto and Chinalco signed a Memorandum of Understanding to “establish a joint venture covering the development and operation of the Simandou iron ore project.”¹³² According to Rio Tinto, “[o]nce fully operational, the mine is expected to produce over 70 million tonnes of iron ore per annum.”¹³³
- In April 2010, Honbridge Holdings, a Chinese investment group, purchased Sul Americana Metais, an iron ore mining firm in Minas Gerais, Brazil, from a Brazilian company for \$390 million. It was reported that “[i]ncluded in the deal is one mine with an estimated capacity of 2.8 billion [tons], representing a forecast extraction of 25 million tons per year for the next 20 years.”¹³⁴
- In July 2010, China’s third largest steel producer, Wuhan Iron and Steel Corp., “announced a joint venture deal with Centrex Metals Ltd., an Australian-based miner, to explore iron ore mines on South Australia’s Eyre Peninsula.”¹³⁵
- On July 13, 2010, African Minerals, an iron-ore and base-metals miner, announced that it had “entered into a \$1.5-billion strategic investment understanding with Chinese steel company Shandong Iron & Steel Group to fund its flagship iron-ore Tonkolili project in Sierra Leone.”¹³⁶ In exchange for funding, African Minerals agreed to provide Shandong a long-term supply of iron ore and a 25 percent stake in the West African project.¹³⁷

As these examples confirm, Chinese companies are closing more sophisticated deals and at higher rates of success in their global quest for raw materials.¹³⁸ Given the frenzied pace at which China is pursuing these investments, some commentators predict that “China’s hunger for metals and minerals will be a principal driver in boosting its overall outbound investment to more than \$100 billion in 2014.”¹³⁹

¹³¹ *FACTBOX-China’s Surging Direct Investment in Brazil*, Reuters, August 10, 2010, available at <http://af.reuters.com/article/energyOilNews/idAFN0517861620100810>.

¹³² *Rio Tinto and Chinalco Sign Memorandum of Understanding to Form Iron Ore Joint Venture for the Simandou Project in Guinea*, RioTinto, March 19, 2010, available at http://www.riotinto.com/media/18435_media_releases_19083.asp.

¹³³ *Id.*

¹³⁴ *Honbridge Buys Exploratory Mining Outfit in Brazil for US\$390 Million*, The China Post, April 22, 2010, available at <http://www.chinapost.com.tw/business/company-focus/2010/04/22/253594/Honbridge-buys.htm>.

¹³⁵ *WISCO Eyes Iron Ore Exploration in Australia*, China Knowledge, July 13, 2010, available at http://www.chinaknowledge.com/Newsires/News_Detail.aspx?type=1&cat=CMP&NewsID=%2035278.

¹³⁶ Loni Prinsloo, *Chinese to Invest \$1.5bn in West African Iron-ore Project*, MiningWeekly.com, July 13, 2010, available at <http://www.miningweekly.com/article/chinese-to-invest-15bn-in-west-african-iron-ore-project-2010-07-13>.

¹³⁷ *Id.*

¹³⁸ *Id.*

¹³⁹ Phred Dvorak, *Chinese Firms Snap Up Mining Assets*, The Wall Street Journal Online, July 20, 2010.

2. SOE Investment in the U.S. Steel Industry – The Anshan Example

In addition to raw materials, the Chinese government is beginning to deploy its national champions overseas to invest in downstream industries such as steel. The Anshan Iron and Steel Group¹⁴⁰ (“Anshan”), for example, is one of the many Chinese SOEs being directed to invest abroad by the Chinese government. On May 17, 2010, Anshan announced that it was forming a joint venture with the Steel Development Co. (“SDC”) of Amory, Mississippi to build up to five new steel plants in the United States.

Anshan’s investment in SDC is the direct result of China’s industrial policies. As an initial matter, like the vast majority of China’s steel industry, Anshan is the direct product of the Chinese government. It is an SOE – 100 percent owned and controlled by the Chinese government – and has become China’s fourth largest steel producer through government-mandated mergers and the receipt of massive government subsidies. Indeed, as detailed above, the creation of massive steel-producing SOEs, and their deployment abroad, is required by China’s industrial policies. China’s 2009 Revitalization Plan and other steel policies explicitly mandate the reorganization of Anshan through mergers and acquisitions – a requirement with which it has duly complied. The Revitalization Plan also explicitly identifies Anshan as a recipient of extensive government support in order to strengthen its international competitiveness and to assist Anshan in acquiring strategic resources and establishing operations abroad. Consistent with this government mandate, Anshan is now investing in the U.S. steel market, with the full force and encouragement of the Chinese government.

Anshan itself has made clear that its investment decision is part of the government’s Going Abroad strategy. Anshan stated that, in making the investment, it is fulfilling its “sacred mission” as the “eldest son” of the Chinese steel industry to extend the reach of that industry abroad. Specifically, Anshan explained that:

Anshan’s investment in building mills in the U.S. is not only going to fit the need of self-development, it is also Anshan’s sacred mission of being the ‘eldest son of iron and steel’ of the world’s largest iron and steel country. It will demonstrate China’s iron and steel industry’s capabilities in international deployment and operations, and their influences on the industry. It is also Anshan’s contribution to the realization of transforming China from a big iron and steel country to a strong iron and steel country.¹⁴¹

Moreover, several of Anshan’s justifications for its investment derive directly from the above-referenced industrial policies, including acquiring advanced technology and returning the technology to China, and “enhanc[ing] the internationalization of Anshan.”¹⁴² The company has

¹⁴⁰ Anshan Iron and Steel Group is part of the Anben Iron and Steel Group. *See Appendix 1.*

¹⁴¹ *Angang to Invest and Build Factory in the United States*, Anshan Iron and Steel Group Corporation, May 17, 2010, available at <http://www.ansteelgroup.com/news/xwzx/2010-05-17/782.html> (Chinese version).

¹⁴² *Id.*

also justified its investment in SDC as a means to avoid paying antidumping duties and to profit from the U.S. stimulus bill.¹⁴³

3. Implications for the United States

The U.S. steel industry is no stranger to foreign investment. In fact, a number of major privately owned foreign steel producers have facilities in the United States. A critical distinction exists, however, between foreign investment directed by private companies to further commercial considerations, and foreign investment pursued by government-controlled entities to advance political objectives. While the former category of foreign investment has and should continue to play an important role in the growth and development of the U.S. economy, the latter category may threaten the economic security of the United States. As detailed below, the Anshan investment is a prime example of the concerns faced by the United States and other countries as a result of China's pursuit of government-mandated industrial policies.

As an SOE, Anshan operates at the direction of the Chinese government and for the purpose of advancing government aims. As such, Anshan operates in an environment where basic market forces can be ignored to achieve government objectives. Moreover, because it receives massive government support, Anshan can obtain cash grants, subsidized financing and other support from the Chinese government, even in the worst economic conditions. As a result, Anshan has significantly less incentive to make production, pricing, or any other business decisions based on market principles. As Lawrence Summers, currently the Director of the White House National Economic Council, noted several years ago with respect to Chinese outbound investment:

What has received less attention are the particular risks associated with ownership by government-controlled entities, particularly where the ownership stake is taken through direct investments. The logic of the capitalist system depends on shareholders causing companies to act so as to maximize the value of their shares. It is far from obvious that this will over time be the only motivation of governments as shareholders. They may want to see their national companies compete effectively, or to extract technology or to achieve influence.¹⁴⁴

The U.S. Securities and Exchange Commission ("SEC") has also raised a number of concerns with respect to foreign government investment in the U.S. economy, including issues of market efficiency, transparency, enforcement, political corruption, and information disparity.¹⁴⁵

¹⁴³ James T. Areddy, *Anshan to Invest in the U.S.*, The Wall Street Journal Online, May 18, 2010; *Anshan Iron and Steel Plant in the U.S.*, Ministry of Anshan Iron and Steel Group Company, May 17, 2010, (Chinese translated version).

¹⁴⁴ Lawrence Summers, *Funds that Shake Capitalist Logic*, Financial Times, July 29, 2007.

¹⁴⁵ Chairman Christopher Cox, *The Rise of Sovereign Business*, SEC Chairman Speech, December 5, 2007, available at <http://www.sec.gov/news/speech/2007/spch120507cc.htm>; Ethiopis Tafara, *Testimony Concerning Foreign Government Investment in the U.S. Economy and Financial Sector*, March 5, 2008, available at <http://www.sec.gov/news/testimony/2008/ts030508et.htm>.

In short, this type of investment forces private steel companies to compete directly against the Chinese government in the U.S. marketplace, creating significant imbalances that harm private companies and distort the steel market. Such market distortions are the very reason that the U.S. government and the OECD have worked for years to remove government ownership and subsidies from the steel industry – an effort that is being severely undermined by these types of investments.

Investments like the Anshan investment also raise national security concerns. The U.S. steel sector plays a critical role in our national defense, and in building and maintaining the nation’s critical infrastructure. The Anshan transaction could provide the Chinese government with direct access to, and information concerning, current and future U.S. infrastructure, energy and defense projects that may be critical to national defense. Moreover, as Anshan itself has acknowledged, the investment could provide the Chinese government with potential new technologies in the steel production industry.

The Anshan investment and the increasing number of similar Chinese government intrusions into the U.S. market raise the question of whether it is appropriate for foreign governments to compete in the U.S. market against private companies, especially where the government involved restricts investments into its own market and may have objectives at odds with U.S. national interests. While the United States does and should continue to welcome foreign investment, foreign government involvement in the U.S. market raises unique economic and security concerns.

V. CONCLUSION

The Chinese steel industry in its current form is the creation of the Chinese government. Chinese steel producers continue to benefit from massive direct and indirect subsidies, many of which violate China’s WTO commitments. Moreover, despite its WTO obligations regarding market reforms, the Chinese government continues to increase its ownership and control of the steel industry, allowing the government to direct virtually all aspects of the industry. Indeed, China’s unprecedented growth in steel production has little to do with market forces, but has been the result of the Chinese government’s pervasive ownership and control of the industry. Despite China’s claims that it is progressing toward a more market-based economy, nothing could be further from the truth with respect to the government’s ownership and control of the steel industry.

These policies and actions by the Chinese government have distorted world trade and have imposed tremendous economic costs on other countries, including the United States. By making its steel industry artificially competitive in world markets, the Chinese government has disadvantaged market-oriented producers around the globe, including those in the United States. Deploying its steel-producing SOEs overseas to compete in private markets will only further distort global steel markets and cause additional harm to U.S. steel companies and their workers. Despite its WTO commitments, the Chinese government has chosen to increase its ownership, and control of its steel industry. As a result, the United States and other trading partners should increase efforts to ensure China’s compliance with its WTO commitments and international legal obligations.

APPENDIX 1

OWNERSHIP FLOW CHARTS FOR CHINA'S
TOP FOUR STEEL PRODUCERS

1. Hebei Iron & Steel Group

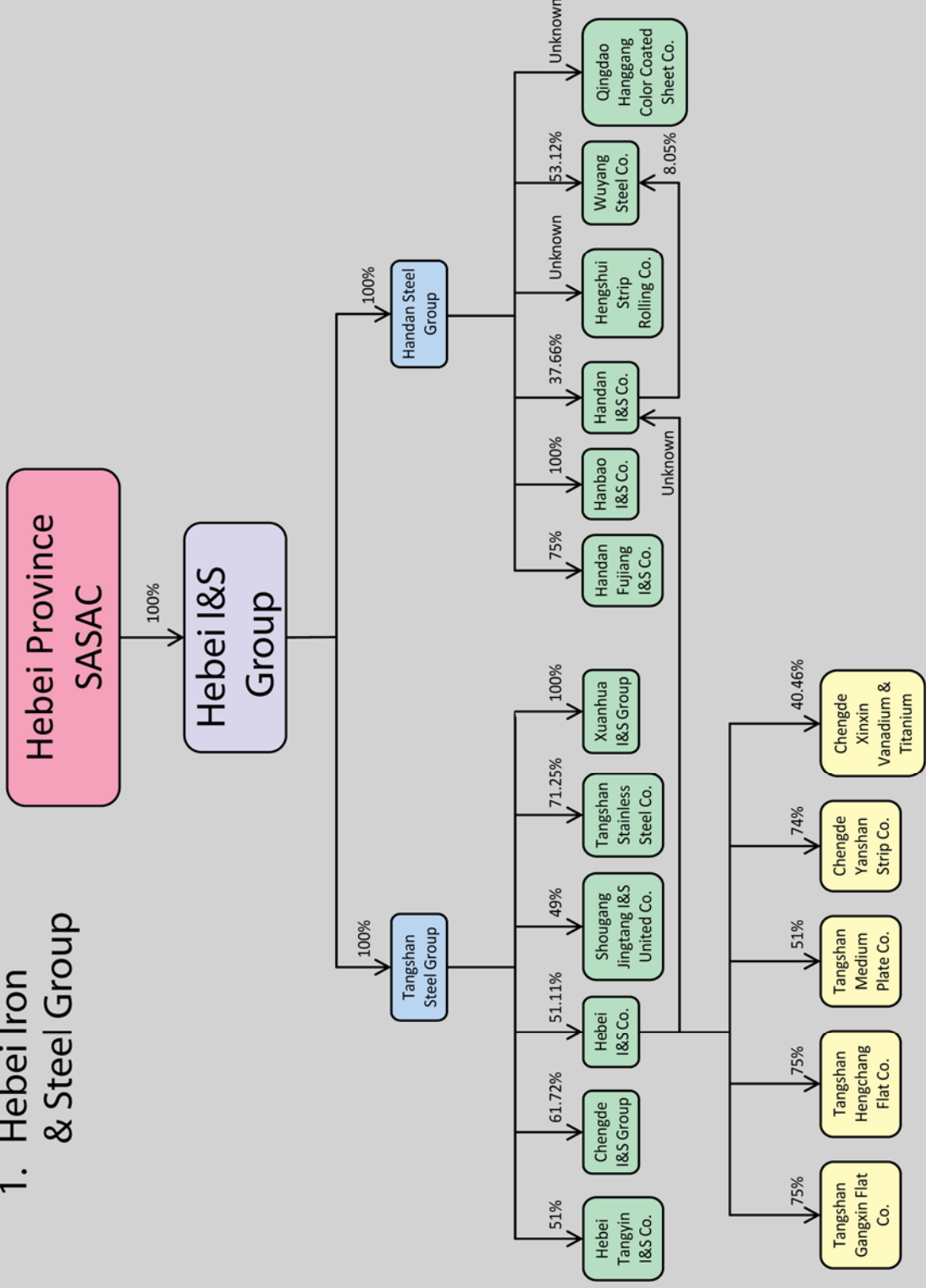

2. Baosteel Group

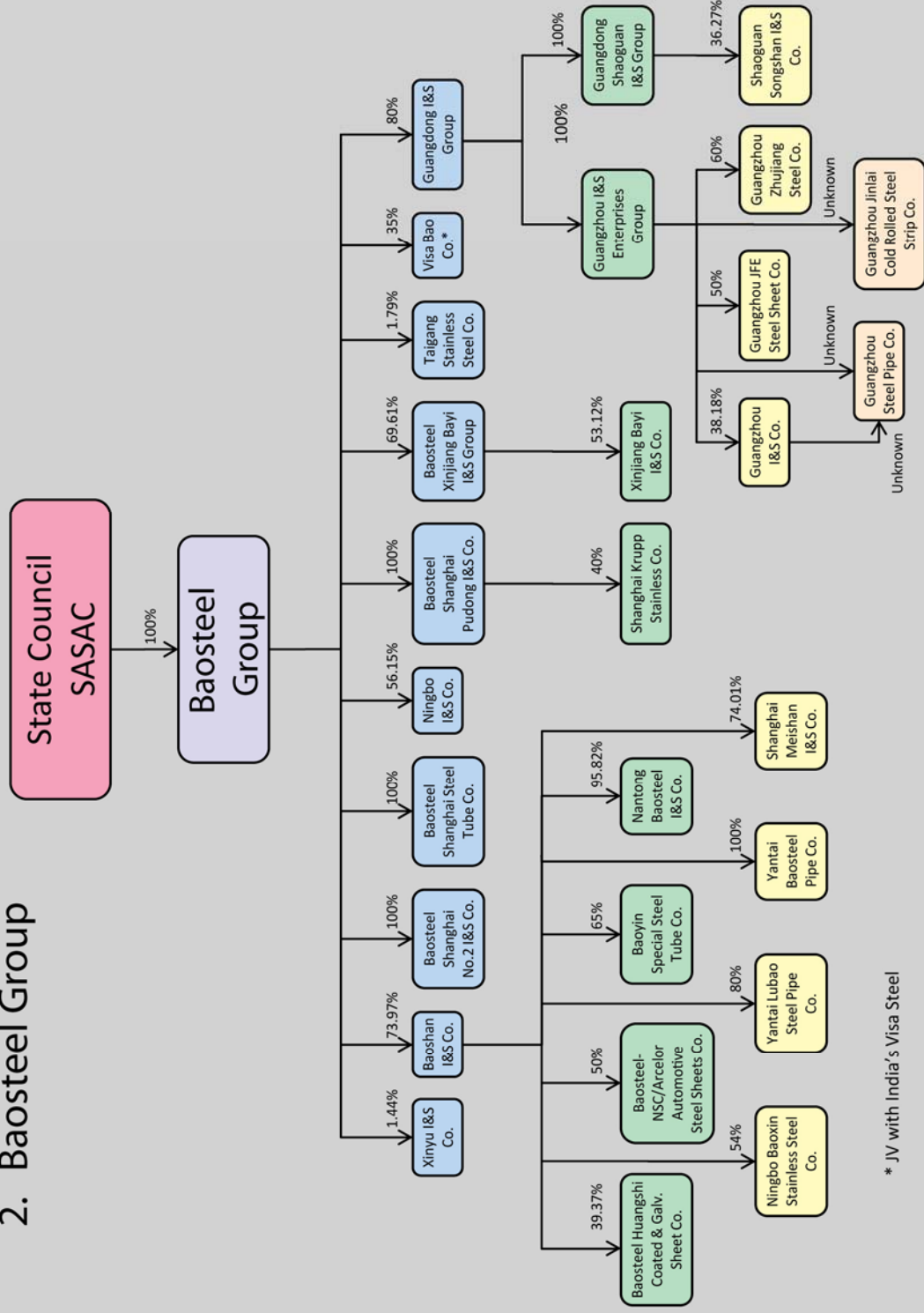

3. Wuhan Iron & Steel Group

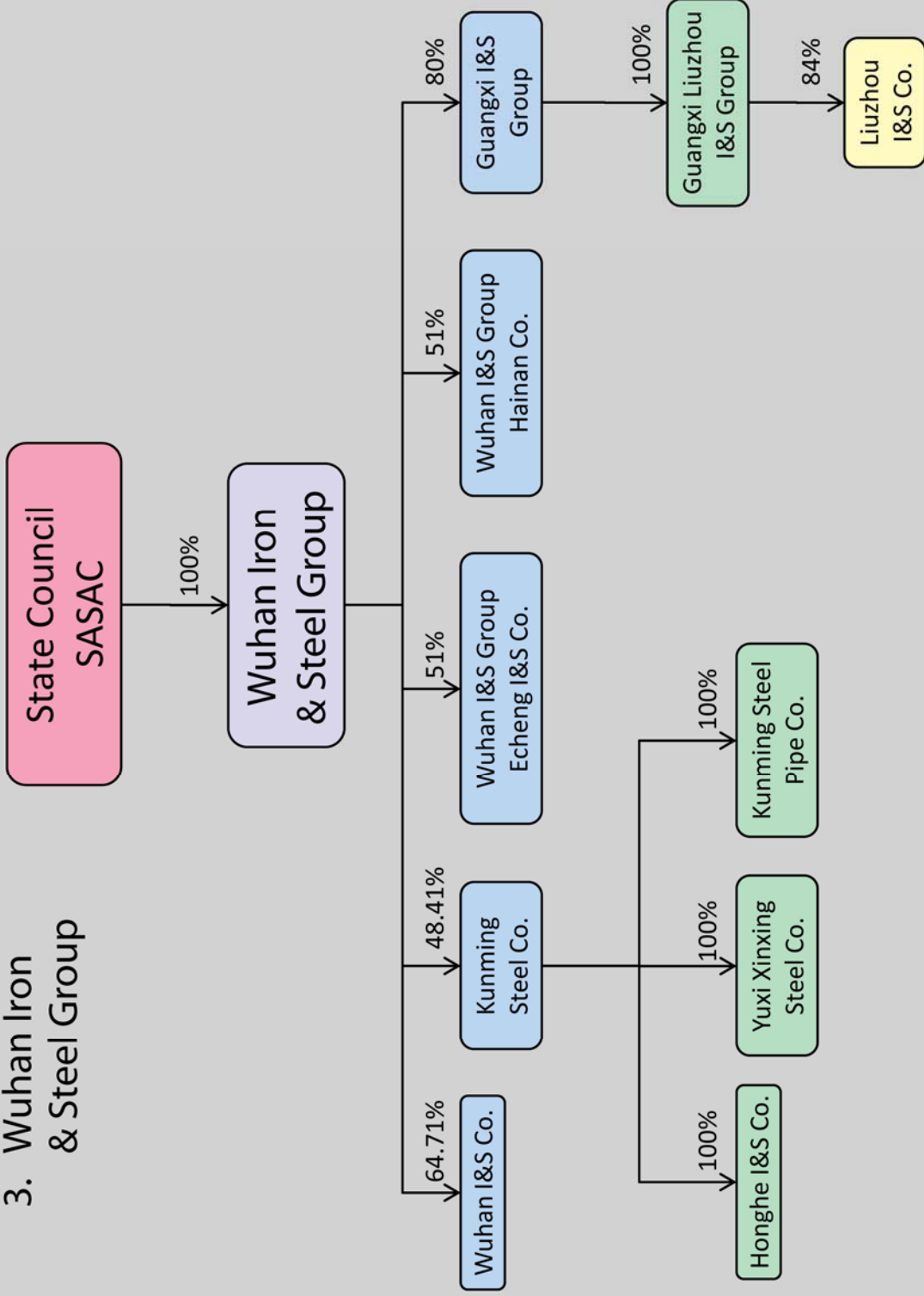

4. Anben Iron & Steel Group

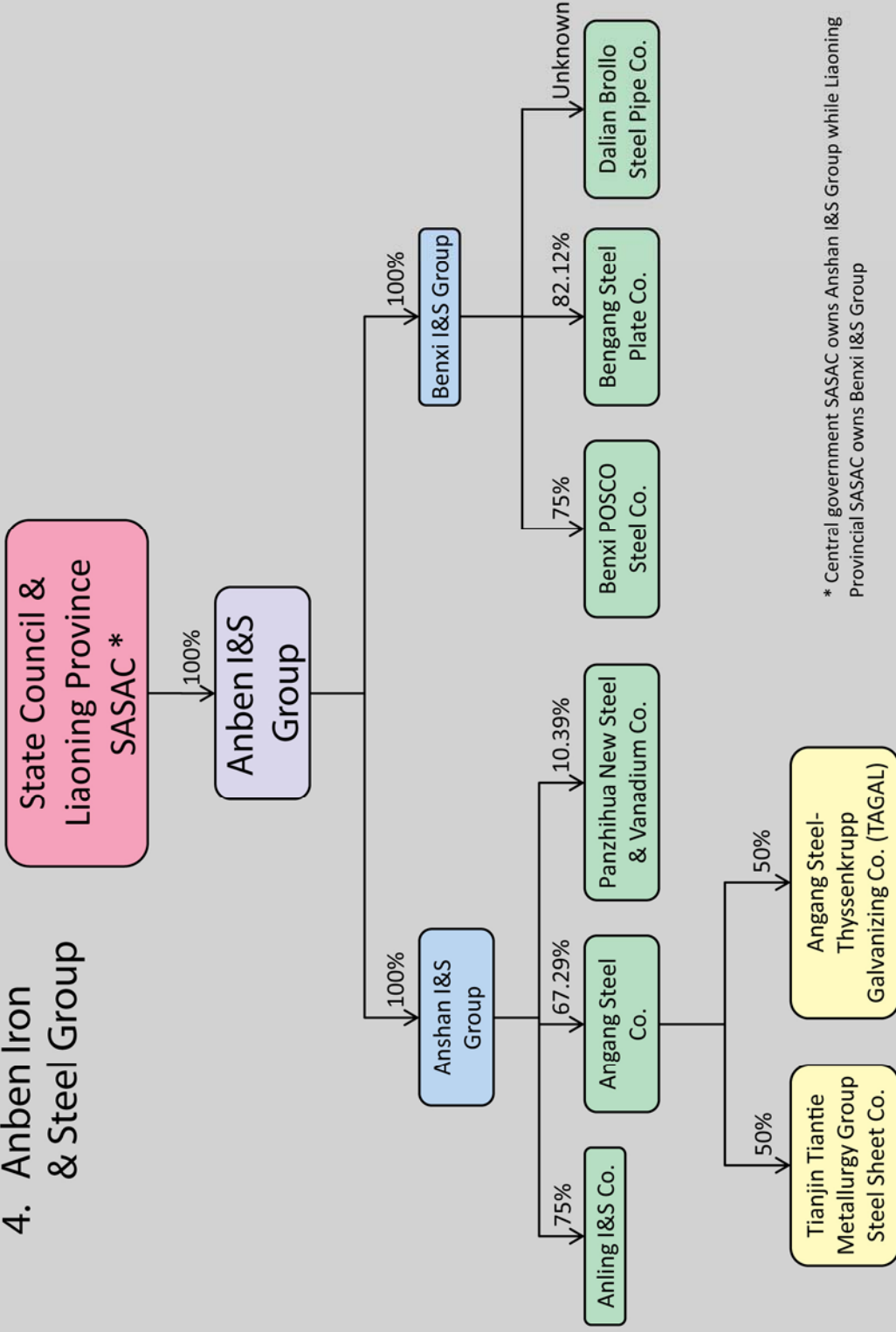

* Central government SASAC owns Anshan I&S Group while Liaoning Provincial SASAC owns Benxi I&S Group